

Product Data Sheet

PS-00400, Rev. E
August 2007

Micro Motion® Series 1000 and 2000 Transmitters with MVD™ Technology

Micro Motion® Series 1000 and 2000 transmitters with MVD™ technology deliver powerful features that make managing your process easier.



2400S Compact integral transmitter

1700
2700 Versatile field-mount transmitter

1500
2500 Compact control-room transmitter

3300
3350 Frequency-input discrete controller

3500
3700 Integrated control and measurement platform

Advanced architecture with flexible installation options

- Integral or remote mounting provides maximum flexibility
- Cost-effective 4-wire interface reduces installation costs
- DIN rail option reduces complexity and increases versatility

Wide variety of I/O and application capabilities to fit your needs

- High-speed DSP for accuracy under the toughest conditions—entrained gas, high noise, high turndown, and more
- Concentration and net flow measurement eliminates the need for additional instruments
- Approved for custody transfer and certified for SIL2 and SIL3, which provides measurement confidence and reliability



Micro Motion Series 1000 and 2000 transmitters

Micro Motion transmitters and controllers utilize MVD technology to deliver accurate, high-speed multivariable signals. Micro Motion transmitters are available with a wide selection of communication protocols, including 4–20 mA, HART®, FOUNDATION fieldbus™, PROFIBUS, Modbus®, and more. That means you will always be able to receive the process information you need in a format that works for your installation. Micro Motion transmitters also carry advanced diagnostic tools, allowing you to rest easy knowing your process is being monitored correctly.

MVD technology. MVD technology makes your Micro Motion meter work smarter. Front-end digital processing dramatically reduces signal noise and gives you faster response time compared to analog devices.

Only MVD technology allows you to:

- Measure multiple variables
- Install easily with a standard 4-wire signal cable
- Identify and resolve problems easily with built-in smart diagnostics
- Choose transmitter capabilities based on your application's needs
- Upgrade transmitter functionality as needed

Series 1000 and 2000 transmitters with MVD technology. Series 1000 and 2000 transmitters allow you to choose the functionality you want. Series 1000 transmitters are perfect for applications that require single variable measurement. For more demanding applications, Series 2000 transmitters measure multiple variables simultaneously, have additional output and digital communications options, and can be used in custody transfer applications.

All Series 1000 and 2000 transmitters feature a cost-effective, hassle-free, 4-wire remote mounting to a Micro Motion Coriolis meter. Model 1700 and 2700 transmitters can also be integrally mounted on select Micro Motion meters. Series 1000 and 2000 transmitters are simple to start up with virtually no special programming requirements. When combined with an enhanced core processor, Series 1000 and 2000 transmitters can offer one-of-a-kind diagnostics such as in-situ meter verification, which verifies the integrity of both the sensor and the transmitter

Contents

Overview	3	Configurable I/O options	13
Applications	4	FOUNDATION fieldbus options	14
Electrical connections	5	Liquid flow performance	15
Input/output signals	6	Density performance (liquid only)	15
Digital communications	9	Gas flow performance	16
Power supply	10	Model 1700/2700 physical specifications	16
Environmental limits	10	Model 1500/2500 physical specifications	23
Environmental effects	11	Ordering information	25
Hazardous area classifications	11		

Overview

Model 1700

- For applications requiring only mass flow or volume flow measurement
 - Milliamp and a frequency/pulse output
 - HART or Modbus digital communications
 - Outputs one of: mass flow rate, volume flow rate, or gas standard volume flow rate
 - Compact, integral mounting to sensor with 360 degrees of rotation, or remote-mount option to a 4-wire or 9-wire Micro Motion sensor
 - Class I, Division 1/Zone 1 local operator interface
 - View process variables, handle alarms, control totalizers, meter configuration, and more
 - Interface functions can be customized and password protected
 - Supports English, French, Spanish, and German languages
 - TÜV-certified SIS certification
 - Available on the primary milliamp output with output option codes A, B, C, or D (see pages 27–29)
 - One meter can be used in SIL 2 applications, and SIL 3 levels can be achieved if redundant meters are used
 - 20 Hz / 100 Hz selectable response time
-

Model 2700

- For applications requiring simultaneous monitoring of multiple flow variables
 - Selected combinations of outputs including milliamp, frequency, and discrete I/O
 - Modbus, HART, FOUNDATION fieldbus, and PROFIBUS-PA digital communications
 - Simultaneously outputs multiple variables, including: mass flow rate, volume flow rate, gas standard volume flow rate, density, temperature, and drive gain
 - Compact, integral mounting to sensor with 360 degrees of rotation, or remote-mount option to a 4-wire or 9-wire Micro Motion sensor
 - Class I, Division 1/Zone 1 local operator interface
 - View process variables, handle alarms, control totalizers, meter configuration, and more
 - Interface functions can be customized and password protected
 - Supports English, French, Spanish, and German languages
 - TÜV-certified SIS certification
 - Available on the primary milliamp output with output option codes A, B, C, or D (see pages 27–29)
 - One meter can be used in SIL 2 applications, and SIL 3 levels can be achieved if redundant meters are used
 - 20 Hz / 100 Hz selectable response time
-

Model 1500

- For applications requiring only mass flow or volume flow measurement
 - Milliamp and a frequency/pulse output
 - HART or Modbus digital communications
 - Outputs one of: mass flow rate, volume flow rate, or gas standard volume flow rate
 - Compact, small-footprint, remote-mount transmitter using 35 mm DIN rail
 - Low power requirement with no need to run separate AC power to the sensor
 - 20 Hz / 100 Hz selectable response time
-

Model 2500

- For applications requiring simultaneous monitoring of multiple flow variables
 - Selected combinations of outputs including milliamp, frequency, and discrete I/O
 - HART or Modbus digital communications
 - Simultaneously outputs multiple variables, including: mass flow rate, volume flow rate, gas standard volume flow rate, density, temperature, and drive gain
 - Compact, small-footprint, remote-mount transmitter using 35 mm DIN rail
 - Low power requirement with no need to run separate AC power to the sensor
 - 20 Hz / 100 Hz selectable response time
-

Applications

Meter verification	Provides <i>in-situ</i> assessment of a Micro Motion Coriolis meter, determining whether the meter has been affected by erosion, corrosion, or other influences affecting meter calibration. No secondary references are required to perform this operation.
Discrete batch control	<ul style="list-style-type: none">• Easily configured simple batch control• For transmitters with analog or intrinsically safe outputs, the frequency output can be configured as a discrete output• For transmitters with configurable I/O, a channel can be configured as a discrete output
Custody transfer	<ul style="list-style-type: none">• Physical and software security• Security-alarm posting• Mass or volume totalizer that can be configured by the user• Custom formatting of receipt tickets• Audit trail of configuration changes
Petroleum measurement (API)	Provides API process variables, such as API volume flow and API average density.

Electrical connections

Input/output connections

Model 1700/2700	Two (Model 1700) or three (Model 2700) pairs of wiring terminals for transmitter outputs Screw terminals accept one or two solid conductors, 14 to 12 AWG (2.5 to 4.0 mm ²); or one or two stranded conductors, 22 to 14 AWG (0.34 to 2.5 mm ²)
Model 1500/2500	Three pairs of wiring terminals for transmitter outputs One pair of terminals for digital communications (Modbus/RS-485) Plug connectors accept stranded or solid conductors, 24 to 12 AWG (0.20 to 3.5 mm ²)

Power connection

Model 1700/2700	One pair of wiring terminals accepts AC or DC power One internal ground lug for power-supply ground wiring Screw terminals accept one or two solid conductors, 14 to 12 AWG (2.5 to 4.0 mm ²); or one or two stranded conductors, 22 to 14 AWG (0.34 to 2.5 mm ²)
Model 1500/2500	The transmitter has two pairs of terminals for the power connection: <ul style="list-style-type: none">• Either pair accepts DC power• The remaining pair is used for making a jumper connection to a second transmitter Plug connectors accept stranded or solid conductors, 24 to 12 AWG (0.20 to 2.5 mm ²)

Service port connection

Model 1700/2700	Two clips for temporary connection to the service port
Model 1500/2500	One pair of terminals supports Modbus/RS-485 signal or service port mode. On device power-up, user has 10 seconds to connect in service port mode. After 10 seconds, the terminals default to Modbus/RS-485 mode.

Core processor connection⁽¹⁾

The transmitter has two pairs of terminals for the 4-wire connection to the core processor:

- One pair is used for the RS-485 connection to the core processor
- One pair is used to supply power to the core processor

Plug connectors accept stranded or solid conductors, 24 to 12 AWG (0.20 to 2.5 mm²)

(1) For Model 1700/2700 transmitters with an integral core processor (mounting code C), the 4-wire connection between the transmitter and core processor is not normally accessed.

Input/output signals

All output options

Mounting codes R and B	One 4-wire sensor signal input connection, intrinsically safe
Mounting code C (9-wire remote transmitter)	One 9-wire sensor signal input connection, intrinsically safe

Output option code A: Non-intrinsically safe analog output (with HART and Modbus) Models 1500, 1700, and 2700 transmitters

One active 4–20 mA output	<p>Not intrinsically safe</p> <p>Isolated to ± 50 VDC from all other outputs and earth ground</p> <p>Maximum load limit: 820 ohms</p> <p>Models 1500 and 1700 can report mass flow or volume flow</p> <p>Model 2700 can report mass flow, volume flow, density, temperature, or drive gain</p> <p>Output is linear with process from 3.8 to 20.5 mA, per NAMUR NE43 (June 1994)</p>
One active frequency/pulse output ⁽¹⁾	<p>Not intrinsically safe</p> <p>Can report mass flow or volume flow, which can be used to indicate flow rate or total</p> <p>For Models 1500 and 1700, frequency output reports the same flow variable as the mA output</p> <p>For Model 2700, frequency output is independent of mA output</p> <p>Scalable to 10,000 Hz</p> <p>For Model 1500, output voltage is +15 VDC $\pm 3\%$ with a 2.2 kohm internal pull-up resistor</p> <p>For Models 1700/2700, output voltage is +24 VDC $\pm 3\%$ with a 2.2 kohm internal pull-up resistor</p> <p>Output is linear with flow rate to 12,500 Hz</p> <p>Configurable polarity: active high or active low</p> <p>Model 2700 discrete output: Can report five discrete events, flow direction, flow switch, calibration in progress, or fault</p> <p>Maximum sink capability is 500 mA</p>

(1) On Model 2700 transmitters, this can also be configured as a discrete output.

Input/output signals *continued*

Output option codes B and C: Non-intrinsically safe configurable output Models 2500 and 2700 transmitters

Transmitter has a total of 3 configurable inputs/outputs. Refer to the data below and the information on page 13 for the ways that these 3 inputs/outputs can be configured.

One or two active 4–20 mA outputs	<p>Not intrinsically safe</p> <p>Isolated to ± 50 VDC from all other outputs and earth ground</p> <p>Maximum load limit of mA1: 820 ohms; of mA2: 420 ohms</p> <p>Can report mass flow, volume flow, density, temperature, or drive gain</p> <p>Output is linear with process from 3.8 to 20.5 mA, per NAMUR NE43 (June 1994)</p>
One or two active or passive frequency/pulse output	<p>Not intrinsically safe</p> <p>Can report mass flow or volume flow, which can be used to indicate flow rate or total</p> <p>If configured as a dual pulse output, the channels are electrically isolated but not independent (see custody transfer note below)</p> <p>Scalable to 10,000 Hz</p> <p>If internally powered (active), output voltage is +15 VDC $\pm 3\%$ with a 2.2 kohm internal pull-up resistor.</p> <p>If externally powered (passive), output voltage is 30 VDC maximum, 24 VDC typical, sinking up to 500 mA at 30 VDC.</p> <p>Output is linear with flow rate to 12,500 Hz</p>
One or two active or passive discrete outputs	<p>Not intrinsically safe</p> <p>Can report five discrete events, flow switch, forward/reverse flow, calibration in progress, or fault</p> <p>If internally powered (active), output voltage is +15 VDC $\pm 3\%$ with a 2.2 kohm internal pull-up resistor.</p> <p>If externally powered (passive), output voltage is 30 VDC maximum, 24 VDC typical, sinking up to 500 mA at 30 VDC.</p>
One discrete input	<p>Can be configured for internal or external power</p> <p>Not intrinsically safe</p> <p>Internal power +15 VDC, 7 mA maximum source current</p> <p>External power +3–30 VDC maximum</p> <p>Can start/stop totals and inventories, reset all totals, reset mass total, reset volume total, start sensor zero, or initiate multiple actions</p>
Custody transfer using double pulse frequency output	<p>The transmitter can be configured for two frequency outputs. The second output can be phase-shifted 0, 90, or 180 degrees from the first output, or the dual-pulse output can be set to quadrature mode.</p>

Output option codes E and G: FOUNDATION fieldbus and PROFIBUS-PA Model 2700 transmitters

One FOUNDATION fieldbus H1 or PROFIBUS-PA output	<p>FOUNDATION fieldbus and PROFIBUS-PA wiring is intrinsically safe with an intrinsically safe power supply</p> <p>The transmitter fieldbus circuit is passive, and draws power from the fieldbus segment. Current draw from the fieldbus segment is 11.5 mA.</p> <p>Manchester-encoded digital signal conforms to IEC 61158-2</p>
--	--

Input/output signals *continued*

Output option code D: Intrinsically safe Model 1700 and 2700 transmitters

One intrinsically safe passive 4–20mA output (two with Model 2700)

Maximum input voltage, 30 VDC, 1 watt maximum

Maximum current 300 mA

Maximum load limits, see chart below

Model 1700 can report mass flow or volume flow; Model 2700 can report mass flow, volume flow, density, temperature, or drive gain

Entity parameters: $U_i = 30$ VDC, $I_i = 300$ mA, $P_i = 1$ W, $C_i =$ negligible, $L_i =$ negligible

Output is linear with process from 3.8 to 20.5 mA, per NAMUR NE43 (June 1994)

mA Output Load Resistance Value
 $R_{max} = (V_{supply} - 12)/0.023^*$
 *If communicating with HART a minimum of 250 ohms and 17.75 V supply is needed

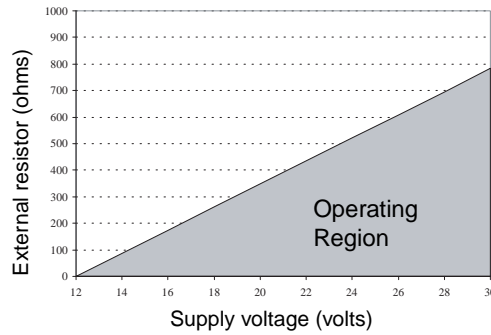

One intrinsically safe frequency/pulse output (Model 1700) or configurable frequency/pulse/discrete output (Model 2700)

Maximum input voltage, 30 VDC, 0.75 watt maximum

Maximum current 100 mA

Maximum load limit, see chart below

Can report mass flow or volume flow, which can be used to indicate flow rate or total

For Model 1700, frequency output reports the same flow variable as the mA output

For Model 2700, frequency output is independent of the mA output

Scalable to 10,000 Hz

Entity parameters: $U_i = 30$ VDC, $I_i = 100$ mA, $P_i = 0.75$ W, $C_i =$ negligible, $L_i =$ negligible

Output is linear with flow rate to 12,500 Hz

Frequency Output Load Resistance Value

$$R_{max} = (V_{supply} - 4)/0.003$$

$$*R_{min} = (V_{supply} - 25)/0.006$$

*Absolute minimum = 100 ohms for $V_{supply} < 25.6$ volts

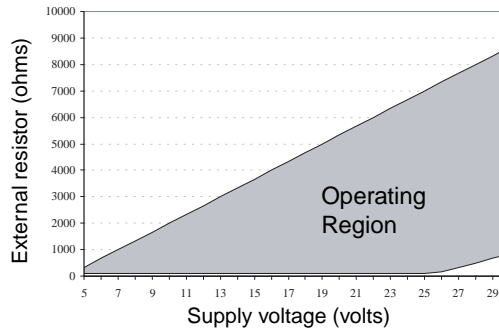

Digital communications

All output options

One service port can be used for temporary connection only
Uses RS-485 Modbus signal, 38.4 kilobaud, one stop bit, no parity

HART/Modbus

Models/output option codes:

- All models with output code A
- Model 2500 with output codes B and C

One RS-485 output can be used for direct connection to a HART or Modbus host system.
Accepts data rates between 1200 baud and 38.4 kilobaud.

HART Bell 202

Models/output option codes:

- Models 1700, 2500, and 2700 with output codes A, B, C, and D

HART Bell 202 signal is superimposed on the primary milliamp output, and is available for host system interface.

- Frequency 1.2 and 2.2 kHz
- Amplitude: to 1.0 mA
- 1200 baud
- Requires 250 to 600 ohms load resistance

FOUNDATION fieldbus

Models/output option codes:

- Model 2700 with output code E

Transmitters are registered with the Fieldbus Foundation, and conform to the FOUNDATION fieldbus H1 protocol specification.

FISCO Field device in compliance with TS-60079-27:2002
U_i = 30 V, I_i = 380 mA, P_i = 5.32 W,
C_i = negligible, L_i = negligible

PROFIBUS-PA

Models/output option codes:

- Model 2700 with output code G

Transmitters are registered with the Profibus Organization, and fulfill the requirements of the PROFIBUS-PA Profile for Process Control Devices. Siemens® Simatic® PDM is required for configuration.

FISCO Field device in compliance with TS-60079-27:2002
U_i = 30 V, I_i = 380 mA, P_i = 5.32 W,
C_i = negligible, L_i = negligible

Power supply

Model 1700/2700

Self-switching AC/DC input, automatically recognizes supply voltage. Complies with low voltage directive 73/23/EEC per IEC 1010-1 with amendment 2. Installation (Overvoltage) Category II, Pollution Degree 2.

AC power	85 to 265 VAC, 50/60 Hz, 6 watts typical, 11 watts maximum.
DC power	18 to 100 VDC, 6 watts typical, 11 watts maximum Minimum 22 VDC with 1000 feet of 18 AWG (300 meters of 0.8 mm ²) power-supply cable. At startup, transmitter power source must provide a minimum of 1.5 amperes of short-term current at a minimum of 18 volts at the transmitter's power input terminals.
Fuse	IEC 127-1.25 fuse, slowblow.

Model 1500/2500

Transmitter power supply meets Installation (Overvoltage) Category II, Pollution Degree 2 requirements.

DC power	Minimum 19.2 to 28.8 VDC, 6.3 watts At startup, transmitter power source must provide a minimum of 1.0 amperes of short-term current per transmitter. Length and conductor diameter of the power cable must be sized to provide 19.2 VDC minimum at the power terminals, at a load current of 330 mA.
Fuse	IEC 1.6A fuse, slowblow

Environmental limits

			°F	°C
Ambient temperature limits	Model 1700/2700 ⁽¹⁾⁽²⁾	Operating	-40 to +140	-40 to +60
		Storage	-40 to +140	-40 to +60
	Model 1500/2500 ⁽³⁾	Operating	-40 to +131	-40 to +55
		Storage	-40 to +185	-40 to +85
Humidity limits	5 to 95% relative humidity, non-condensing at 140 °F (60 °C)			
Vibration limits	Meets IEC 68.2.6, endurance sweep, 5 to 2000 Hz, 50 sweep cycles at 1.0 g			

(1) Display responsiveness decreases, and display may become difficult to read, below -4 °F (-20 °C). Above 131 °F (55 °C), some darkening of display might occur.

(2) ATEX and UL approvals require limiting ambient temperature to below 131 °F (55 °C).

(3) If the temperature is above 131 °F (55 °C), and you are mounting multiple transmitters, the transmitters must be at least 8.5 mm apart.

Environmental effects

EMI effects	Complies with NAMUR NE21 (August 1998 German and May 1999 English). Meets EMC directive 89/336/EEC per EN 50081-2 (August 1993), EN 50082-2 (March 1995), and EN 61326 Industrial.
Ambient temperature effect	On analog outputs $\pm 0.005\%$ of span per °C

Hazardous area classifications — Model 1700/2700



UL, CSA, and CSA C-US

Ambient temperature is limited to below 131 °F (55 °C) for UL and CSA compliance.

Transmitter	Class I, Div. 1, Groups C and D. Class II, Div. 1, Groups E, F, and G explosion proof (when installed with approved conduit seals). Otherwise, Class I, Div. 2, Groups A, B, C, and D.
Outputs	Provides nonincendive sensor outputs for use in Class I, Div. 2, Groups A, B, C, and D; or intrinsically safe sensor outputs for use in Class I, Div. 1, Groups C and D or Class II, Div. 1, Groups E, F, and G.

ATEX

Ambient temperature is limited to below 131 °F (55 °C) for ATEX compliance.

Analog outputs (with HART/Modbus) and configurable input/output transmitters (output option codes A, B, or C)	All models CE 0575 	II 2G		
		II 2D Ex tD A21 IP66/IP67 T65 °C		
	Flameproof (when installed with approved cable glands):	With display	Ex d [ib] IIB+H ₂ T5	
		Without display	Ex d [ib] IIC T5	
	Increased safety (when installed with approved cable glands):	With display	Ex de [ib] IIB+H ₂ T5	
		Without display	Ex de [ib] IIC T5	
FOUNDATION fieldbus, PROFIBUS-PA, and IS output transmitters (output option codes D, E, and G)	All models CE 0575 	II 2(1)G		
		II 2D Ex tD A21 IP66/IP67 T65 °C		
	Output codes E and G are FISCO field devices in compliance with TS-60079-27:2002			
	Flameproof (when installed with approved cable glands):	With display	Ex d [ia/ib] IIB+H ₂ T5	
		Without display	Ex d [ia/ib] IIC T5	
	Increased safety (when installed with approved cable glands):	With display	Ex de [ia/ib] IIB+H ₂ T5	
Without display		Ex de [ia/ib] IIC T5		

Hazardous area classifications — Model 1700/2700 *continued*

IECEX

Ambient temperature is limited to below 131 °F (55 °C) for IECEx compliance.

HART/Modbus and configurable input/output transmitters (output option codes A, B, or C)	Flameproof when installed with approved cable glands	With display	Ex d [ib] IIB+H ₂ T5
		Without display	Ex d [ib] IIC T5
FOUNDATION fieldbus, PROFIBUS-PA, and IS output transmitters (output option codes D, E, and G)	Flameproof when installed with approved cable glands	With display	Ex d [ib] IIB+H ₂ T5
		Without display	Ex d [ib] IIC T5

NEPSI

HART/Modbus and configurable input/output transmitters (output option codes A, B, or C)	Flameproof	With display	Ex d [ib] IIB+H ₂ T5
		Without display	Ex d [ib] IIC T5
	Increased safety	With display	Ex de [ib] IIB+H ₂ T5
		Without display	Ex de [ib] IIC T5
FOUNDATION fieldbus, PROFIBUS-PA, and IS output transmitters (output option codes D, E, and G)	Flameproof	With display	Ex d [ia/ib] IIB+H ₂ T5
		Without display	Ex d [ia/ib] IIC T5
	Increased safety	With display	Ex de [ia/ib] IIB+H ₂ T5
		Without display	Ex de [ia/ib] IIC T5

Hazardous area classifications — Model 1500/2500

CSA and CSA C-US

Transmitter ⁽¹⁾	Class I, Div. 2, Groups A, B, C, and D
Sensor and sensor wiring to transmitter	Class I, Div. 1, Groups C and D or Class II, Div. 1, Groups E, F, and G

ATEX

Ambient temperature is limited to -40 to +131 °F (-40 to +55 °C) for ATEX compliance.

All models CE 0575  II(2) G [EEx ib] IIB/IIC

(1) The Model 1500/2500 transmitter is a component only and must be installed in a suitable enclosure.

Series 2000 transmitters with configurable inputs and outputs

Series 2000 transmitters with configurable I/O functionality

The Series 2000 transmitter with configurable inputs and outputs is designed to increase transmitter flexibility and reduce the number of transmitter variations required in inventory. The table below shows the various configuration options that can be produced with the configurable I/O output option.

Channel assignments for Series 2000 transmitters with configurable I/O (output option codes B and C)

- When output code B is selected, the transmitter ships with channels assigned to default values.
- When output code C is selected, the transmitter is custom configured prior to shipment.

Channel	Terminals		Configuration options	Default variable assignment	Power
	2700	2500			
A	1 & 2	21 & 22	mA output with Bell 202/HART (only)	Mass flow	Internal
B	3 & 4	23 & 24	mA output (default)	Density	Internal
			Frequency output ⁽¹⁾	Mass flow	Internal or external ⁽²⁾
			Discrete output	Fwd/rev flow	Internal or external
C	5 & 6	31 & 32	Frequency output (default) ⁽¹⁾	Mass flow	Internal or external
			Discrete output	Flow switch	Internal or external
			Discrete input	None	Internal or external

(1) If channels B and C are both configured as a frequency output (dual pulse), both outputs are generated from the same signal. The outputs are electrically isolated but not independent.

(2) The user must supply power when a channel is set to external power.

Model 2700 transmitter with FOUNDATION fieldbus

Fieldbus software functionality	Model 2700 FOUNDATION fieldbus software is designed to permit remote testing and configuration of the transmitter using the DeltaV™ Fieldbus Configuration Tool, or other FOUNDATION fieldbus compliant hosts. The Coriolis sensor signal is channelled through the flowmeter to the control room and the FOUNDATION fieldbus configuration device.
Transducer blocks	<p>Transducer blocks hold data from the Coriolis sensor, including process variables, configuration, calibration, and diagnostics.</p> <p>The Model 2700 transmitter with FOUNDATION fieldbus provides up to seven transducer blocks:</p> <ul style="list-style-type: none">• Measurement For process variables• Calibration For calibration information• Diagnostic For diagnosing problems and running diagnostic tests (including the new in-situ meter verification procedure, if the transmitter is paired with an enhanced core processor)• Device Information For data such as sensor type• Local Display For configuring the transmitter display• API For petroleum measurement calculations using API MPMS Chapter 11.1• Enhanced Density For complex density and concentration calculations (e.g., %HFCS, SG60/60)
Resource block	The resource block contains physical device information, including available memory, manufacturer identification, type of device, and features.
Analog input function blocks	The Analog Input (AI) function block processes the measurement from the Coriolis sensor and makes it available to other function blocks. It also allows filtering, alarm handling, and engineering unit changes. Each of the four Model 2700 AI blocks can be assigned to one of 20 available variables.
Analog output block	The AO function block assigns an output value to a field device through a specified channel. The block supports mode control, signal status calculation, and simulation. The AO block can report either pressure from an external pressure source or temperature from an external temperature source.
Proportional integral derivative block	The optional proportional integral derivative (PID) function block combines all the necessary logic to perform proportional/integral/derivative control. The block supports mode control, signal scaling and limiting, feed forward control, override tracking, alarm limit detection, and signal status propagation.
Integrator block	The integrator block provides functionality for the transmitter totalizers. The flow variable (mass or volume) can be selected and reset.
Diagnostics and service	<p>Model 2700 transmitters automatically perform continuous self diagnostics. Using the Diagnostic transducer block, the user can perform on-line testing of the transmitter and sensor. Diagnostics are event driven and do not require polling for access.</p> <p>The Model 2700 also supports meter fingerprinting, which allows you to capture device-level snapshots of your meter performance.</p>

Liquid flow performance

	Sensor model	
Mass flow accuracy⁽¹⁾⁽²⁾	ELITE®	±0.05% of rate
	F-Series	±0.10% of rate
	H-Series	±0.10% of rate
	T-Series	±0.15% of rate
	R-Series	±0.50% of rate
Volume flow accuracy⁽¹⁾⁽²⁾	ELITE	±0.05% of rate
	F-Series	±0.15% of rate
	H-Series	±0.15% of rate
	T-Series	±0.25% of rate
	R-Series	±0.50% of rate
Repeatability⁽²⁾	ELITE	±0.025% of rate
	F-Series	±0.05% of rate
	H-Series	±0.05% of rate
	T-Series	±0.05% of rate
	R-Series	±0.25% of rate

(1) Stated flow accuracy includes the combined effects of repeatability, linearity, and hysteresis.

(2) For the details of flow accuracy and repeatability specifications, refer to the product data sheet for each sensor family.

Density performance (liquid only)

	Sensor model	g/cm ³	kg/m ³
Accuracy⁽¹⁾	ELITE	±0.0002	±0.2
	F-Series	±0.001	±1.0
	H-Series	±0.001	±1.0
	T-Series	±0.002	±2.0
	R-Series	Not rated for density	
Repeatability⁽¹⁾	ELITE	±0.0001	±0.1
	F-Series	±0.0005	±0.5
	H-Series	±0.0005	±0.5
	T-Series	±0.0005	±0.5
	R-Series	Not rated for density	

(1) For the details of the density accuracy and repeatability specifications, refer to the product data sheet for each sensor family.

Gas flow performance

	Sensor model	
Accuracy	ELITE®	±0.35% of rate
	T-Series	±0.50% of rate
	F-Series	±0.50% of rate
	H-Series	±0.50% of rate
	R-Series	±0.75% of rate
Repeatability	ELITE	±0.20% of rate
	T-Series	±0.05% of rate
	F-Series	±0.25% of rate
	H-Series	±0.25% of rate
	R-Series	±0.5% of rate

Model 1700/2700 physical specifications

Housing	NEMA 4X (IP66) polyurethane-painted cast aluminum		
Weight⁽¹⁾	4-wire remote transmitter	With display	8 lb (3.6 kg)
		Without display	7 lb (3.2 kg)
	9-wire remote transmitter	With display	14 lb (6.3 kg)
		Without display	13 lb (5.9 kg)
Terminal compartments	Output terminals are physically separated from the power- and service-port terminals.		
Cable gland entrances	1/2"–14 NPT or M20 × 1.5 female conduit ports for outputs and power supply 3/4"–14 NPT female conduit port for sensor/core processor cable		
Mounting	Available integrally mounted to Micro Motion T-Series, R-Series, F-Series, and H-Series sensors May be remotely connected to any 4-wire or 9-wire Micro Motion sensor Remote-mount transmitters include a 304L stainless steel mounting bracket. Hardware for installing the transmitter on the mounting bracket is included. Transmitter can be rotated on the sensor or the mounting bracket, 360 degrees, in 90-degree increments		

(1) For weight of integrally mounted transmitter and sensor, refer to sensor product data sheet.

Model 1700/2700 physical specifications *continued*

	Cable type	Wire gauge	Maximum length
Maximum cable lengths between sensor and transmitter	Micro Motion 9-wire	Not applicable	60 feet (20 meters)
	Micro Motion 4-wire	Not applicable	1000 feet (300 meters)
	User-supplied 4-wire:		
	• Power wires (VDC)	22 AWG (0.34 mm ²)	300 feet (90 meters)
		20 AWG (0.5 mm ²)	500 feet (150 meters)
18 AWG (0.8 mm ²)		1000 feet (300 meters)	
• Signal wires (RS-485)	22 AWG (0.34 mm ²) or larger	1000 feet (300 meters)	
Interface/display	<p>Segmented 2-line display with LCD screen with optical controls and flowmeter-status LED is standard. Suitable for hazardous area installation.</p> <p>Available in both backlit and non-backlit versions</p> <p>To facilitate various mounting orientations, the display can be rotated on transmitter, 360 degrees, in 90-degree increments.</p> <p>LCD line 1 lists the process variable. LCD line 2 lists engineering unit of measure.</p> <p>Non-glare tempered glass lens.</p> <p>Display supports English, French, German, and Spanish languages.</p> <p>Display controls feature optical switches that are operated through the glass with a red LED for visual feedback to confirm when a “button” is pressed.</p>		
Display functions	Operational	View process variables; start, stop, and reset totalizers; view and acknowledge alarms.	
	Off-line	Zero flowmeter, meter verification, simulate outputs, change measurement units, configure outputs, and set RS-485 communications options.	
	Status LED	Three-color LED status light on display panel indicates flowmeter condition at a glance.	

Model 1700/2700 dimensions

Remote-mount transmitter with display

Dimensions in inches
(mm)

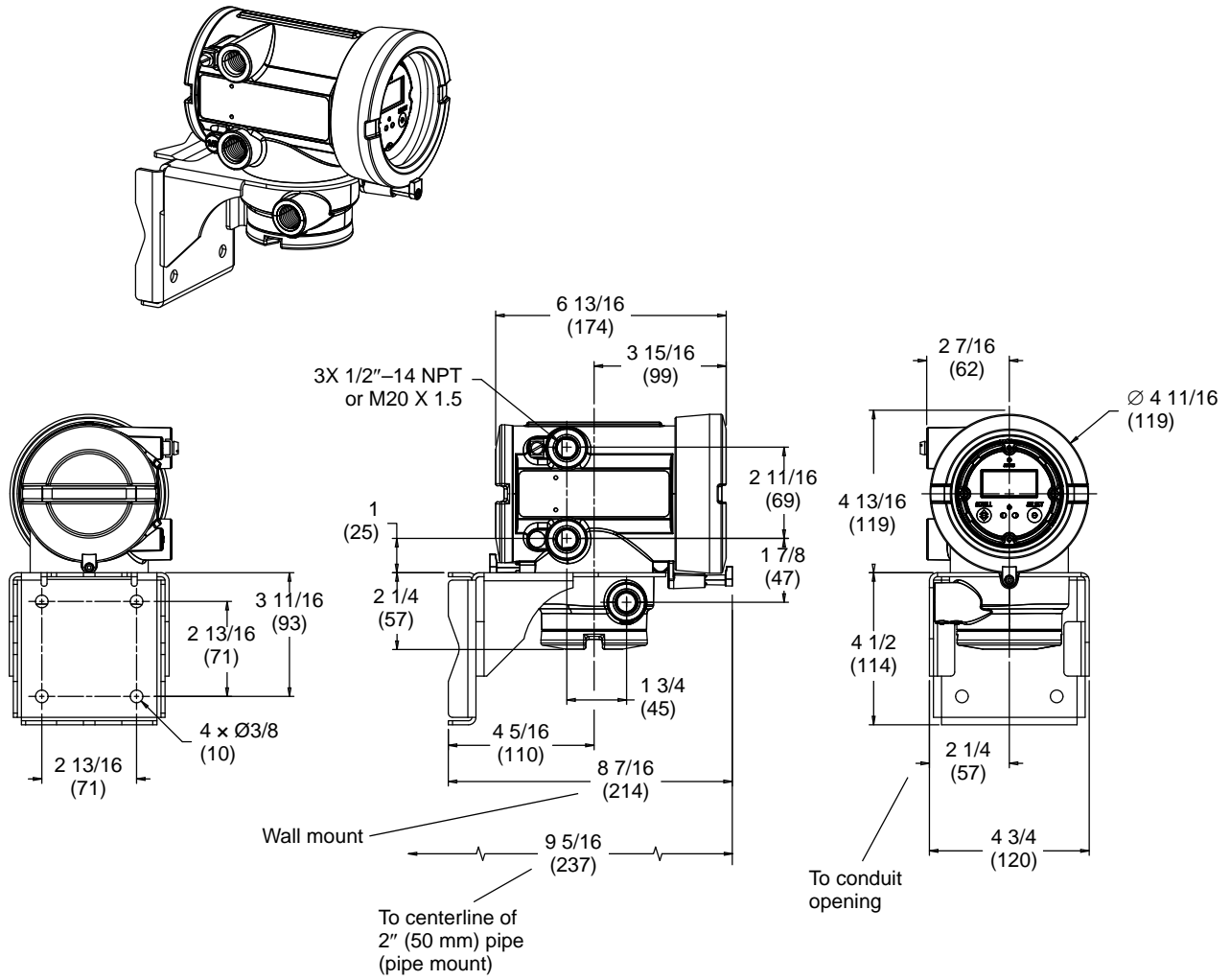

For dimensions of integrally mounted transmitter and sensor, refer to the sensor product data sheet.

Model 1700/2700 dimensions *continued*

Remote-mount transmitter without display

Dimensions in inches
(mm)

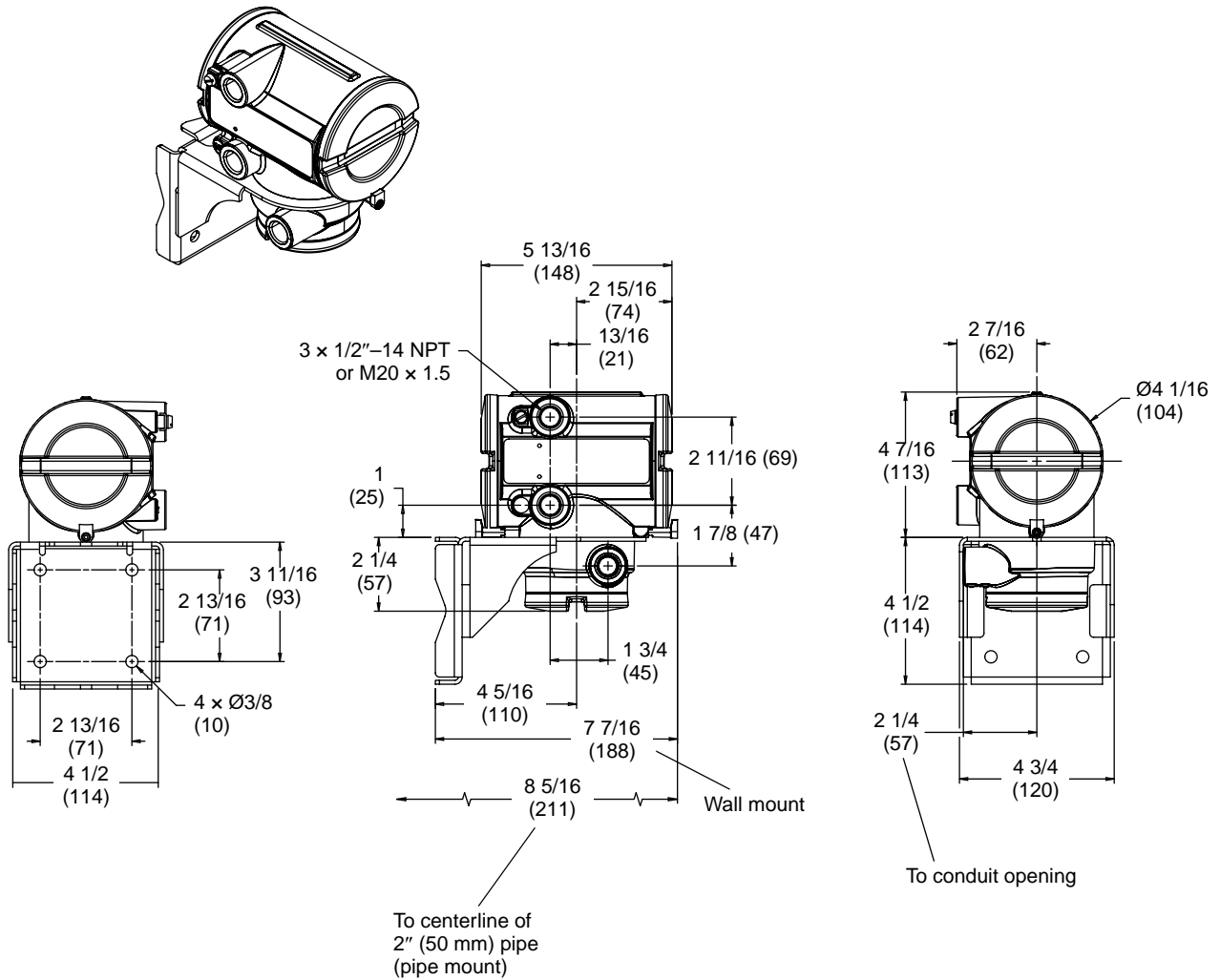

For dimensions of integrally mounted transmitter and sensor, refer to the sensor product data sheet.

Model 1700/2700 dimensions *continued*

Remote-mount transmitter/core processor assembly with display

Dimensions in inches
(mm)

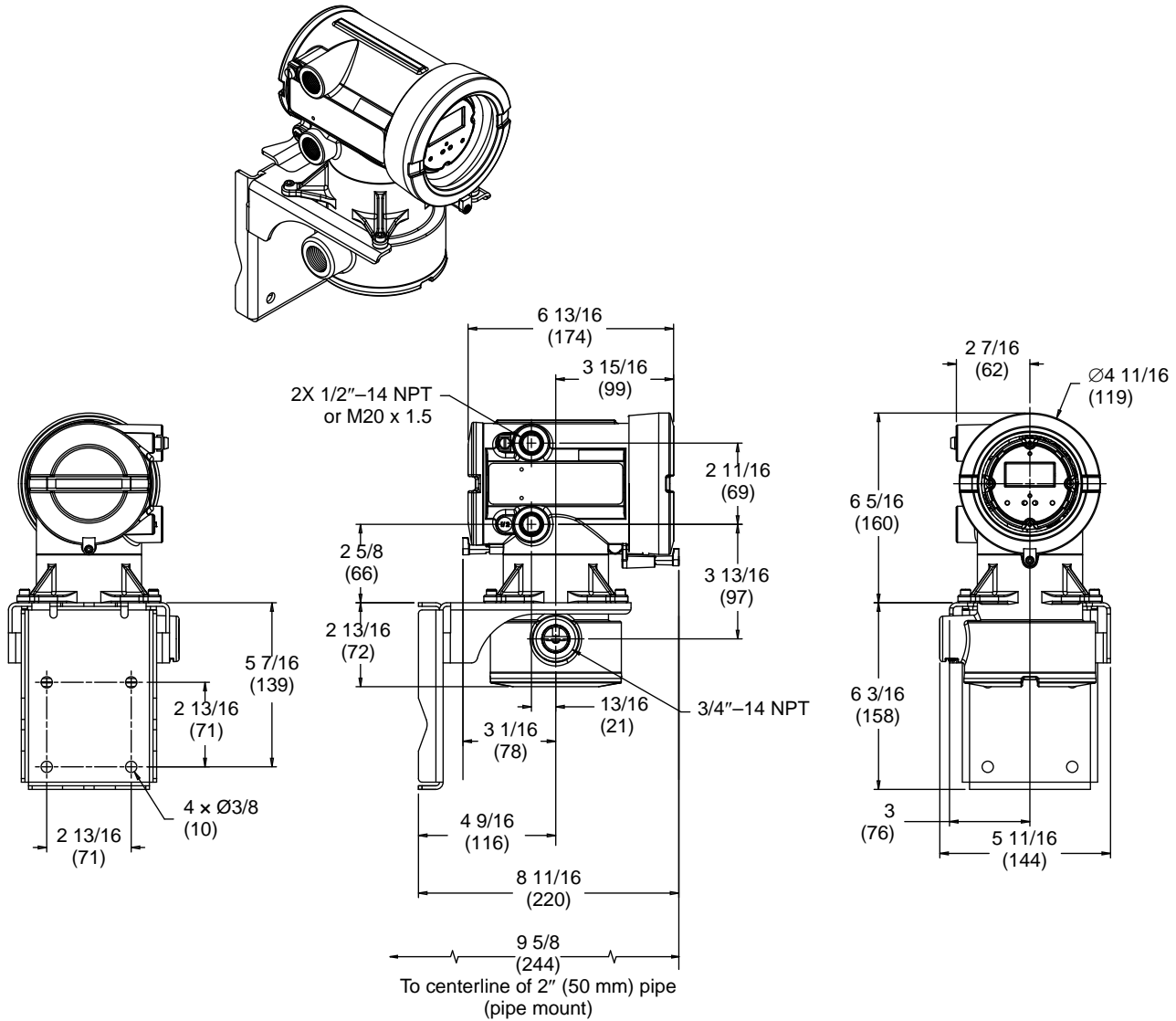

For dimensions of integrally mounted transmitter and sensor, refer to the sensor product data sheet.

Model 1700/2700 dimensions *continued*

Remote core processor

Dimensions in inches
(mm)

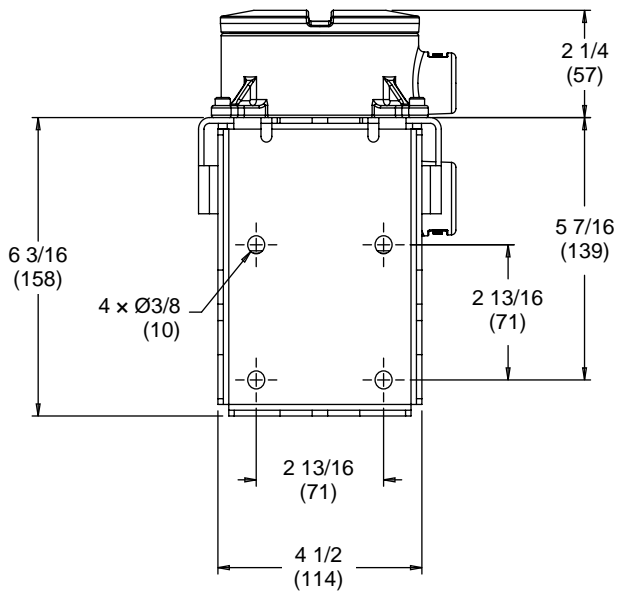
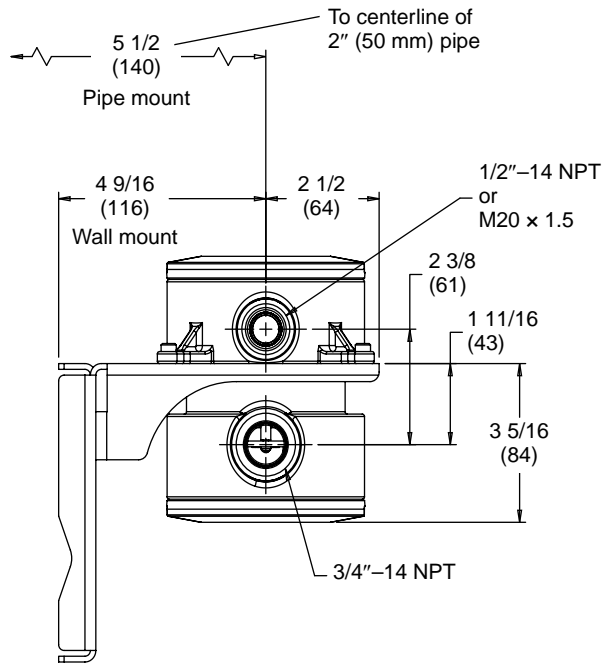
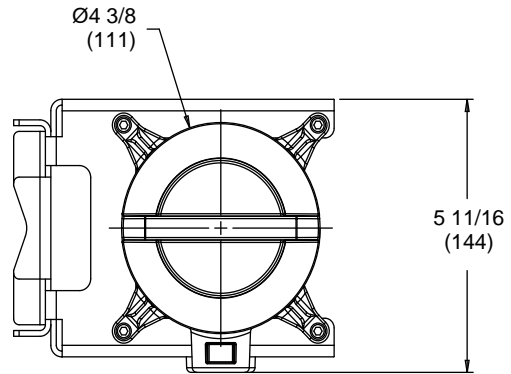
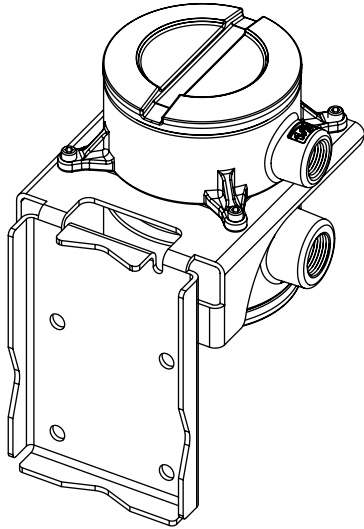

Model 1500/2500 physical specifications

Weight 0.52 lb (0.24 kg)

Mounting Mounted on 35 mm rail
 Rail must be grounded
 May be remotely connected to any Micro Motion sensor
 Requires standard 4-wire twisted, shielded signal cable, up to 1000 feet (300 meters) in length, between the sensor and the transmitter. (If the core processor is remotely mounted from the sensor, the maximum length of the 9-wire signal cable between the sensor and the remote core processor is 60 feet [20 meters].)

	Cable type	Wire gauge	Maximum length
Maximum cable lengths between sensor and transmitter	Micro Motion 9-wire	Not applicable	60 feet (20 meters)
	Micro Motion 4-wire	Not applicable	1000 feet (300 meters)
	User-supplied 4-wire:		
	• Power wires (VDC)	22 AWG (0.34 mm ²)	300 feet (90 meters)
		20 AWG (0.5 mm ²)	500 feet (150 meters)
18 AWG (0.8 mm ²)		1000 feet (300 meters)	
• Signal wires (RS-485)	22 AWG (0.34 mm ²) or larger	1000 feet (300 meters)	

Status LED Three-color status LED on face of transmitter indicates flowmeter condition at a glance, using a solid green, yellow, or red light. Zero in progress is indicated by a flashing yellow light.

Zero button A zero button on the face of the transmitter can be used to start the transmitter zero procedure.

Model 1500/2500 dimensions

Dimensions in inches
(mm)

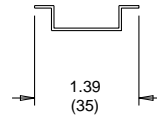
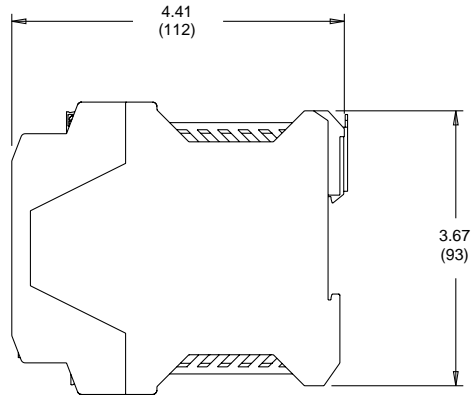
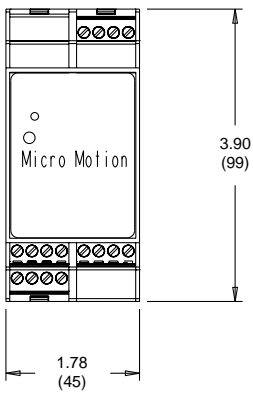
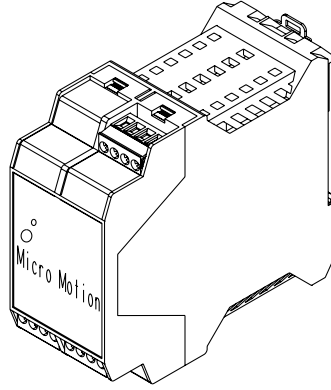
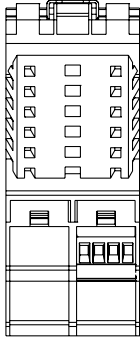

For mounting on a 35 mm rail

Ordering information — Model 1700

Model	Product description
1700	Micro Motion Coriolis MVD single variable flow transmitter
Code	Mounting
R	4-wire remote mount transmitter
I	Integral mount transmitter
B ⁽¹⁾	4-wire remote mount transmitter with 9-wire remote core processor (includes 10 ft. [3 m] CFEPS cable)
C	9-wire remote transmitter (requires sensor with junction box; includes 10 ft. [3 m] CFEPS cable)
Code	Power
1	18 to 100 VDC or 85 to 265 VAC; self switching
Code	Display
1	Dual line display for process variables and totalizer reset
2	Backlit dual line display for process variables and totalizer reset
3	No display
Code	Output options
A	Analog outputs: one mA; one frequency; RS485
D	Intrinsically safe analog outputs: one mA, one frequency
Code	Conduit connections
B	1/2-inch NPT — no gland
C ⁽¹⁾	1/2-inch NPT with brass/nickel cable gland
D ⁽¹⁾	1/2-inch NPT with stainless steel cable gland
E	M20 — no gland
F	M20 with brass/nickel cable gland
G	M20 with stainless steel cable gland
Code	Approvals
M	Micro Motion Standard (no approval)
U	UL
C	CSA (Canada only)
A	CSA C-US (US and Canada)
Z	ATEX — Equipment Category 2 (Zone 1 — Increased safety terminal compartment)
F	ATEX — Equipment Category 2 (Zone 1 — Flameproof terminal compartment)
P ⁽²⁾	NEPSI — Equipment Category 2 (Zone 1 - Flameproof terminal compartment)
K ⁽²⁾	NEPSI — Equipment Category 2 (Zone 1 - Increased safety terminal compartment)
I	IECEx Equipment Category 2 (Zone 1 — Flameproof terminal compartment)
Continued on next page	

(1) Mounting code B is not available with conduit connection code C or D.

(2) Must be combined with language code M.

Ordering information — Model 1700 *continued*

Code	Language
A	Danish installation manual; English configuration manual
D	Dutch installation manual; English configuration manual
E	English installation manual; English configuration manual
F	French installation manual; French configuration manual
G	German installation manual; German configuration manual
H	Finnish installation manual; English configuration manual
I	Italian installation manual; English configuration manual
J	Japanese installation manual; English configuration manual
M	Chinese installation manual; Chinese configuration manual
N	Norwegian installation manual; English configuration manual
O	Polish installation manual; English configuration manual
P	Portuguese installation manual; English configuration manual
S	Spanish installation manual; Spanish configuration manual
W	Swedish installation manual; English configuration manual
C	Czech installation manual; English configuration manual
B	Hungarian CE requirements document; English installation and configuration manuals
K	Slovak CE requirements document; English installation and configuration manuals
T	Estonian CE requirements document; English installation and configuration manuals
U	Greek CE requirements document; English installation and configuration manuals
L	Latvian CE requirements document; English installation and configuration manuals
V	Lithuanian CE requirements document; English installation and configuration manuals
Y	Slovenian CE requirements document; English installation and configuration manuals
Code	Software options 1
Z	Flow variable (standard)
Code	Software options 2
Z	No software options 2
C ⁽¹⁾	Meter verification, structural integrity method
S ⁽²⁾	Safety certification of 4–20 mA output per IEC 61508
Code	Factory options
Z	Standard product
X	ETO product
Typical Model Number: 1700 I 1 1 A D M E Z C Z	

(1) Requires transmitter to be connected to a sensor with an enhanced core processor.

(2) Available only with output codes A and D.

Ordering information — Model 2700

Model	Product description
2700	Micro Motion Coriolis MVD multivariable flow and density transmitter
Code	Mounting
R	4-wire remote mount transmitter
I	Integral mount transmitter
B ⁽¹⁾	4-wire remote mount transmitter with 9-wire remote core processor (includes 10 ft. [3 m] CFEPS cable)
C	9-wire remote transmitter (requires sensor with junction box; includes 10 ft. [3 m] CFEPS cable)
Code	Power
1	18 to 100 VDC or 85 to 265 VAC; self switching
Code	Display
1	Dual line display for process variables and totalizer reset
2	Backlit dual line display for process variables and totalizer reset
3	No display
Code	Output options
A	Analog outputs: one mA; one frequency/discrete; RS485
B	Analog outputs: one mA; two configurable I/O channels — default configuration of 2 mA, 1 FO
C	Analog outputs: one mA; two configurable I/O channels — custom configuration
D	Intrinsically safe analog outputs: two mA, one frequency/discrete
E	FOUNDATION fieldbus H1 with standard function blocks (4 × AI, 1 × AO, 1 × Integrator)
G ⁽²⁾	PROFIBUS-PA
Code	Conduit connections
B	1/2-inch NPT — no gland
C ⁽¹⁾	1/2-inch NPT with brass/nickel cable gland
D ⁽¹⁾	1/2-inch NPT with stainless steel cable gland
E	M20 — no gland
F	M20 with brass/nickel cable gland
G	M20 with stainless steel cable gland
Code	Approvals
M	Micro Motion Standard (no approval)
U	UL
C	CSA (Canada only)
A	CSA C-US (US and Canada)
Z	ATEX — Equipment Category 2 (Zone 1 — Increased safety terminal compartment)
F	ATEX — Equipment Category 2 (Zone 1 — Flameproof terminal compartment)
P ⁽³⁾	NEPSI — Equipment Category 2 (Zone 1 - Flameproof terminal compartment)
K ⁽³⁾	NEPSI — Equipment Category 2 (Zone 1 - Increased safety terminal compartment)
I	IECEx Equipment Category 2 (Zone 1 — Flameproof terminal compartment)
Continued on next page	

(1) Mounting code B is not available with conduit connection code C or D.

(2) Output code G not available with Software Options 2 Code C.

(3) Must be combined with language code M.

Ordering information — Model 2700 *continued*

Code	Language
A	Danish installation manual; English configuration manual
D	Dutch installation manual; English configuration manual
E	English installation manual; English configuration manual
F	French installation manual; French configuration manual
G	German installation manual; German configuration manual
H	Finnish installation manual; English configuration manual
I	Italian installation manual; English configuration manual
J	Japanese installation manual; English configuration manual
M	Chinese installation manual; Chinese configuration manual
N	Norwegian installation manual; English configuration manual
O	Polish installation manual; English configuration manual
P	Portuguese installation manual; English configuration manual
S	Spanish installation manual; Spanish configuration manual
W	Swedish installation manual; English configuration manual
C	Czech installation manual; English configuration manual
B	Hungarian CE requirements document; English installation and configuration manuals
K	Slovak CE requirements document; English installation and configuration manuals
T	Estonian CE requirements document; English installation and configuration manuals
U	Greek CE requirements document; English installation and configuration manuals
L	Latvian CE requirements document; English installation and configuration manuals
V	Lithuanian CE requirements document; English installation and configuration manuals
Y	Slovenian CE requirements document; English installation and configuration manuals
Code	Software options 1
Z	Flow & density variables (standard)
G ⁽¹⁾	Enhanced density measurement
A ⁽²⁾	Petroleum measurement
X ⁽³⁾	ETO software option 1
Code	Software options 2
Z	No software options 2
C ⁽⁴⁾	Meter verification, structural integrity method
W ⁽⁵⁾	Weights and measures custody transfer
A ⁽⁶⁾	Regulatory control suite: standard fieldbus function blocks plus 1 × PID function block
X ⁽³⁾	ETO software option 2
S ⁽⁷⁾	Safety certification of 4–20 mA output per IEC 61508
Code	Factory options
Z	Standard product
X	ETO product
Typical Model Number: 2700 I 1 1 A D M E Z C Z	

(1) Available only with output option code E.

(2) Not available with output option code G.

(3) Requires factory option X.

(4) Requires transmitter to be connected to a sensor with an enhanced core processor.

(5) Available only with output option codes A, B, or C.

(6) Available only with output option code E.

(7) Available only with output option codes A, B, C, or D.

Ordering information — Model 1500

Model	Product description
1500	Micro Motion Coriolis MVD single variable flow transmitter
Code	Mounting
D	4-wire remote 35 mm DIN rail transmitter
B	4-wire remote 35 mm DIN rail transmitter with 9-wire remote core processor (includes 10 ft. [3 m] CFEPS cable)
Code	Power
3	19.2 to 28.8 VDC
Code	Conduit connections
A	None (for use with mounting option code D)
B ⁽¹⁾	1/2-inch NPT remote core processor — no gland
E ⁽¹⁾	M20 remote core processor — no gland
F ⁽¹⁾	Remote core processor — brass/nickel cable gland
G ⁽¹⁾	Remote core processor — stainless steel cable gland
Code	Output options
A	One mA; one frequency; RS-485
Code	Terminals
B	Screw terminals
Code	Approvals
M	Micro Motion Standard (no approval)
C	CSA (Canada only)
A	CSA C-US (US and Canada)
B	ATEX — Safe area with intrinsically safe sensor outputs
P ⁽²⁾	NEPSI — Safe area
Continued on next page	

(1) Available with mounting option code B only.

(2) Must be combined with language code M.

Ordering information — Model 1500 *continued*

Code	Language
A	Danish installation manual; English configuration manual
D	Dutch installation manual; English configuration manual
E	English installation manual; English configuration manual
F	French installation manual; French configuration manual
G	German installation manual; German configuration manual
H	Finnish installation manual; English configuration manual
I	Italian installation manual; English configuration manual
J	Japanese installation manual; English configuration manual
M	Chinese installation manual; Chinese configuration manual
N	Norwegian installation manual; English configuration manual
O	Polish installation manual; English configuration manual
P	Portuguese installation manual; English configuration manual
S	Spanish installation manual; Spanish configuration manual
W	Swedish installation manual; English configuration manual
C	Czech installation manual; English configuration manual
B	Hungarian CE requirements document; English installation and configuration manuals
K	Slovak CE requirements document; English installation and configuration manuals
T	Estonian CE requirements document; English installation and configuration manuals
U	Greek CE requirements document; English installation and configuration manuals
L	Latvian CE requirements document; English installation and configuration manuals
V	Lithuanian CE requirements document; English installation and configuration manuals
Y	Slovenian CE requirements document; English installation and configuration manuals
Code	Software options 1
Z	Flow variable (standard)
X ⁽¹⁾	ETO software option 1
Code	Software options 2
Z	No software option 2
C ⁽²⁾	Meter verification, structural integrity method
X ⁽¹⁾	ETO software option 2
Code	Factory options
Z	Standard product
X	ETO product
Typical Model Number: 1500 D 3 A A B M E Z C Z	

(1) Requires factory option X.

(2) Requires transmitter to be connected to a sensor with an enhanced core processor.

Ordering information — Model 2500

Model	Product description
2500	Micro Motion Coriolis MVD multivariable flow and density transmitter
Code	Mounting
D	4-wire remote 35 mm DIN rail transmitter
B	4-wire remote 35 mm DIN rail transmitter with 9-wire remote core processor (includes 10 ft. [3 m] CFEPS cable)
Code	Power
3	19.2 to 28.8 VDC
Code	Conduit connections
A	None (for use with mounting option code D)
B ⁽¹⁾	1/2-inch NPT remote core processor — no gland
E ⁽¹⁾	M20 remote core processor — no gland
F ⁽¹⁾	Remote core processor — brass/nickel cable gland
G ⁽¹⁾	Remote core processor — stainless steel cable gland
Code	Output options
B	One mA; two configurable I/O channels; RS485 — default configuration of 2 mA, 1 FO
C	One mA; two configurable I/O channels; RS485 — custom configuration
Code	Terminals
B	Screw terminals
Code	Approvals
M	Micro Motion Standard (no approval)
C	CSA (Canada only)
A	CSA C-US (US and Canada)
B	ATEX — Safe area with intrinsically safe sensor outputs
P ⁽²⁾	NEPSI — Safe area
Continued on next page	

(1) Available with mounting option code B only.

(2) Must be combined with language code M.

Ordering options — Model 2500 *continued*

Code	Language
A	Danish installation manual; English configuration manual
D	Dutch installation manual; English configuration manual
E	English installation manual; English configuration manual
F	French installation manual; French configuration manual
G	German installation manual; German configuration manual
H	Finnish installation manual; English configuration manual
I	Italian installation manual; English configuration manual
J	Japanese installation manual; English configuration manual
M	Chinese installation manual; Chinese configuration manual
N	Norwegian installation manual; English configuration manual
O	Polish installation manual; English configuration manual
P	Portuguese installation manual; English configuration manual
S	Spanish installation manual; Spanish configuration manual
W	Swedish installation manual; English configuration manual
C	Czech installation manual; English configuration manual
B	Hungarian CE requirements document; English installation and configuration manuals
K	Slovak CE requirements document; English installation and configuration manuals
T	Estonian CE requirements document; English installation and configuration manuals
U	Greek CE requirements document; English installation and configuration manuals
L	Latvian CE requirements document; English installation and configuration manuals
V	Lithuanian CE requirements document; English installation and configuration manuals
Y	Slovenian CE requirements document; English installation and configuration manuals
Code	Software options 1
Z	Flow and density variables (standard)
A	Petroleum measurement
X ⁽¹⁾	ETO software option 1
Code	Software options 2
Z	No software options 2
C ⁽²⁾	Meter verification, structural integrity method
W	Weights and measures custody transfer (requires external sealing for approval)
X ⁽¹⁾	ETO software option 2
Code	Factory options
Z	Standard product
X	ETO product
Typical Model Number: 2500 D 3 3 B B M E Z C Z	

(1) Requires factory option X.

(2) Requires transmitter to be connected to a sensor with an enhanced core processor.

Micro Motion—The undisputed leader in flow and density measurement



World-leading Micro Motion measurement solutions from Emerson Process Management deliver what you need most:

Technology leadership

Micro Motion introduced the first reliable Coriolis meter in 1977. Since that time, our ongoing product development has enabled us to provide the highest performing measurement devices available.

Product breadth

From compact, drainable process control to high flow rate fiscal transfer—look no further than Micro Motion for the widest range of measurement solutions. With the addition of Solartron® liquid and gas density meters, Micro Motion truly is the world leader.

Unparalleled value

Benefit from expert phone, field, and application service and support made possible by more than 500,000 meters installed worldwide and 30 years of flow and density measurement experience.

 www.micromotion.com

© 2007 Micro Motion, Inc. All rights reserved. Micro Motion is committed to continuous product improvement. As a result, all specifications are subject to change without notice. ELITE and ProLink are registered trademarks, and MVD and MVD Direct Connect are trademarks of Micro Motion, Inc., Boulder, Colorado. Micro Motion is a registered trade name of Micro Motion, Inc., Boulder, Colorado. The Micro Motion and Emerson logos are trademarks and service marks of Emerson Electric Co. All other trademarks are property of their respective owners.

Emerson Process Management

Micro Motion Americas

Worldwide Headquarters
7070 Winchester Circle
Boulder, Colorado USA 80301
T: 800 522 6277
T: +1 (303) 527 5200
F: +1 (303) 530 8459
Mexico T: 52 55 5366 2622
Argentina T: 54 11 4837 7000
Brazil T: 55 15 3238 3677
Venezuela T: 58 26 1731 3394

Emerson Process Management

Micro Motion Europe/Middle East

Central & Eastern Europe T: +41 41 7686 111
Dubai T: 971-4 8835235
France T: 0800 917 901
Germany T: 0800 182 5347
Italy T: 8008 77334
The Netherlands T: (31) 318 495 555
U.K. T: 0870 240 1978
Russia/CIS T: +7 495 981 9811

Emerson Process Management

Micro Motion Asia Pacific

Australia T: (61) 3 9721 0200
China T: (86) 21 3895 4788
India T: (91) 22 5662 0566
Japan T: (81) 3 5769 6803
Korea T: (82) 2 3438 4600
Singapore T: (65) 6 777 8211

