

Rosemount 8700 Series Magnetic Flowmeter Systems

THE 8700 E-SERIES...

- Industry leading performance with standard reference accuracy of 0.25% of rate with an optional High Accuracy of 0.15% of rate.
- Rosemount 8732 HART Transmitter - Integral-mount design, backlit display, and explosion-proof housing. Available with I.S. Outputs, Device Diagnostics, and Internal Meter Verification to improve reliability and performance
- Rosemount 8712 HART Transmitter - available with Device Diagnostics to improve reliability and performance. Quick setup with easy-to-use local operator interface
- Rosemount 8712H/8707 High-Signal System - Pulsed DC solutions for the most demanding flow measurement applications
- Rosemount 8705 Flanged flowtube sensor - Fully welded flowtube sensor for maximum protection (standard ISO lay length)
- Rosemount 8711 Wafer flowtube sensor - Economical, compact, and lightweight flowtube sensor, provided with alignment rings for easy installation
- Rosemount 8721 Hygienic flowtube sensor - Specifically designed for food, beverage, and life sciences applications
- Rosemount 8742 FOUNDATION™ fieldbus Transmitter - Integral-mount design available with Device Diagnostics



Contents

Product Offering Overview	page 2
Specifications	page 15
Product Certifications	page 34
Dimensional Drawings	page 47
Magnetic Flowmeter Sizing.	page 60
Product Selection Guide.	page 62
Ordering Information.	page 65
Configuration Data Sheets	page 85

Rosemount 8700 Series

Rosemount 8700 Series System Overview

Rosemount 8732E

The Rosemount 8732E transmitter has multiple diagnostic suites available. Best in class performance coupled with advanced diagnostics provides unparalleled process management capabilities. With an optional backlit 2 line by 16 character local operator interface, the transmitter can be configured by optical switches to simplify adjustments in hazardous environments without removing the cover.



Rosemount 8742C

The Rosemount 8742C is for applications that require FOUNDATION fieldbus output protocol. Available with optional diagnostics that optimize meter performance and improve process management.



Rosemount 8712D

The remote mount 8712 transmitter brings diagnostics to any HART/ 4-20mA system that can change how magmeters are installed, maintained, and verified. The Rosemount 8712 also features an easy-to-use operator interface, with quick access to all diagnostic information, and instant access to basic configuration setup through dedicated keys.



Rosemount 8714D

The Rosemount 8714D Calibration Standard attaches to an 8712D, 8732, or 8742C transmitter's flowtube sensor connections to ensure traceability to NIST standards and long-term accuracy of the flowmeter system. The 8714D is not compatible with the 8712H High-Signal transmitter



Product Data Sheet

00813-0100-4727, Rev RA

December 2007

Rosemount 8700 Series

Rosemount 8705 Flanged Flowtube Sensors

All flanged flowtube sensors are fabricated from stainless and carbon steel and welded to provide a hermetic seal that protects against moisture and other contaminants. Sizes range from 1/2 in. (15 mm) to 36 in. (900 mm). The sealed housing ensures maximum flowtube sensor reliability by protecting all internal components and wiring from the most hostile environments.



Rosemount 8711 Wafer Flowtube Sensors

The flangeless design of the 8711 wafer flowtube sensor makes it an economical, compact, and lightweight alternative to flanged magnetic flowmeters. Alignment rings provided with every 8711, center the flowtube sensor in the process line and makes installation easier.



Rosemount 8707/8712H High-Signal Magmeter System ⁽¹⁾

The 8707 High-Signal Flowtube Sensor, used in conjunction with the 8712H High-Signal Transmitter, forms the Rosemount High-Signal Magnetic Flowmeter System. This system provides stable flow measurement in the most difficult high-noise applications while maintaining the benefits of DC technology. The increased signal strength of the high-signal system is made possible through a combination of flowtube sensor coil design that incorporates the most advanced materials and an extremely efficient and innovative coil drive circuit. The increased signal strength of the Rosemount high-signal system, coupled with advanced signal processing and superior filtering techniques, provide the solution to demanding flow measurement applications.



Rosemount 8721 Hygienic Flowtube Sensors

The 8721 hygienic flowtube sensor is specifically designed for the demanding applications in food, beverage, and life sciences. The robust, all-welded, full diameter flowtube sensor is constructed of FDA approved materials and is authorized to display the 3-A Symbol (Authorization #1222) is certified by EHEDG (#C03-5229) and is approved for use in FDA Grade A milk meter based timing loops (M-b 350). Sizes range from 1/2" (15mm) to 4" (100mm) and are available in a variety of industry standard process connections.



(1) The high-signal magmeter system is not currently available with CE mark.

Rosemount 8700 Series

Rosemount Magmeter Diagnostics Power PlantWeb



Rosemount Mag Diagnostics Power PlantWeb to Reduce Cost & Improve Output by Enabling New Practices

Rosemount Magmeters provide device diagnostics that powers PlantWeb and informs the user of abnormal situations throughout the life of the meter - from Installation to Maintenance and Meter Verification. With Rosemount Magmeter diagnostics enabled, users can change their practices to improve plant availability and throughput, and reduce costs through simplified installation, maintenance and troubleshooting.

Diagnostics	Mag User Practice	8732E HART	8712D HART	8712H HART	8742 FOUNDATION fieldbus
Basic					
Empty Pipe	Process Management	•	•	•	•
Electronics Temperature	Maintenance	•	•		
Coil Fault	Maintenance	•	•	•	•
Transmitter Faults	Maintenance	•	•	•	•
Reverse Flow	Process Management	•	•	•	•
Advanced (Suite 1)		DA1 Option	DA1 Option	N/A	D01 Option
High Process Noise	Process Management	•	•		•
Grounding/Wiring Fault	Installation	•	•		•
Electrode Fault	Maintenance				•
Advanced (Suite 2)		DA2 Option	N/A	N/A	N/A
8714i Calibration Verification™	Calibration Verification	•			
4-20 mA Loop Verification	Maintenance	•			

OPTIONS FOR ACCESSING DIAGNOSTICS

Rosemount Magmeter Diagnostics can be accessed through the Local Operator Interface (LOI)⁽¹⁾, the 375 Field Communicator, and AMS™ Suite: Intelligent Device Manager.

Access diagnostics through the LOI for quicker installation, maintenance, and meter verification⁽¹⁾



Rosemount Magmeter Diagnostics are available through the LOI to make maintenance of every magmeter easier.

Access diagnostics through AMS Intelligent Device Manager for the ultimate value

The value of the diagnostics increases significantly when AMS is used. Now the user gets a simplified screen flow and procedures for how to respond to the diagnostic messages.

(1) Not available for the 8742 FOUNDATION fieldbus transmitter.

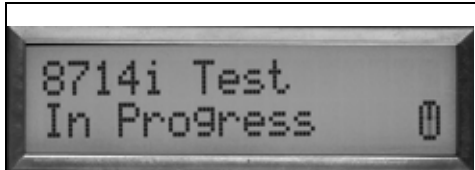
8714i Calibration Verification Improves Magnetic Flowmeter Verification Practice
 Diagnostic in LOI

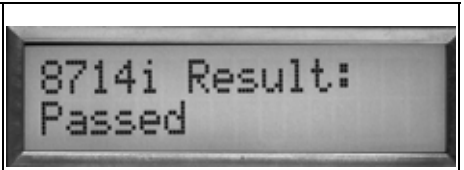
		
<p><i>8714i Calibration Verification checks transmitter and flowtube sensor characteristics.</i></p>	<p><i>Deviation from baseline values are reported.</i></p>	<p><i>Meter Calibration is verified.</i></p>

Diagnostic in AMS

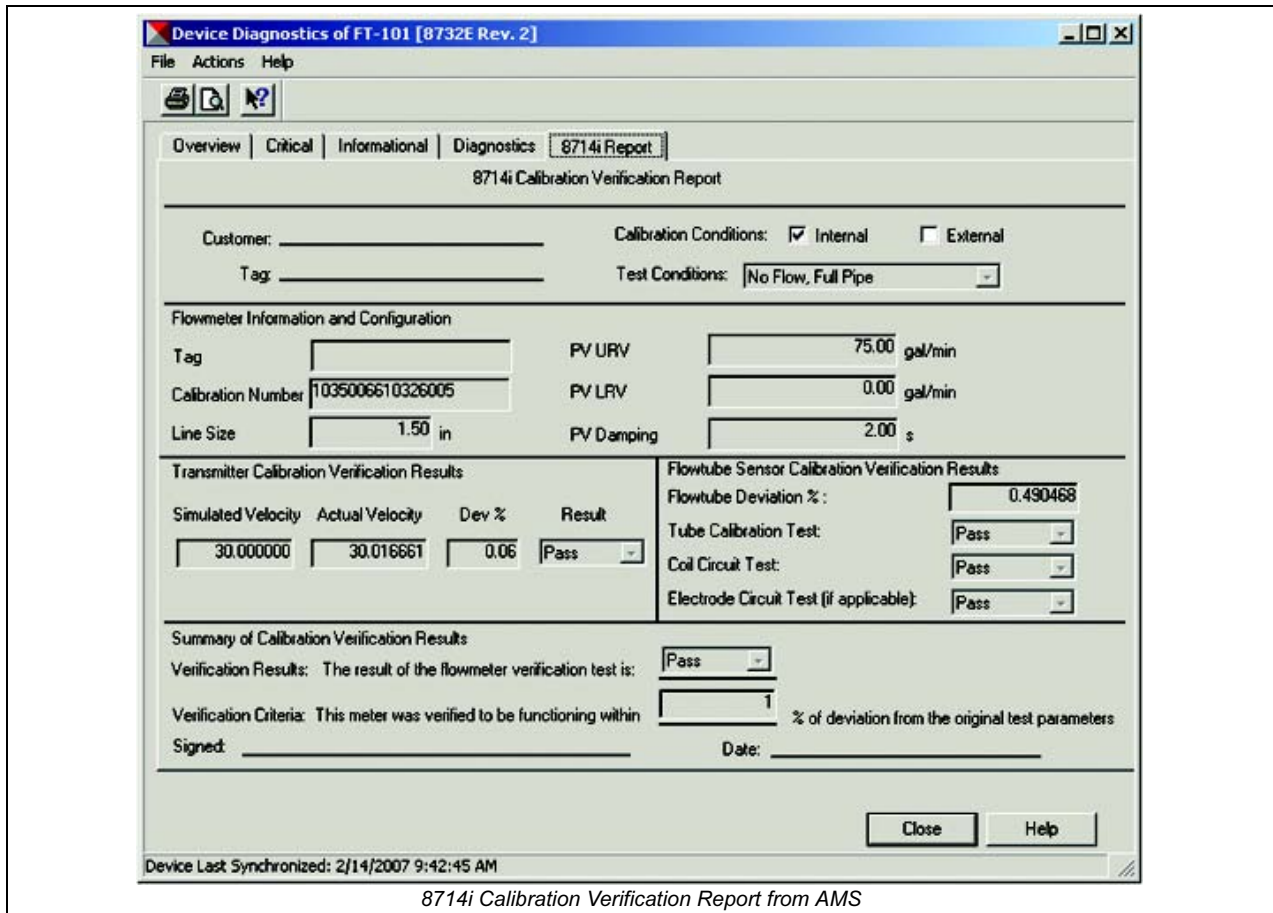

Device Diagnostics of FT-101 [8732E Rev. 2]

File Actions Help

Overview Critical Informational Diagnostics **8714i Report**

8714i Calibration Verification Report

Customer: _____ Calibration Conditions: Internal External
 Tag: _____ Test Conditions:

Flowmeter Information and Configuration

Tag: _____ PV URV: gal/min
 Calibration Number: PV LRV: gal/min
 Line Size: in PV Damping: s

Transmitter Calibration Verification Results				Flowtube Sensor Calibration Verification Results	
Simulated Velocity	Actual Velocity	Dev %	Result	Flowtube Deviation % :	
<input type="text" value="30.000000"/>	<input type="text" value="30.016661"/>	<input type="text" value="0.06"/>	<input type="text" value="Pass"/>	<input type="text" value="0.490468"/>	
				Tube Calibration Test:	<input type="text" value="Pass"/>
				Coil Circuit Test:	<input type="text" value="Pass"/>
				Electrode Circuit Test (if applicable):	<input type="text" value="Pass"/>

Summary of Calibration Verification Results

Verification Results: The result of the flowmeter verification test is:

Verification Criteria: This meter was verified to be functioning within % of deviation from the original test parameters

Signed: _____ Date: _____

Close Help

Device Last Synchronized: 2/14/2007 9:42:45 AM

8714i Calibration Verification Report from AMS

Rosemount 8700 Series

Grounding/ Wiring Diagnostic Improves Installation Practices Diagnostic in LOI

 <p>3.45 Ft/Sec Grnd/Wire Fault</p> <p>DISPLAY CONTROL TOTALIZER DATA ENTRY</p> <p><i>Grounding and wiring fault displays on LOI.</i></p>	 <p>Error Messages: Grnd/Wire Fault</p> <p>DISPLAY CONTROL TOTALIZER DATA ENTRY</p> <p><i>Error messages under Diagnostic menu.</i></p>	 <p>Line Noise: 5.43 mV</p> <p>DISPLAY CONTROL TOTALIZER DATA ENTRY</p> <p><i>Line noise value can be viewed. If line noise is > 5 mV, Diagnostic is tripped.</i></p>
--	---	---

Diagnostic in AMS

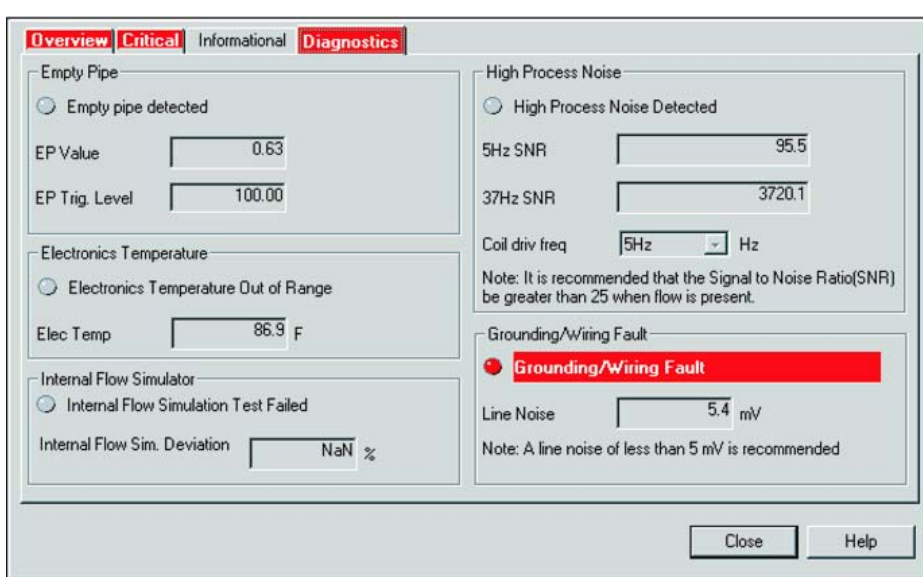

The AMS status screen displays several diagnostic sections:

- Empty Pipe:** Empty pipe detected (radio button), EP Value: 0.63, EP Trig. Level: 100.00
- Electronics Temperature:** Electronics Temperature Out of Range (radio button), Elec Temp: 86.9 F
- Internal Flow Simulator:** Internal Flow Simulation Test Failed (radio button), Internal Flow Sim. Deviation: NaN %
- High Process Noise:** High Process Noise Detected (radio button), 5Hz SNR: 95.5, 37Hz SNR: 3720.1, Coil driv freq: 5Hz Hz. Note: It is recommended that the Signal to Noise Ratio(SNR) be greater than 25 when flow is present.
- Grounding/Wiring Fault:** Grounding/Wiring Fault (radio button, highlighted in red), Line Noise: 5.4 mV. Note: A line noise of less than 5 mV is recommended.

Buttons: Close, Help

Grounding and wiring is tripped and shown in AMS status screen.

High Process Noise Diagnostic Improves Process Management
 Diagnostic in LOI

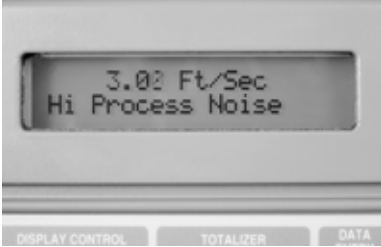
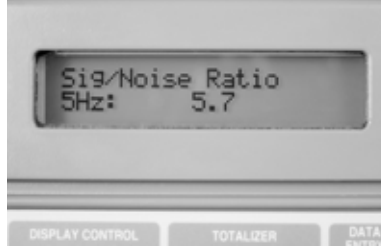
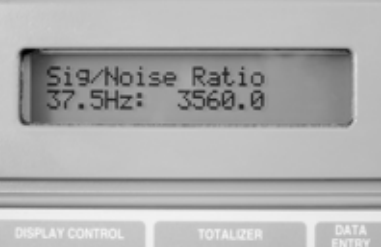
		
<p>LOI indicates high process noise is detected.</p>	<p>Signal-to-noise ratio (SNR) is viewed in Diagnostic menu. If < 25:1, diagnostic tripped.</p>	<p>Improved SNR and signal stability by moving coil drive frequency from 5 Hz to 37 Hz.</p>

Diagnostic in AMS

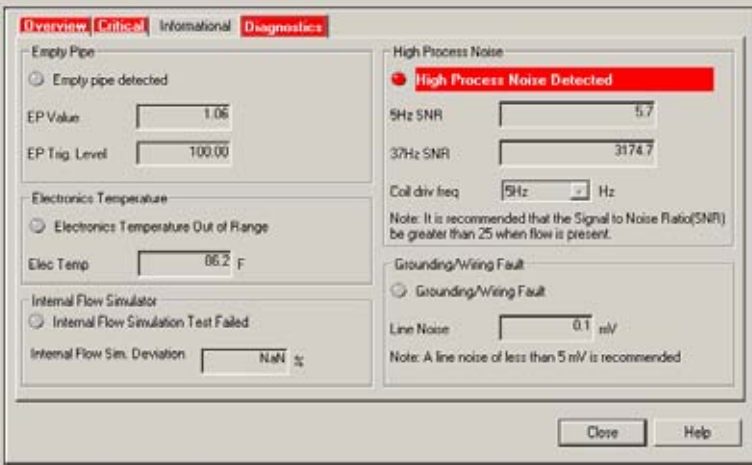

The screenshot shows the 'Diagnostics' tab in the AMS interface. A red banner at the top right indicates 'High Process Noise Detected'. Below this, the 'High Process Noise' section displays '5Hz SNR' as 5.7 and '37Hz SNR' as 3174.7. The 'Coil div freq' is set to 5Hz. A note states: 'Note: It is recommended that the Signal to Noise Ratio(SNR) be greater than 25 when flow is present.' Other diagnostic sections include 'Empty Pipe', 'Electronics Temperature', and 'Internal Flow Simulator'.

AMS status screen indicates high process noises detected and shows SNR at both coil drive frequencies.

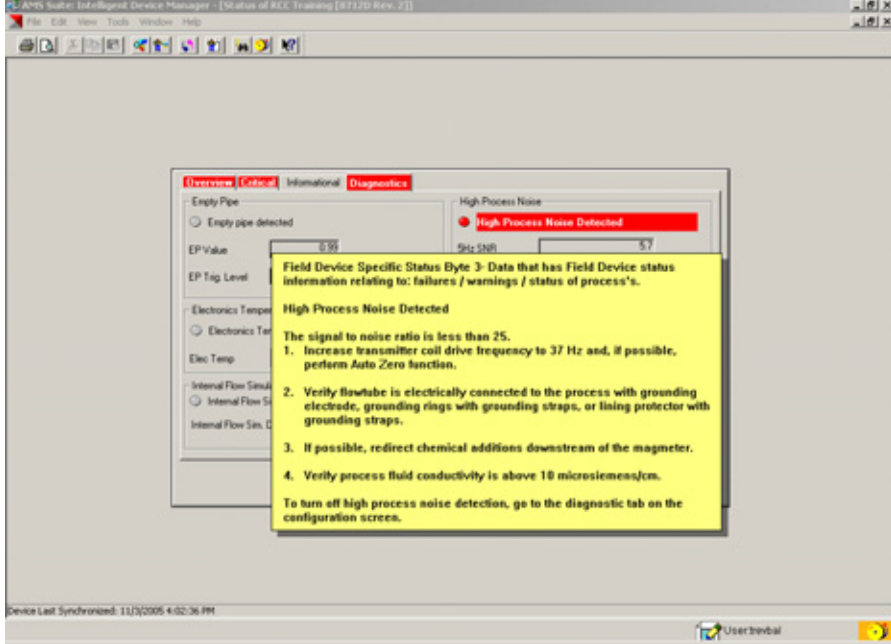

The screenshot shows the 'AMS Subsystem Intelligent Device Manager' window with a help popup. The popup title is 'High Process Noise Detected' and contains the following text:

Field Device Specific Status Byte 3- Data that has Field Device status information relating to: failures / warnings / status of process's.

High Process Noise Detected

The signal to noise ratio is less than 25.

1. Increase transmitter coil drive frequency to 37 Hz and, if possible, perform Auto Zero function.
2. Verify flowtube is electrically connected to the process with grounding electrode, grounding rings with grounding straps, or lining protector with grounding straps.
3. If possible, redirect chemical additions downstream of the magnet.
4. Verify process fluid conductivity is above 18 microsiemens/cm.

To turn off high process noise detection, go to the diagnostic tab on the configuration screen.





AMS help provides procedure for adjusting mag coil drive frequency to improve signal stability.

Rosemount 8700 Series

Rosemount 8700 Series Product Specifications Overview





Listed below are tables that outline some of the basic performance, physical, and functional specifications of the Rosemount 8700 Series Magnetic Flowmeter products. Table 1 provides an overview of the Rosemount 8700 Series Transmitter products. Table 2 provides an overview of the Rosemount 8700 Series Flowtube Sensor products.

TABLE 1. Rosemount 8700 Series Transmitter Specifications

	Model	Base Accuracy ⁽¹⁾	Mounting	Power Supply	User Interface	Communication Protocol	Diagnostics	Flowtube Sensor Compatibility	Page for Detailed Specifications	Page for Ordering Information
	8732E	0.25% Standard 0.15% High Accuracy Option	Integral or Remote	Global AC or DC	4 Optical Switch LOI	HART	Basic plus Optional DA1 and DA2 Suite	All Rosemount plus other manufacturers	page 10	page 65
	8712D	0.25% Standard 0.15% High Accuracy Option	Remote	Global AC or DC	Dedicated 15 Button LOI	HART	Basic plus optional DA1 Suite	All Rosemount plus other manufacturers	page 15	page 67
	8712H	0.5% Standard 0.25% High Accuracy Option	Remote	115 V AC	Dedicated 15 Button LOI	HART	Basic	8707 Only	page 15	page 68
	8742C	0.3% Standard 0.2% High Accuracy Option	Integral or Remote	Global AC or DC	Display Only	FOUNDATION fieldbus	Basic plus Optional D01 Suite	All Rosemount	page 20	page 69

(1) For complete accuracy specifications, please refer to the transmitter detailed specifications.

TABLE 2. Rosemount 8700 Series Flowtube Sensor Specifications

	Model	Style	Base Accuracy ⁽¹⁾	Line Sizes	Coil Drive Power	Design Features	Page for Detailed Specifications	Page for Ordering Information
	8705	Flanged	0.25% Standard 0.15% High Accuracy Option	0.5 to 36 in. (15 to 900 mm)	Pulsed DC	Standard Process Design	page 23	page 71
	8707	High-Signal (Flanged)	0.5% Standard 0.25% High Accuracy Option	3 to 36 in. (15 to 900 mm)	High-Signal Pulsed DC	Superior signal stability for Noisy Applications	page 23	page 76
	8711	Wafer	0.25% Standard 0.15% High Accuracy Option	0.15 to 8 in. (4 to 200 mm)	Pulsed DC	Compact, Light Weight	page 28	page 79
	8721	Hygienic	0.5% Standard 0.25% High Accuracy Option	0.5 to 4 in. (15 to 100 mm)	Pulsed DC	3-A and EHEDG CIP/SIP	page 30	page 81

(1) For complete accuracy specifications, please refer to the flowtube sensor detailed specifications.

Rosemount 8700 Series



Rosemount 8732E Transmitter Specifications

Functional Specifications

Flowtube Sensor Compatibility

Compatible with Rosemount 8705, 8711, 8721, and 570TM flowtube sensors. Compatible with Rosemount 8707 flowtube sensor with D2 Dual calibration option. Compatible with AC and DC powered flowtube sensors of other manufacturers.

Compatible with Rosemount 8707 flowtube sensor with D2 Dual Calibration Option.

Compatible with AC and DC powered flowtube sensors of other manufacturers.

Flowtube Sensor Coil Resistance

350 Ω maximum

Flow Rate Range

Capable of processing signals from fluids that are traveling between 0.04 and 39 ft/s (0.01 to 12 m/s) for both forward and reverse flow in all flowtube sensor sizes. Full scale continuously adjustable between -39 and 39 ft/s (-12 to 12 m/s).

Conductivity Limits

Process liquid must have a conductivity of 5 microsiemens/cm (5 micromhos/cm) or greater for 8732E. Excludes the effect of interconnecting cable length in remote mount transmitter installations.

Power Supply

90 -250 V AC \pm 10%, 50-60 Hz or 12-42 V DC

AC Power Supply Requirements

Units powered by 90-250 V AC have the following power requirements.

DC Supply Current Requirements

Units powered by 12-42 V DC power supply may draw up to 1 amp of current steady state.

FIGURE 1. DC Current Requirements

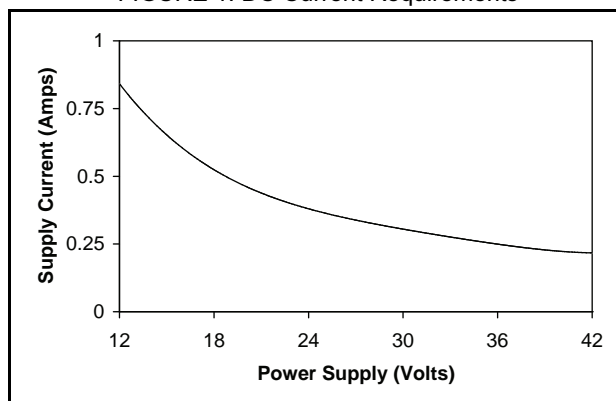

DC Load Limitations (Analog Output)

Maximum loop resistance is determined by the voltage level of the external power supply, as described by:

FIGURE 2. DC Load Limitations

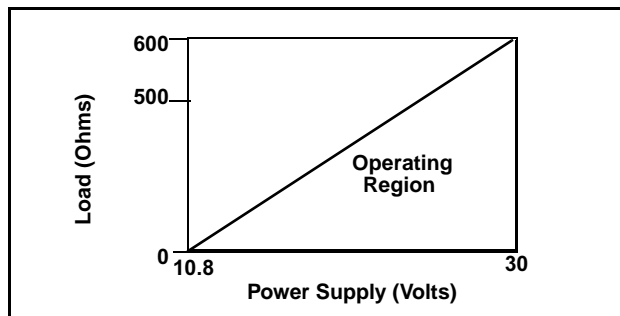

$$R_{\max} = 31.25 (V_{ps} - 10.8)$$

V_{ps} = Power Supply Voltage (Volts)
 R_{\max} = Maximum Loop Resistance (Ohms)

Product Data Sheet

00813-0100-4727, Rev RA

December 2007

Rosemount 8700 Series

NOTE

HART Communication requires a minimum loop resistance of 250 ohms.

Installation Coordination

Installation (overvoltage) Category II

Power Consumption

10 watts maximum

Switch-on current

AC: Maximum 26 A (< 5 ms) at 250 V AC

DC: Maximum 30 A (< 5 ms) at 42 V DC

Ambient Temperature Limits

Operating

–58 to 165 °F (–50 to 74 °C) without local operator interface

13 to 149 °F (–25 to 65 °C) with local operator interface

Storage

–40 to 185 °F (–40 to 85 °C)

–22 to 176 °F (–30 to 80 °C) with local operator interface

Humidity Limits

0–100% RH to 150 °F (65 °C)

Enclosure Rating

NEMA 4X CSA Type 4X, IEC 60529, IP66 (transmitter), Pollution Degree 2

Output Signals

Analog Output Adjustment⁽¹⁾

4–20 mA, switch-selectable as internally or externally powered 10 to 30 V DC; 0 to 600 Ω load.

Engineering units—lower and upper range values are user-selectable.

Output automatically scaled to provide 4 mA at lower range value and 20 mA at upper range value. Full scale continuously adjustable between –39 and 39 ft/s (–12 to 12 m/sec), 1 ft/s (0.3 m/s) minimum span.

HART Communications, digital flow signal, superimposed on 4–20 mA signal, available for control system interface. 250 Ω required for HART communications.

Scalable Frequency Adjustment⁽¹⁾

0–10,000 Hz, switch-selectable as internally or externally powered 10 to 30 V DC, transistor switch closure up to 5.75 w. Pulse value can be set to equal desired volume in selected engineering units. Pulse width adjustable from 0.5 to 100 m/s. Local operator interface automatically calculates and displays maximum allowable output frequency.

(1) For transmitters with intrinsically safe outputs, power must be supplied externally.

Rosemount 8700 Series

Optional Digital Output Function

Externally powered at 5 to 24 V DC, transistor switch closure up to 3 W to indicate either:

Reverse Flow:

Activates switch closure output when reverse flow is detected. The reverse flow rate is displayed.

Zero Flow:

Activates switch closure output when flow goes to 0 ft/s.

Empty Pipe:

Activates switch closure output when empty pipe is detected.

Transmitter Fault:

Activates switch closure output when a transmitter fault is detected.

Optional Digital Input Function

Externally powered at 5 to 24 V DC, transistor switch closure up to 3 W to indicate either:

Net Total Reset:

Resets the net totalizer value to zero.

Positive Zero Return (PZR):

Simulates zero-flow condition.

Security Lockout

Security lockout switch on the electronics board can be set to deactivate all LOI and HART-based communicator functions to protect configuration variables from unwanted or accidental change.

Display Lockout

All optical switches on the display can be locked locally from the display layout configuration screen by holding the upper right optical switch for 10 seconds. The display can be reactivated holding the same switch for 10 seconds.

Output Testing

Analog Output Test

Transmitter may be commanded to supply a specified current between 3.5 and 23 mA.

Pulse Output Test

Transmitter may be commanded to supply a specified frequency between 1 and 10,000 Hz.

Turn-on Time

5 minutes to rated accuracy from power up; 5 seconds from power interruption.

Start-up Time

50 ms from zero flow.

Low Flow Cutoff

Adjustable between 0.01 and 38.37 ft/s (0.003 and 11.7 m/s). Below selected value, output is driven to the zero flow rate signal level.

Overrange Capability

Signal output will remain linear until 110% of upper range value or 44 ft/s (13 m/s). The signal output will remain constant above these values. Out of range message displayed on LOI and the HART Communicator.

Damping

Adjustable between 0 and 256 seconds.

Flowtube Sensor Compensation

Rosemount flowtube sensors are flow-calibrated and assigned a calibration factor at the factory. The calibration factor is entered into the transmitter, enabling interchangeability of flowtube sensors without calculations or a compromise in standard accuracy.

8732E transmitters and other manufacturer's flowtube sensors can be calibrated at known process conditions or at the Rosemount NIST-Traceable Flow Facility. Transmitters calibrated on site require a two-step procedure to match a known flow rate. This procedure can be found in the Operations Manual 00809-0100-4662.

Diagnostics

Basic

- Self test
- Transmitter faults
- Analog output test
- Pulse output test
- Tunable empty pipe
- Reverse flow
- Coil circuit fault
- Electronics temperature

Advanced (DA1 Suite)

- Ground/wiring fault
- High process noise

Advanced (DA2 Suite)

- 8714i Calibration Verification
- 4-20 mA loop verification

Performance Specifications

(System specifications are given using the frequency output and with the unit at reference conditions.)

Accuracy

Includes the combined effects of linearity, hysteresis, repeatability, and calibration uncertainty.

Rosemount 8732E with 8705/8707 Flowtube Sensor:

Standard system accuracy is $\pm 0.25\%$ of rate ± 1.0 mm/sec from 0.04 to 6 ft/s (0.01 to 2 m/s); above 6 ft/s (2 m/s), the system has an accuracy of $\pm 0.25\%$ of rate ± 1.5 mm/sec.

Optional high accuracy is $\pm 0.15\%$ of rate ± 1.0 mm/sec from 0.04 to 13 ft/s (0.01 to 4 m/s); above 13 ft/s (4 m/s), the system has an accuracy of $\pm 0.18\%$ of rate.⁽¹⁾

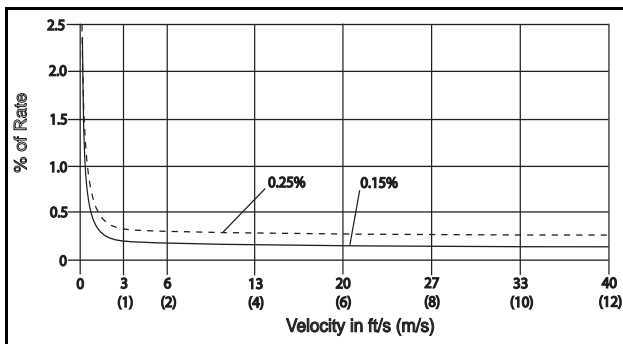

Rosemount 8732E with 8711 Flowtube Sensor:
 Standard system accuracy is $\pm 0.25\%$ of rate ± 2.0 mm/sec from 0.04 to 39 ft/s (0.01 to 12 m/s).

Optional high accuracy is $\pm 0.15\%$ of rate ± 1.0 mm/sec from 0.04 to 13 ft/s (0.01 to 4 m/s); above 13 ft/s (4 m/s), the system has an accuracy of $\pm 0.18\%$ of rate.

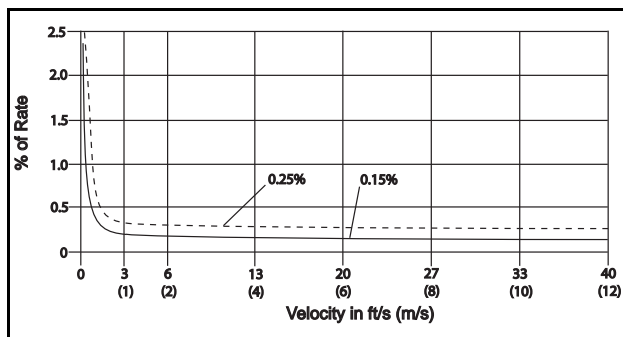

Rosemount 8732E with 8721 Flowtube Sensor:

Standard system accuracy is $\pm 0.5\%$ of rate from 1 to 39 ft/s (0.3 to 12 m/s); between 0.04 and 1.0 ft/s (0.01 and 0.3 m/s), the system has an accuracy of ± 0.005 ft/s (0.0015 m/s).

Optional high accuracy is $\pm 0.25\%$ of rate from 3 to 39 ft/s (1 to 12 m/s).

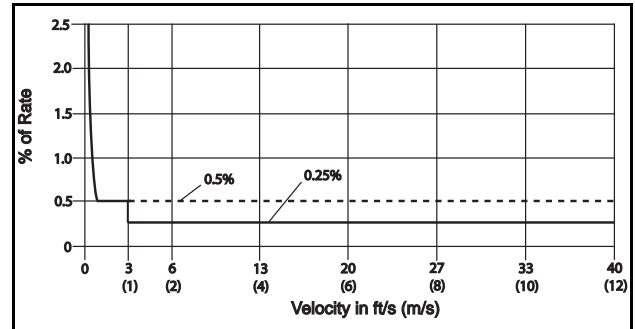

Rosemount 8732E with Legacy 8705 Flowtube Sensors:

Standard system accuracy is $\pm 0.5\%$ of rate from 1 to 39 ft/s (0.3 to 12 m/s); between 0.04 and 1.0 ft/s (0.01 and 0.3 m/s), the system has an accuracy of ± 0.005 ft/s (0.0015 m/s).

Rosemount 8732E with Legacy 8711 Flowtube Sensors:

Standard system accuracy is $\pm 0.5\%$ of rate from 3 to 39 ft/s (1 to 12 m/s); between 0.04 and 3.0 ft/s (0.01 and 1 m/s), the system has an accuracy of ± 0.015 ft/s (0.005 m/s).

Rosemount 8732E with Other Manufacturers' Flowtube Sensors:

When calibrated in the Rosemount Flow Facility, system accuracies as good as 0.5% of rate can be attained.

There is no accuracy specification for other manufacturers' flowtube sensors calibrated in the process line.

Analog Output Effect

Analog output has the same accuracy as frequency output plus an additional $\pm 4\mu\text{A}$.

Vibration Effect

IEC 60770-1

Repeatability

$\pm 0.1\%$ of reading

(1) For Flowtube Sensor sizes greater than 12 in. (300 mm) the high accuracy is $\pm 0.25\%$ of rate from 3 to 39 ft/sec (1 to 12 m/sec).

Rosemount 8700 Series

Response Time (Analog Output)

50 ms maximum response time to step change in input

Stability

±0.1% of rate over six months

Ambient Temperature Effect

±0.25% change over operating temperature range

EMC Compliance

EN61326-1 1997 + A1/A2/A3 (Industrial)
electromagnetic compatibility (EMC) for process and laboratory apparatus.

Physical Specifications

Materials of Construction

Housing

Low copper aluminum, NEMA 4X and IEC 60529 IP66

Pollution Degree 2

Paint

Polyurethane

Cover Gasket

Rubber

Electrical Connections

Two 1/2–14 NPT connections provided on the transmitter housing (optional third connection available). PG13.5 and CM20 adapters are available. Screw terminals provided for all connections. Power wiring connected to transmitter only. Integrally mounted transmitters are factory wired to the flowtube sensor.

Transmitter Weight

Approximately 7 pounds (3.2 kg). Add 1 pound (0.5 kg) for Option Code M4.



Rosemount 8712D/H Transmitter Specifications

Functional Specifications

Flowtube Sensor Compatibility

8712D: Compatible with Rosemount 8705, 8711, 8721, and 570TM flowtube sensors. Compatible with Rosemount 8707 flowtube sensor with D2 Dual calibration option. Compatible with AC and DC powered flowtube sensors of other manufacturers.

8712H: Only compatible with 8707 High-Signal flowtube sensor.

Flowtube Sensor Coil Resistance

Rosemount 8712D: 350 Ω maximum

Rosemount 8712H: 12 Ω maximum

Flow Rate Range

8712D: Capable of processing signals from fluids that are traveling between 0.01 and 39 ft/s (0 to 12 m/s) for both forward and reverse flow in all flowtube sensor sizes. Full scale continuously adjustable between -39 and 39 ft/s (-12 to 12 m/s).

8712H: Capable of processing signals from fluids that are traveling between 0.04 and 30 ft/s (0.01 to 10 m/s) for both forward and reverse flow in all flowtube sensor sizes. Full scale continuously adjustable between -30 and 30 ft/s (-10 to 10 m/s).

Conductivity Limits

Process liquid must have a conductivity of 5 microsiemens/cm (5 micromhos/cm) or greater for Rosemount 8712D. Process liquid must have a conductivity of 50 microsiemens/cm (50 micromhos/cm) for the 8712H. Excludes the effect of interconnecting cable length in remote mount transmitter installations.

Power Supply

Rosemount 8712D: 90-250 V AC \pm 10%, 50-60 Hz or 12-42 V DC

Rosemount 8712H: 115 V AC \pm 10%, 50-60 Hz

DC Load Limitations (Analog Output)

Maximum loop resistance is determined by the voltage level of the external power supply, as described by:

FIGURE 3. DC Load Limitations

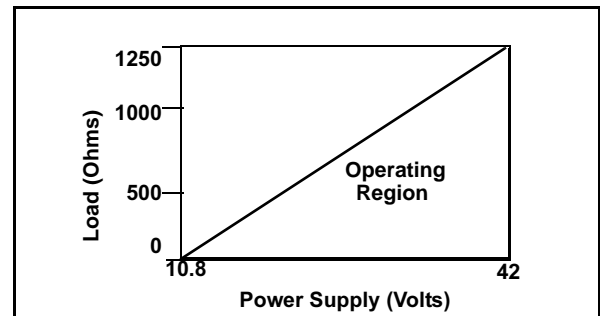

$$R_{\max} = 41.7(V_{\text{ps}} - 10.8)$$

V_{ps} = Power Supply Voltage (Volts)
 R_{\max} = Maximum Loop Resistance (Ohms)

NOTE

HART Communication requires a minimum loop resistance of 250 ohms.

Rosemount 8700 Series

Supply Current Requirements (8712D)

Units powered by 12-42 V DC power supply may draw up to 1 amp of current steady state.

FIGURE 4. DC Current Requirements

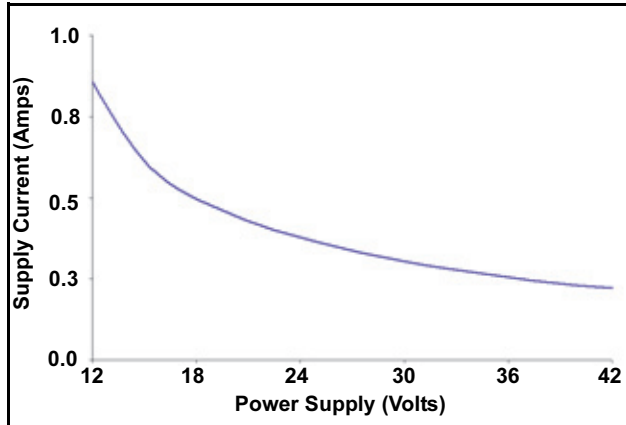

Installation Coordination

Installation (overvoltage) Category II

Power Consumption

8712D: 10 watts maximum

8712H: 300 watts maximum

Ambient Temperature Limits

Operating

8712D: -20 to 140°F (-29 to 60 °C) with local operator interface

-40 to 165°F (-40 to 74°C) without local operator interface

8712H: -20 to 130 °F (-29 to 54 °C) with or without local operator interface

Storage

-40 to 176 °F (-40 to 80 °C)

Humidity Limits

0–100% RH at 120 °F (49 °C), decreases linearly to 10% RH at 130 °F (54 °C)

Enclosure Ratings

Enclosure Type NEMA 4X, IP66

Output Signals

Analog Output Adjustment

4–20 mA, switch-selectable as internally or externally powered 5 to 24 V DC; 0 to 1000 Ω load.

Engineering units—lower and upper range values are user-selectable.

Output automatically scaled to provide 4 mA at lower range value and 20 mA at upper range value.

8712D:

Full scale continuously adjustable between -39 and 39 ft/s (-12 to 12 m/sec), 1 ft/s (0.3 m/s) minimum span.

8712H:

Full scale continuously adjustable between -30 and 30 ft/s (-10 to 10 m/sec), 1 ft/s (0.3 m/s) minimum span.

HART Communications, digital flow signal, superimposed on 4–20 mA signal, available for control system interface. 250 Ω required for HART communications.

Scalable Frequency Adjustment

8712D:

0-10,000Hz, externally powered at 5 to 24 V DC, transistor switch closure supports power loads up to 2W for frequencies up to 4000Hz, and 5 V DC at 0.1 W at maximum frequency of 10,000 Hz.

Pulse can be set to equal desired velocity or volume in user selectable engineering units.

Pulse width is adjustable from 1.5 to 500 msec, below 1.5 msec pulse width automatically switches to 50% duty cycle.

8712H:

0-1000 Hz, externally powered at 5 to 24 V DC, transistor switch closure up to 5.75 W. Pulse value can be set to equal desired volume in selected engineering units. Pulse width adjustable from 0.5 to 100 m/s. Local operator interface automatically calculates and displays maximum allowable output frequency.

Auxiliary Output Function

Externally powered at 5 to 24 V DC, transistor switch closure up to 3 W to indicate either:

Reverse Flow:

Activates switch closure output when reverse flow is detected. The reverse flow rate is displayed.

Zero Flow:

Activates switch closure output when flow goes to 0 ft/s.

Product Data Sheet

00813-0100-4727, Rev RA
December 2007

Rosemount 8700 Series

Positive Zero Return (PZR)⁽¹⁾

Forces outputs of the transmitter to the zero flow rate signal level. Activated by applying a contact closure.

Security Lockout

Security lockout jumper on the electronics board can be set to deactivate all LOI and HART-based communicator functions to protect configuration variables from unwanted or accidental change.

Output Testing

Analog Output Test

Transmitter may be commanded to supply a specified current between 3.75 and 23.25 mA

Pulse Output Test

8712D:

Transmitter may be commanded to supply a specified frequency between 1 pulse/ day and 10,000 Hz

8712H:

Transmitter may be commanded to supply a specified frequency between 1 and 1000 Hz

Turn-on Time

8712D:

5 minutes to rated accuracy from power up, 5 seconds from power interruption

8712H:

30 minutes to rated accuracy from power up, 5 seconds from power interruption

Start-up Time

0.2 seconds from zero flow

Low Flow Cutoff

Adjustable between 0.01 and 38.37 ft/s (0.003 and 11.7 m/s). Below selected value, output is driven to the zero flow rate signal level.

Overrange Capability

Signal output will remain linear until 110% of upper range value. The signal output will remain constant above these values. Out of range message displayed on LOI and the HART Communicator.

Damping

8712D:

Adjustable between 0.0 and 256 seconds

8712H:

Adjustable between 0.2 and 256 seconds

Flowtube Sensor Compensation

Rosemount flowtube sensors are flow-calibrated and assigned a calibration factor at the factory. The calibration factor is entered into the transmitter, enabling interchangeability of flowtube sensors without calculations or a compromise in accuracy.

8712D transmitters and other manufacturer's flowtube sensors can be calibrated at known process conditions or at the Rosemount NIST-Traceable Flow Facility. Transmitters calibrated on site require a two-step procedure to match a known flow rate. This procedure can be found in the Operations Manual 00809-0100-4661.

(1) PZR is internally powered on the 8712H transmitter.

Rosemount 8700 Series

Performance Specifications

(System specifications are given using the frequency output and with the unit at referenced conditions.)

Accuracy

Includes the combined effects of linearity, hysteresis, repeatability, and calibration uncertainty.

Rosemount 8712D with 8705/8707 Flowtube Sensor:

Standard system accuracy is $\pm 0.25\%$ of rate ± 1.0 mm/sec from 0.04 to 6 ft/s (0.01 to 2 m/s); above 6 ft/s (2 m/s), the system has an accuracy of $\pm 0.25\%$ of rate ± 1.5 mm/sec.

Optional high accuracy is $\pm 0.15\%$ of rate ± 1.0 mm/sec from 0.04 to 13 ft/s (0.01 to 4 m/s); above 13 ft/s (4 m/s), the system has an accuracy of $\pm 0.18\%$ of rate.⁽¹⁾

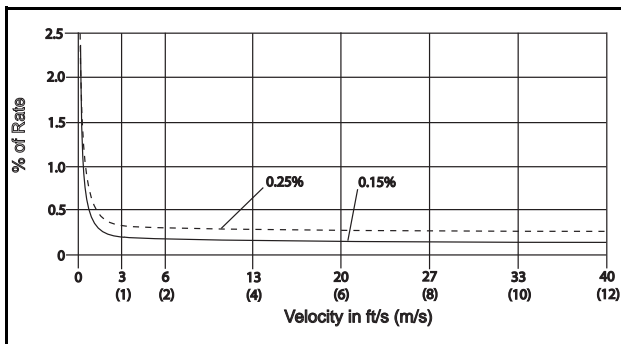

Rosemount 8712D with 8711 Flowtube Sensor:

Standard system accuracy is $\pm 0.25\%$ of rate ± 2.0 mm/sec from 0.04 to 39 ft/s (0.01 to 12 m/s).

Optional high accuracy is $\pm 0.15\%$ of rate ± 1.0 mm/sec from 0.04 to 13 ft/s (0.01 to 4 m/s); above 13 ft/s (4 m/s), the system has an accuracy of $\pm 0.18\%$ of rate.

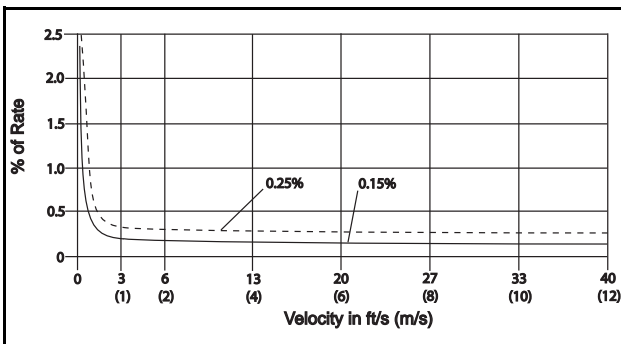

Rosemount 8712D with 8721 Flowtube Sensor:

Standard system accuracy is $\pm 0.5\%$ of rate from 1 to 39 ft/s (0.3 to 12 m/s); between 0.04 and 1.0 ft/s (0.01 and 0.3 m/s), the system has an accuracy of ± 0.005 ft/s (0.0015 m/s).

Optional high accuracy is $\pm 0.25\%$ of rate from 3 to 39 ft/s (1 to 12 m/s).

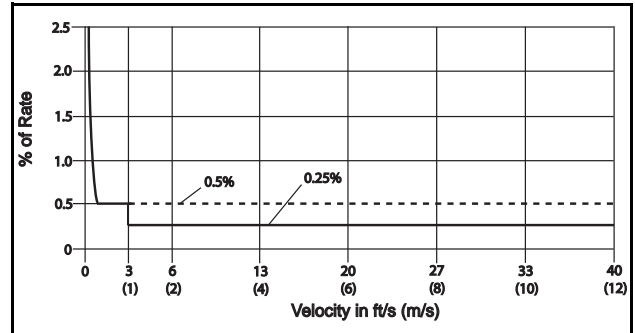

Rosemount 8712D with Legacy 8705 Flowtube Sensors:

Standard system accuracy is $\pm 0.5\%$ of rate from 1 to 39 ft/s (0.3 to 12 m/s); between 0.04 and 1.0 ft/s (0.01 and 0.3 m/s), the system has an accuracy of ± 0.005 ft/s (0.0015 m/s).

Rosemount 8712D with Legacy 8711 Flowtube Sensors:

Standard system accuracy is $\pm 0.5\%$ of rate from 3 to 39 ft/s (1 to 12 m/s); between 0.04 and 3.0 ft/s (0.01 and 1 m/s), the system has an accuracy of ± 0.015 ft/s (0.005 m/s).

Rosemount 8712D with Other Manufacturers' Flowtube Sensors:

When calibrated in the Rosemount Flow Facility, system accuracies as good as 0.5% of rate can be attained.

There is no accuracy specification for other manufacturers' flowtube sensors calibrated in the process line.

(1) For Flowtube Sensor sizes greater than 12 in. (300 mm) the high accuracy is $\pm 0.25\%$ of rate from 3 to 40 ft/sec (1 to 12 m/sec).

Product Data Sheet

00813-0100-4727, Rev RA

December 2007

Rosemount 8700 Series

Rosemount 8712H with 8707 Flowtube Sensor

System accuracy is $\pm 0.5\%$ of rate from 3 to 30 ft/s (1 to 10 m/s); between 0.04 and 3.0 ft/s (0.01 and 0.3 m/s), the system has an accuracy of ± 0.015 ft/s (0.005 m/s).

Optional high accuracy is $\pm 0.25\%$ of rate from 3 to 30 ft/s (1 to 10 m/s).

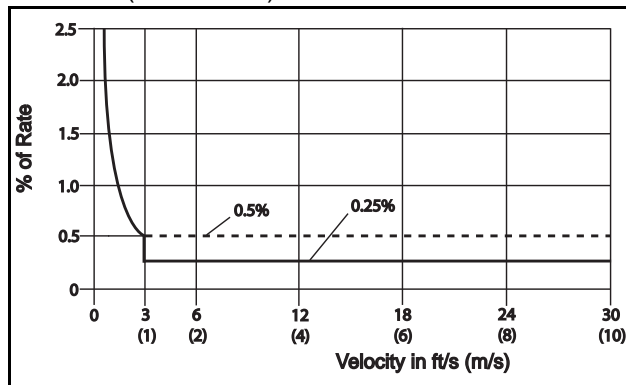

Analog Output Effect

8712D:

Analog output has the same accuracy as frequency output plus an additional 0.05% of span.

8712H:

Analog output has the same accuracy as frequency output plus an additional 0.1% of span.

Vibration Effect

$\pm 0.1\%$ of span per SAMA PMC 31.1, Level 2

Repeatability

$\pm 0.1\%$ of reading

Response Time

0.2 seconds maximum response to step change in input

Stability

$\pm 0.1\%$ of rate over six months

Ambient Temperature Effect

8712D:

0.25% over operating temperature range

8712H:

$\pm 1\%$ per 100 °F (37.8 °C)

EMC Compliance

EN61326-1 1997 + A1/A2/A3 (Industrial) electromagnetic compatibility (EMC) for process and laboratory apparatus.

Physical Specifications

Materials of Construction

Housing

Low-copper aluminum, NEMA 4X and IEC 60529 IP65

Pollution Degree 2

Paint

Polyurethane

Cover Gasket

Rubber

Electrical Connections

Four $\frac{1}{2}$ -14 NPT connections provided on the base of the transmitter. Screw terminals provided for all of the connections. Power wiring connected to the transmitter only. Remote mounted transmitters require only a single conduit connection to the flowtube sensor.

NOTE

If $\frac{3}{4}$ -14 NPT connections are required, $\frac{1}{2}$ to $\frac{3}{4}$ in. adapter kits are available for order.

Line Power Fuses

90–250 V AC systems (8712D)

2 amp, Quick-acting Bussman AGCI or equivalent

12–42 V DC systems (8712D)

3 amp, Quick-acting Bussman AGCI or equivalent

115 V AC systems (8712H)

5 amp, Quick-acting Bussman AGCI or equivalent (Rosemount 8712H only).

Transmitter Weight

Transmitter approximately 9 lb (4 kg). Add 1 lb (0.5 kg) for local operator interface.

Rosemount 8700 Series



Rosemount 8742C Transmitter Specifications

Functional Specifications

Flowtube Sensor Compatibility

Compatible with Rosemount 8705, 8711, 8721, and 570TM flowtube sensors.

Compatible with Rosemount 8707 flowtube sensor with D2 Dual Calibration Option.

Conductivity Limits

Process liquid must have a conductivity of 5 microsiemens/cm (5 micromhos/cm) or greater for 8742C. Excludes the effects of interconnecting cable length in remote mount transmitter installations.

Flowtube Sensor Coil Resistance

25 Ω maximum

Flow Rate Range

Capable of processing signals from fluids that are traveling between 0 and 39 ft/s (0 to 12 m/s) for both forward and reverse flow in all flowtube sensor sizes.

Power Supply

90–250 V AC, 50–60 Hz, 15–50 V DC

Supply Current Requirements

Units powered by 15-50 V DC power supply may draw up to 1 amp of current.

FIGURE 5. DC Current Requirements

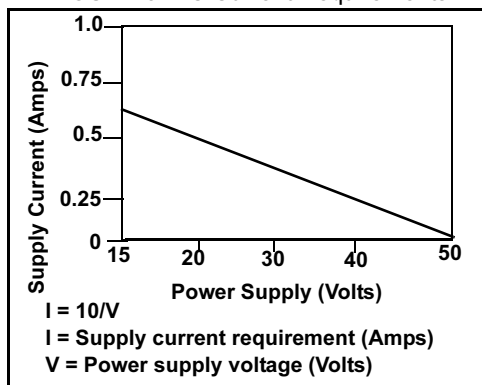

Installation Coordination

Installation (overvoltage) Category II

Power Consumption

10 watts maximum

Ambient Temperature Limits

Operating

–40 to 165 °F (–40 to 74 °C) without local display
–13 to 147 °F (–25 to 65 °C) with local display

Storage

–40 to 185 °F (–40 to 85 °C)

Humidity Limits

0–100% RH to 150 °F (65 °C)

Enclosure Rating

NEMA 4X CSA Type 4X, IEC 60529, IP66 (transmitter), Pollution Degree 2

Output Signal

Manchester-encoded digital signal that conforms to IEC 1158-2 and ISA 50.02

FOUNDATION fieldbus Specifications

Schedule Entries

Seven (7)

Links

Twenty (20)

Virtual Communications Relationships (VCRs)

One (1) predefined (F6, F7) Nineteen (19) configurable (see Table 1)

TABLE 3. Block Information

Block	Execution Time (Milliseconds)
Resource (RB)	—
Transducer (TB)	—
Analog Input (AI)	15
Proportional/Integral/Derivative (PID)	25
Integrator (INT)	20
Arithmetic (AR)	20

Reverse Flow

Detects and reports reverse flow

Software Lockout

A write-lock switch and software lockout are provided in the resource function block.

Turn-on Time

30 minutes to rated accuracy from power up; 10 seconds communication from power interruption

Start-up Time

0.2 seconds from zero flow

Low Flow Cutoff

Adjustable between 0 and 1 ft/s. Below selected value, output is driven to the zero flow rate.

Overrange Capability

Signal output continues to 110% of upper range value setting, then remains constant. Messages are supplied to the fieldbus network.

Damping

Adjustable between 0 and 255 seconds

Performance Specifications

(System specifications are given using the unit at referenced conditions.)

Accuracy

Includes the combined effects of linearity, hysteresis, repeatability, and calibration uncertainty.

Rosemount 8742C with 8705/8707 Flowtube Sensor:

Standard system accuracy is $\pm 0.3\%$ of rate ± 1.0 mm/sec from 0.04 to 39 ft/s (0.01 to 12 m/s).

Optional high accuracy is $\pm 0.2\%$ of rate ± 1.0 mm/sec from 0.04 to 39 ft/s (0.01 to 12 m/s)⁽¹⁾.

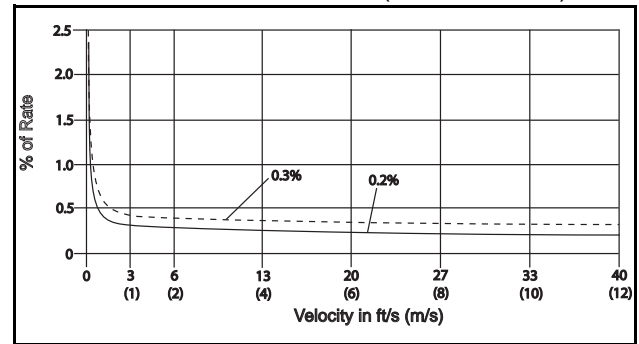

Rosemount 8742C with 8711 Flowtube Sensor:

Standard system accuracy is $\pm 0.3\%$ of rate ± 2.0 mm/sec from 0.04 to 39 ft/s (0.01 to 12 m/s).

Optional high accuracy is $\pm 0.2\%$ of rate ± 1.0 mm/sec from 0.04 to 39 ft/s (0.01 to 12 m/s).

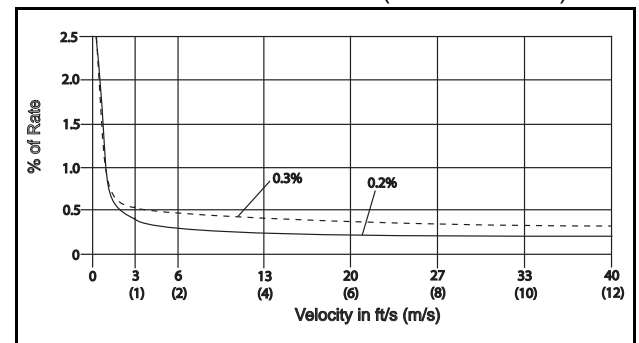

(1) For Flowtube Sensor sizes greater than 12 in. (300 mm) the high accuracy is $\pm 0.25\%$ of rate from 3 to 40 ft/sec (1 to 12 m/sec).

Rosemount 8700 Series

Rosemount 8742C with 8721 Flowtube Sensor:

Standard system accuracy is $\pm 0.5\%$ of rate from 1 to 39 ft/s (0.3 to 12 m/s); between 0.04 and 1.0 ft/s (0.01 and 0.3 m/s), the system has an accuracy of ± 0.005 ft/s (0.0015 m/s).

Optional high accuracy is $\pm 0.25\%$ of rate from 3 to 39 ft/s (1 to 12 m/s).

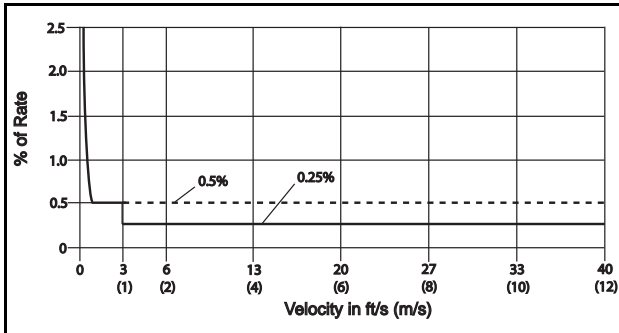

Rosemount 8742C with Legacy 8705 Flowtube Sensors:

Standard system accuracy is $\pm 0.5\%$ of rate from 1 to 39 ft/s (0.3 to 12 m/s); between 0.04 and 1.0 ft/s (0.01 and 0.3 m/s), the system has an accuracy of ± 0.005 ft/s (0.0015 m/s).

Rosemount 8742C with Legacy 8711 Flowtube Sensors:

Standard system accuracy is $\pm 0.5\%$ of rate from 3 to 39 ft/s (1 to 12 m/s); between 0.04 and 3.0 ft/s (0.01 and 1 m/s), the system has an accuracy of ± 0.015 ft/s (0.005 m/s).

Vibration Effect

IEC 60770-1

Repeatability

$\pm 0.1\%$ of reading

Response Time

0.2 seconds maximum response to step change in input

Stability

$\pm 0.1\%$ of rate over six months

Ambient Temperature Effect

$\pm 0.25\%$ of rate over operating temperature range

EMC Compliance

EN61326-1 1997 + A1/A2/A3 (Industrial) electromagnetic compatibility (EMC) for process and laboratory apparatus.

Transient Protection

The 8742C transmitter prevents damage to the flowmeter from transients compliant to:

IEC 61000 – 4-4 (for burst currents)

IEC 61000 – 4-5 (for surge currents)

Mounting Position Effect

None when installed to ensure flowtube sensor remains full

Physical Specifications

Materials of Construction (Transmitter)

Housing

Low-copper aluminum

Paint

Polyurethane

Cover Gasket

Rubber

Electrical Connections

Two $\frac{3}{4}$ –14 NPT with number 8 screw terminal connections are provided for electrical wiring. PG13.5 and CM20 adapters are available. Screw terminals provided for all connections. Power wiring connected to transmitter only. Integrally mounted transmitters are factory wired to the flowtube sensor.

Mounting

Integrally mounted transmitters do not require interconnecting cables. The local display and transmitter can be rotated in 90° increments. Remote mounted transmitters require only a single conduit connection to the flowtube sensor.

Weight

Approximately 7 pounds (3.2 kg). Add 0.5 pounds (0.5 kg) for local display.



Rosemount 8705 Flanged and 8707 High-Signal Flanged Flowtube Sensors Specifications

Functional Specifications

Service

Conductive liquids and slurries

Line Sizes

1/2–36 in. (15–900 mm) for Rosemount 8705

3–36 in. (80–600 mm) for Rosemount 8707

Interchangeability

Rosemount 8705 Flowtube Sensors are interchangeable with 8712D, 8732, and 8742C Transmitters. Rosemount 8707 High-Signal Flowtube Sensors are interchangeable with 8712H High-Signal Transmitters. System accuracy is maintained regardless of line size or optional features. Each flowtube sensor nameplate has a sixteen-digit calibration number that can be entered into a transmitter through the Local Operator Interface (LOI) or the HART Communicator on the 8712D and the 8732E. In a FOUNDATION fieldbus environment, the 8742C can be configured using the DeltaV™ fieldbus configuration tool or another FOUNDATION fieldbus configuration device. No further calibration is necessary.

Upper Range Limit

39 ft/s (12 m/s)

Process Temperature Limits

PTFE Lining

–20 to 350 °F (–29 to 177 °C)

ETFE Lining

–20 to 300 °F (–29 to 149 °C)

PFA Lining

–20 to 350 °F (–29 to 177 °C)

Polyurethane Lining

0 to 140 °F (–18 to 60 °C)

Neoprene Lining

0 to 185 °F (–18 to 85 °C)

Linatex Lining

0 to 158 °F (–18 to 70 °C)

Ambient Temperature Limits

–30 to 150 °F (–34 to 65 °C)

Pressure Limits

See Table 4 and Table 6

Vacuum Limits

PTFE Lining

Full vacuum to 350 °F (177 °C) through 4-in. (100 mm) line sizes. Consult factory for vacuum applications with line sizes of 6 inches (150 mm) or larger.

All Other Standard Flowtube Sensor Lining Materials

Full vacuum to maximum material temperature limits for all available line sizes.

Submergence Protection

IP68. Continuous submergence to 30 ft. (10 m). Requires conduit entries of the flowtube sensor remote junction box be properly sealed to prevent water ingress. This requires the user to install sealed IP68 approved cable glands, conduit connections, or conduit plugs.

Conductivity Limits

Process liquid must have a conductivity of 5 microsiemens/cm (5 micromhos/cm) or greater for 8705. Process liquid must have a conductivity of 50 microsiemens/cm (50 micromhos/cm) for 8707 when used with 8712H, 5 microsiemens/cm when used with other transmitters. Excludes the effect of interconnecting cable length in remote mount transmitter installations.

Rosemount 8700 Series

TABLE 4. Temperature vs. Pressure Limits⁽¹⁾

Flowtube Sensor Temperature vs. Pressure Limits for ASME B16.5 Class Flanges (1/2- to 36-in. line sizes) ⁽²⁾					
Flange Material	Flange Rating	Pressure			
		@ -20 to 100 °F (-29 to 38 °C)	@ 200 °F (93 °C)	@ 300 °F (149 °C)	@ 350 °F (177 °C)
Carbon Steel	Class 150	285 psi	260 psi	230 psi	215 psi
	Class 300	740 psi	675 psi	655 psi	645 psi
	Class 600 ⁽³⁾	1000 psi	800 psi	700 psi	650 psi
	Class 600 ⁽⁴⁾	1480 psi	NA	NA	NA
	Class 900	2220 psi			
304 Stainless Steel	Class 150	275 psi	235 psi	205 psi	190 psi
	Class 300	720 psi	600 psi	530 psi	500 psi
	Class 600 ⁽⁵⁾	1000 psi	800 psi	700 psi	650 psi
	Class 600 ⁽⁶⁾	1440 psi	NA	NA	NA
	Class 900	2160 psi			

- (1) Liner temperature limits must also be considered. Polyurethane, Linatex, and Neoprene have temperature limits of 140 °F (60 °C), 158 °F (70 °C), and 185 °F (85 °C), respectively.
- (2) 30- and 36-in. AWWA C207 Table 5 Class D rated to 150 psi at atmospheric temperature.
- (3) Option Code C6
- (4) Option Code C7
- (5) Option Code S6
- (6) Option Code S7

TABLE 5. Temperature vs. Pressure Limits⁽¹⁾

Flowtube Sensor Temperature vs. Pressure Limits for AS2129 Table D and E Flanges (4- to 24-in. line sizes)					
Flange Material	Flange Rating	Pressure			
		@ -200 to 50 °F (-320 to 122 °C)	@ 100 °F (212 °C)	@ 150 °F (302 °C)	@ 200 °F (392 °C)
Carbon Steel	D	101.6 psi	101.6 psi	101.6 psi	94.3 psi
	E	203.1 psi	203.1 psi	203.1 psi	188.6 psi

- (1) Liner temperature limits must also be considered. Polyurethane, Linatex, and Neoprene have temperature limits of 140 °F (60 °C), 158 °F (70 °C), and 185 °F (85 °C), respectively.

TABLE 6. Temperature vs. Pressure Limits⁽¹⁾

Flowtube Sensor Temperature vs. Pressure Limits for DIN Flanges (15 to 600 mm line sizes)					
Flange Material	Flange Rating	Pressure			
		@ -196 to 50 °C (-320 to 122 °F)	@ 100 °C (212 °F)	@ 150 °C (302 °F)	@ 175 °C (347 °F)
Carbon Steel	PN 10	10 bar	10 bar	9.7 bar	9.5 bar
	PN 16	16 bar	16 bar	15.6 bar	15.3 bar
	PN 25	25 bar	25 bar	24.4 bar	24.0 bar
	PN 40	40 bar	40 bar	39.1 bar	38.5 bar
304 Stainless Steel	PN 10	9.1 bar	7.5 bar	6.8 bar	6.5 bar
	PN 16	14.7 bar	12.1 bar	11.0 bar	10.6 bar
	PN 25	23 bar	18.9 bar	17.2 bar	16.6 bar
	PN 40	36.8 bar	30.3 bar	27.5 bar	26.5 bar

- (1) Liner temperature limits must also be considered. Polyurethane, Linatex, and Neoprene have temperature limits of 140 °F, 158 °F, and 185 °F, respectively.

Product Data Sheet

00813-0100-4727, Rev RA

December 2007

Rosemount 8700 Series

Performance Specifications

(System specifications are given using the frequency output and with the unit at referenced conditions.)

Accuracy

Includes the combined effects of linearity, hysteresis, repeatability, and calibration uncertainty.

Rosemount 8705/8707 with 8732E and 8712D:

Standard system accuracy is $\pm 0.25\%$ of rate ± 1.0 mm/sec from 0.04 to 6 ft/s (0.01 to 2 m/s); above 6 ft/s (2 m/s), the system has an accuracy of $\pm 0.25\%$ of rate ± 1.5 mm/sec.

Optional high accuracy is $\pm 0.15\%$ of rate ± 1.0 mm/sec from 0.04 to 13 ft/s (0.01 to 4 m/s); above 13 ft/s (4 m/s), the system has an accuracy of $\pm 0.18\%$ of rate.⁽¹⁾

Rosemount 8742C with 8705/8707 Flowtube Sensor:

Standard system accuracy is $\pm 0.3\%$ of rate ± 1.0 mm/sec from 0.04 to 39 ft/s (0.01 to 12 m/s).

Optional high accuracy is $\pm 0.2\%$ of rate ± 1.0 mm/sec from 0.04 to 39 ft/s (0.01 to 12 m/s)⁽¹⁾.

Rosemount 8707 with 8712H:

System accuracy is $\pm 0.5\%$ of rate from 3 to 30 ft/s (1 to 10 m/s); between 0.04 and 3.0 ft/s (0.01 and 0.3 m/s), the system has an accuracy of ± 0.005 ft/s (0.0015 m/s).

Vibration Effect

IEC 60770-1

Mounting Position Effect

None when installed to ensure flowtube sensor remains full

Physical Specifications

Non-Wetted Materials

Flowtube Sensor

AISI Type 304 SST (optional 316L SST)

Flanges

Carbon steel, AISI Type 304/304L SST, or Type 316/316L SST

Housing

Welded steel

Paint

Polyurethane

Process Wetted Materials

Lining

PFA, PTFE, ETFE, polyurethane, neoprene, Linatex

Electrodes

316L SST, Nickel Alloy 276 (UNS N10276), tantalum, 80% platinum-20% iridium, titanium

Process Connections

ASME B16.5 (ANSI) Class 150, Class 300, Class 600, or Class 900

0.5- to 30-in. (Class 150)

0.5- to 24-in. (Class 300)

0.5- to 10-in. (Class 600 derated to 1000 psi max)

1- to 8-in. (Full rated Class 600 and 900)

AWWA C207 Table 3 Class D

30 and 36 in.

EN 1092 (DIN) PN 10, 16, 25, and 40

PN10: Not available for flange sizes from 15 to 150 mm

PN16: Not available for flange sizes from 15 to 80 mm

PN 25: Not available for flange sizes from 15 to 150 mm

PN40: Available for all flange sizes

AS 2129 Table D and E

0.5 to 36 in.

Electrical Connections

Two $1/2$ -14 NPT connections with number 8 screw terminals are provided in the terminal enclosure for electrical wiring.

⁽¹⁾ For Flowtube Sensor sizes greater than 12 in. (300 mm) the high accuracy is $\pm 0.25\%$ of rate from 3 to 40 ft/sec (1 to 12 m/sec).

Rosemount 8700 Series

Grounding Electrode

An optional grounding electrode can be installed similarly to the measurement electrodes through the flowtube sensor lining on 8705 flowtube sensors. It is available in all electrode materials.

Grounding Rings

Optional grounding rings can be installed between the flange and the tube face on both ends of the flowtube sensor. Single ground rings can be installed on either end of the flowtube sensor. They have an I.D. slightly smaller than the flowtube sensor I.D. and an external tab to attach ground wiring. Grounding rings are available in 316L SST, Nickel Alloy 276 (UNS N10276), titanium, and tantalum.

Lining Protectors

Optional lining protectors can be installed between the flange and the tube face on both ends of the flowtube sensor. The leading edge of lining material is protected by the lining protector; lining protectors cannot be removed once they are installed. Lining protectors are available in 316L SST, Nickel Alloy 276 (UNS N10276), and titanium.

Dimensions

See Figure 9, Figure 10, and Figure 12 and Table 16, Table 19, and Table 20.

Weight

See Table 7 and Table 8

TABLE 7. Flowtube Sensor Weight (ASME)

Nominal Line Size ⁽¹⁾ Inches (mm)	Flowtube Sensor Flange Rating		Flowtube Sensor Weight lb (kg)
	ASME B16.5 (ANSI)	EN 1092-1 (DIN)	
½ (15)	150	PN 40	20 (9)
½ (15)	300		22 (10)
1 (25)	150	PN 40	20 (9)
1 (25)	300		22 (10)
1½ (40)	150	PN 40	22 (10)
1½ (40)	300		24 (11)
2 (50)	150	PN 40	26 (12)
2 (50)	300		28 (13)
3 (80)	150	PN 40	40 (18)
3 (80)	300		47 (21)
4 (100)	150	PN 16	48 (22)
4 (100)	300		65 (30)
6 (150)	150	PN 16	81 (37)
6 (150)	300		93 (42)
8 (200)	150	PN 10	110 (50)
8 (200)	300		162 (74)
10 (250)	150	PN 10	220 (98)
10 (250)	300		300 (136)
12 (300)	150	PN 10	330 (150)
12 (300)	300		435 (197)
14 (350)	150	PN 10	370 (168)
16 (400)	150	PN 10	500 (227)
18 (450)	150	PN 10	600 (272)
20 (500)	150	PN 10	680 (308)
24 (600)	150	PN 10	1,000 (454)
30 (750)	125	-	1,747 (792)
36 (900)	125	-	1,975 (898)

(1) 30- and 36-in. AWWA C207 Table 2 Class D rated to 150 psi at atmospheric temperature.

TABLE 8. Flowtube Sensor weights (AS2129)

Nominal Line Size Inches (mm)	AS2129	Flowtube Sensor Weight lb (kg)
4 (100)	D	33 (15)
4 (100)	E	37 (17)
6 (150)	D	66 (30)
6 (150)	E	71 (32)
8 (200)	D	86 (39)
8 (200)	E	88 (40)
10 (250)	D	187 (85)
10 (250)	E	201 (91)
12 (300)	D	273 (124)
12 (300)	E	284 (129)
14 (350)	D	293 (133)
14 (350)	E	317 (144)
16 (400)	D	386 (175)
16 (400)	E	430 (195)
18 (450)	D	516 (234)
18 (450)	E	569 (258)
20 (500)	D	569 (258)
20 (500)	E	626 (284)
24 (600)	D	855 (388)
24 (600)	E	974 (442)

Rosemount 8700 Series



Rosemount 8711 Wafer Flowtube Sensor Specifications

SPECIFICATIONS

Functional Specifications

Service

Conductive liquids and slurries

Line Sizes

0.15 in. through 8 in. (4 through 200 mm)

Interchangeability

Rosemount 8711 Flowtube Sensors are interchangeable with 8732E, 8712D and 8742C Transmitters. System accuracy is maintained regardless of line size or optional features. Each flowtube sensor nameplate has a sixteen-digit calibration number that can be entered into a transmitter through the Local Operator Interface (LOI) or the HART Communicator on the Rosemount 8712D and the 8732E. In a FOUNDATION fieldbus environment, the 8742C can be configured using the DeltaV fieldbus configuration tool or another FOUNDATION fieldbus configuration device. No further calibration is necessary.

Upper Range Limit

39 ft/s (12 m/s)

Process Temperature Limits

ETFE Lining

-20 to 300 °F (-29 to 149 °C) for 0.5- through 8-in. (15–200 mm) line sizes

PTFE Lining

-20 to 350 °F (-29 to 177 °C)

PFA Lining

-20 to 200 °F (-29 to 93 °C)

Ambient Temperature Limits

-30 to 150 °F (-34 to 65 °C)

Maximum Safe Working Pressure at 100 °F (38 °C)

ETFE Lining

Full vacuum to 740 psi (5.1 MPa) for 0.5- through 8-in. (15 through 200 mm) flowtube sensors

PTFE Lining

Full vacuum through 4-in. (100 mm) line sizes. Consult factory for vacuum applications with line sizes of 6 inches (150 mm) or larger.

PFA Lining

Full vacuum to 285 psi (1.96 MPa) for 0.15- and 0.30-in. (4 and 8 mm) flowtube sensors

Conductivity Limits

Process liquid must have a conductivity of 5 microsiemens/cm (5 micromhos/cm) or greater for 8711. Excludes the effect of interconnecting cable length in remote mount transmitter installations.

Performance Specifications

(System specifications are given using the frequency output and with the unit at referenced conditions.)

Accuracy

Rosemount 8711 with 8732E and 8712D:

Standard system accuracy is $\pm 0.25\%$ of rate ± 2.0 mm/sec from 0.04 to 39 ft/s (0.01 to 12 m/s).

Optional high accuracy is $\pm 0.15\%$ of rate ± 1.0 mm/sec from 0.04 to 13 ft/s (0.01 to 4 m/s); above 13 ft/s (4 m/s), the system has an accuracy of $\pm 0.18\%$ of rate.

Rosemount 8742C with 8711 Flowtube Sensor:

Standard system accuracy is $\pm 0.3\%$ of rate ± 2.0 mm/sec from 0.04 to 39 ft/s (0.01 to 12 m/s).

Optional high accuracy is $\pm 0.2\%$ of rate ± 1.0 mm/sec from 0.04 to 39 ft/s (0.01 to 12 m/s).

Vibration Effect

IEC 60770-1

Product Data Sheet

00813-0100-4727, Rev RA

December 2007

Rosemount 8700 Series

Mounting Position Effect

No effect when installed to ensure flowtube sensor remains full

Physical Specifications

Non-Wetted Materials

Flowtube Sensor

303 SST (ASTM A-743)

Coil Housing

Investment cast steel (ASTM A-27)

Paint

Polyurethane

Process-Wetted Materials

Lining

ETFE, PTFE and PFA

Electrodes

316L SST, Nickel Alloy 276 (UNS N10276), tantalum, 80% platinum—20% iridium, titanium

Process Connections

Mounts between these Flange Configurations

ASME B16.5 (ANSI): Class 150, 300

EN 1092 (DIN): PN 10 and 25

BS: 10 Table D, E, and F

Studs, Nuts, and Washers⁽¹⁾

ASME B16.5 (ANSI)

0.15- through 1-in. (4 through 25 mm):
316 SST, ASTM A193, Grade B8M, Class 1 threaded mounting studs; ASTM A194, Grade 8M heavy hex nuts; SAE per ANSI B18.2.1, Type A, Series N flat washers.

1.5- through 8-in. (40 through 200 mm):
CS, ASTM A193, Grade B7, Class 1 threaded mounting studs; ASTM A194, Grade 2H heavy hex nuts; SAE per ANSI B18.2.1, Type A, Series N flat washers; all items clear, chromate zinc-plated.

EN 1092 (DIN)

4 through 25 mm (0.15- through 1-in.):
316 SST ASTM A193, Grade B8M Class 1 threaded mounting studs; ASTM A194, Grade 8M, DIN 934 H=D, metric heavy hex nuts; 316 SST, A4, DIN 125 flat washers.

40 through 200 mm (1.5- through 8-in.):
CS, ASTM A193, Grade B7 threaded mounting studs; ASTM A194, Grade 2H, DIN 934 H=D, metric heavy hex nuts; CS, DIN 125 flat washers; all items yellow zinc-plated.

Electrical Connections

Two 1/2–14 NPT connections with number 8 screw terminals are provided in the terminal enclosure for electrical wiring.

Grounding Electrode

An optional grounding electrode can be installed similarly to the measurement electrodes through the flowtube sensor lining. It is available in all electrode materials.

Grounding Rings

Optional grounding rings can be installed between the flange and the tube face on both ends of the flowtube sensor. They have an I.D. slightly smaller than the flowtube sensor I.D. and an external tab to attach ground wiring. Grounding rings are available in 316L SST, Nickel Alloy 276 (UNS N10276), titanium, and tantalum.

Dimensions and Weight

See Figure 11, Figure 12, and Table 21

(1) 0.15 and 0.30 in. (4 and 80 mm) flowtube sensors mount between 1/2-in. flange.

Rosemount 8700 Series



Rosemount 8721 Sanitary Flowtube Sensor Specifications

Functional Specifications

Service

Conductive liquids and slurries

Line Sizes

1/2 - 4 in. (15–100 mm)

Flowtube Sensor Compatibility and Interchangeability

The Rosemount 8721 Flowtube Sensors are interchangeable with Rosemount 8732, 8742, and 8712D transmitters. System accuracy is maintained regardless of line size or optional features.

Each flowtube sensor nameplate has a sixteen-digit calibration number that can be entered into the transmitter through the Local Operator Interface (LOI) or the HART Communicator. No further calibration is necessary.

Flowtube Sensor Compensation

Rosemount flowtube sensors are flow-calibrated and assigned a calibration factor at the factory. The calibration factor is entered into the transmitter, enabling interchangeability of flowtube sensors without calculations or a compromise in accuracy.

Conductivity Limits

Process liquid must have a conductivity of 5 microsiemens/cm (5 micromhos/cm) or greater. Excludes the effect of interconnecting cable length in remote mount transmitter installations.

Flowtube Sensor Coil Resistance

5Ω to 10Ω (line size dependent)

Flow Rate Range

Capable of processing signals from fluids that are traveling between 0.04 and 39 ft/s (0.01 to 12 m/s) for both forward and reverse flow in all flowtube sensor sizes. Full scale continuously adjustable between -39 and 39 ft/s (-12 to 12 m/s).

Flowtube Sensor Ambient Temperature Limits

14 to 140 °F (-15 to 60 °C)

Process Temperature Limits

PFA Lining

-20 to 350 °F (-29 to 177 °C)

Pressure Limits

Line Size	Max Working Pressure	CE Mark Max. Working Pressure
1/2 (15)	300 psi (20.7 bar)	300 psi (20.7 bar)
1 (25)	300 psi (20.7 bar)	300 psi (20.7 bar)
1 1/2 (40)	300 psi (20.7 bar)	300 psi (20.7 bar)
2 (50)	300 psi (20.7 bar)	300 psi (20.7 bar)
2 1/2 (65)	300 psi (20.7 bar)	240 psi (16.5 bar)
3 (80)	300 psi (20.7 bar)	198 psi (13.7 bar)
4 (100)	210 psi (14.5 bar)	148 psi (10.2 bar)

Vacuum Limits

Full vacuum at maximum lining material temperature; consult factory.

Submergence Protection (Flowtube Sensor)

IP68. Continuous submergence to 30 ft. (10 m). Requires conduit entries of the flowtube sensor remote junction box be properly sealed to prevent water ingress. This requires the use of sealed IP68 approved cable glands, conduit connections, or conduit plugs.

Performance Specifications

(System specifications are given using the frequency output and with the unit at referenced conditions).

Accuracy

Rosemount 8732, 8742, or 8712D with 8721 Flowtube Sensor

System accuracy is ±0.5% of rate from 1 to 39 ft/s (0.3 to 12 m/s); includes combined effects of linearity, hysteresis, repeatability, and calibration uncertainty; between 0.04 and 1.0 ft/s (0.01 and 0.5 m/s), the system has an accuracy of ±0.005 ft/s.

Product Data Sheet

00813-0100-4727, Rev RA

December 2007

Rosemount 8700 Series

Repeatability

±0.1% of reading

Response Time

0.2 seconds maximum response to step change in input

Stability

±0.1% of rate over six months

Ambient Temperature Effect

±1% per 100 °F (37.8 °C)

Mounting Position Effect

None when installed to ensure flowtube sensor remains full.

Physical Specifications

Mounting

Integrally mounted transmitters are factory-wired and do not require interconnecting cables. The transmitter can rotate in 90° increments. Remote mounted transmitters require only a single conduit connection to the flowtube sensor.

Non-Wetted Materials (Flowtube Sensor)

Flowtube Sensor

304 Stainless Steel (wrapper), 304 Stainless Steel (pipe)

Terminal Junction Box

Cast aluminum, polyurethane coated
Optional: 304 Stainless Steel

Paint

Polyurethane

Weight

TABLE 9. 8721 Flowtube Sensor weight

Line Size	Flowtube Sensor Only	008721-0350 Tri-Clamp fitting (each)
0.5	4.84 lbs (2.2 kg)	0.58
1.0	4.52 (2.1 kg)	0.68
1.5	5.52 (2.5 kg)	0.88
2.0	6.78 (3.1 kg)	1.30
2.5	8.79 (2.1 kg)	1.66
3.0	13.26 (2.1 kg)	2.22
4.0	21.04 (2.1 kg)	3.28

Aluminum remote junction box

Approximately 1 pound (0.45 kg)

SST remote junction box

Approximately 2.5 pounds (1.13 kg)

Process Wetted Materials (Flowtube Sensor)

Liner

PFA with Ra < 32μinch (0.81μm)

Electrodes

316L SST with Ra < 15μ in. (0.38μ m)

Nickel Alloy 276 (UNS N10276) with Ra < 15μ in. (0.38μ m)

80% Platinum-20% Iridium with Ra < 15μ in. (0.38μm)

Process Connections

The Rosemount 8721 Sanitary Flowtube Sensor is designed using a standard IDF fitting as the basis for providing a flexible, hygienic interface for a variety of process connections. The Rosemount 8721 Flowtube Sensor has the threaded or “male” end of the IDF fitting on the ends of the base flowtube sensor. The flowtube sensor can be directly connected with user supplied IDF fittings and gaskets. If other process connections are needed, the IDF fittings and gaskets can be provided and welded directly into the sanitary process tubing, or can be supplied with adapters to standard Tri-Clamp® process connections. All connections are PED compliant for group 2 fluids.

Tri-Clamp® Sanitary Coupling

IDF Sanitary Coupling (screw type)

IDF specification per BS4825 part 4

ANSI Weld Nipple

DIN 11850 Weld Nipple

DIN 11851 (Imperial and Metric)

DIN 11864-1 form A

DIN 11864-2 form A

SMS 1145

Cherry-Burrell I-Line

Process Connection Material

316L Stainless Steel with Ra < 32μinch (0.81μm)

Optional Electropolished Surface Finish with Ra < 15μ in. (0.38μ m)

Process Connection Gasket Material

Silicone

EPDM

Rosemount 8700 Series

Viton

Electrical Connections (Flowtube Sensor)

Two 1/2-14 NPT connections with number 8 screw terminals are provided in the terminal enclosure for electrical wiring.

Flowtube Sensor Dimensions

Refer to Figure 13

NOTES



Rosemount 8714D Reference Calibration Standard Specifications

Functional Specifications

Ambient Temperature Limits

Operating

-30 to 140 °F (-34 to 60 °C)

Storage

-40 to 140 °F (-40 to 60 °C)

Humidity Limits

0 to 95% relative humidity

Performance Specifications

Accuracy

±0.05% of rate at 30 ft/s at 25°C

±0.10% of rate at 10 ft/s and 3 ft/s

Warm-up Time

30 minutes

Ambient Temperature Effect

< 0.015% of rate per 10 °F (< 0.027% per 10 °C)

Humidity Effect

No effect from 0 to 60% relative humidity < 0.10% of rate from 60 to 90% relative humidity

Long-Term Stability

< 0.10% of rate shift in one year

Physical Specifications

Electrical Connections

Electrical connections are compatible with 8712D, 8732 or 8742 terminal blocks. Not for use with the 8712H High Signal Transmitter.

Mounting

Any position is acceptable

Materials of Construction

Housing

Extruded aluminum

Covers

Stamped aluminum, silk-screened

Paint

Polyurethane

Weight

Approximately 3 lb (2 kg)

Product Certifications

Approved Manufacturing Locations

Rosemount Inc. — Eden Prairie, Minnesota, USA
Fisher-Rosemount Tecnologias de Flujo, S.A. de C.V. —
Chihuahua Mexico
Emerson Process Management Flow — Ede, The Netherlands

EUROPEAN DIRECTIVE INFORMATION

The EC declaration of conformity for all applicable European directives for this product can be found on our website at www.rosemount.com. A hard copy may be obtained by contacting our local sales office.

ATEX Directive

Rosemount Inc. complies with the ATEX Directive.

Type n protection type in accordance with EN50 021



- Closing of entries in the device must be carried out using the appropriate EExe or EExn metal cable gland and metal blanking plug or any appropriate ATEX approved cable gland and blanking plug with IP66 rating certified by an EU approved certification body.

For Rosemount 8732E transmitters:

Complies with Essential Health and Safety Requirements:

EN 60079-0: 2006
IEC 60079-1: 2007
EN 60079-7: 2007
EN 60079-11: 2007
EN 60079-26: 2004
EN 50281-1-1: 1998 + A1

European Pressure Equipment Directive (PED) (97/23/EC)

Rosemount 8705 and 8707 Magnetic Flowmeter flowtube sensors in line size and flange combinations:

Line Size: 1¹/₂ in. - 24 in. with all DIN flanges and ANSI 150 and ANSI 300 flanges. Also available with ANSI 600 flanges in limited line sizes.

Line Size: 30 in. - 36 in. with AWWA 125 flanges
QS Certificate of Assessment - EC No. PED-H-20
Module H Conformity Assessment

Rosemount 8711 Magnetic Flowmeter Flowtube Sensors

Line Sizes: 1.5, 2, 3, 4, 6, and 8 in.

QS Certificate of Assessment - EC No. PED-H-20
Module H Conformity Assessment

Rosemount 8721 Sanitary Magmeter Flowtube Sensors in line sizes of 1¹/₂ in. and larger:

Module A Conformity Assessment

All other Rosemount 8705/8707/8711/8721

Flowtube Sensors — in line sizes of 1 in. and less: Sound Engineering Practice

Flowtube Sensors that are SEP are outside the scope of PED and cannot be marked for compliance with PED.

Mandatory CE-marking for flowtube sensors in accordance with Article 15 of the PED can be found on the flowtube sensor body (CE 0575).

Flowtube Sensor category I is assessed for conformity per module A procedures.

Flowtube Sensor categories II – IV, use module H for conformity assessment procedures.

Electro Magnetic Compatibility (EMC) (2004/108/EC)

Models 8712D and 8742C - EN 50081-1: 1992, EN 50082-2: 1995,

Model 8732E - EN 61326: 1997: A1 + A2 + A3

Installed signal wiring should not be run together and should not be in the same cable tray as AC power wiring.

Device must be properly grounded or earthed according to local electric codes.

To improve protection against signal interference, shielded cable is recommended.

Low Voltage Directive (93/68/EEC)

Model 8712D and Model 8742C - EN 61010 -1: 1995

Low Voltage Directive (2006/95/EC)

Model 8732E - EN 61010 -1: 2001

Other important guidelines

Only use new, original parts.

To prevent the process medium escaping, do not unscrew or remove process flange bolts, adapter bolts or bleed screws during operation.

Maintenance shall only be done by qualified personnel.

CE CE Marking

Compliance with all applicable European Union Directives.
(Note: CE Marking is not available on Rosemount 8712H).

IECEX Directive

Rosemount Inc. complies with the IECEX Directive.

For Rosemount 8732E transmitters:

Complies with Essential Health and Safety Requirements:

IEC 60079-0 : 2004
IEC 60079-1 : 2007-04
IEC 60079-11 : 2006
IEC 60079-26 : 2006
IEC 60079-7 : 2006-07
IEC 61241-0 : 2004
IEC 61241-1 : 2004

HAZARDOUS LOCATIONS PRODUCT APPROVALS OFFERING

The Rosemount 8700 Series Magnetic Flowmeters offer many different hazardous locations certifications. The table below provides an overview of the available hazardous area approval options. Equivalent hazardous locations certifications for flowtube sensor and transmitter must match in integrally mounted magnetic flowmeter systems. Remote mounted magnetic flowmeter systems do not require matched hazardous location certifications. For complete information about the hazardous area approval codes listed, see Hazardous Location Certifications starting on page 38.

TABLE 10. Factory Mutual (FM) Approvals Offering

Transmitter	8732E			8712D ⁽¹⁾			8742C			8712H ⁽¹⁾	
	Flowtube Sensor	8705	8707	8711	8705	8707	8711	8705	8707	8711	8707
FM Category		Hazardous Area Approval Code									
Non-Classified Locations											
Transmitter		NA	NA	NA	NA	NA	NA	NA	NA	NA	N0
Flowtube Sensor		NA	N0	NA	NA	N0	NA	NA	N0	NA	N0
Suitable for Class I, Division 1											
Explosion-Proof											
Trans: Groups C, D T6		E5 ⁽²⁾	-	E5	-	-	-	E5 ⁽²⁾	-	E5	-
Tube: Groups C, D T6		E5 ⁽²⁾	-	E5	-	-	-	E5 ⁽²⁾	-	E5	-
Explosion-Proof with Intrinsically Safe Output											
Trans: Groups C, D T6		E5 ⁽²⁾⁽³⁾	-	E5 ⁽³⁾	-	-	-	K5	-	K5	-
Tube: Groups C, D T6		E5 ⁽²⁾	-	E5	-	-	-	E5 ⁽²⁾	-	E5	-
Suitable for Class I, Division 2											
Non-Flammable Fluids											
Trans: Groups A,B,C,D T4		N0	N0	N0	N0	N0	N0	N0	N0	N0	N0
Tube: Groups A,B,C,D T5		N0	N0 ⁽⁴⁾	N0	N0	N0 ⁽⁴⁾	N0	N0	N0 ⁽⁴⁾	N0	N0 ⁽⁴⁾
Flammable Fluids											
Trans: Groups A,B,C,D T4		N5	N5	N5	N5	N5	N5	N5	N5	N5	N5
Tube: Groups A,B,C,D T5		N5	N5 ⁽⁴⁾	N5	N5	N5 ⁽⁴⁾	N5	N5	N5 ⁽⁴⁾	N5	N5 ⁽⁴⁾
Non-Flammable Fluids with Intrinsically Safe Output											
Trans: Groups A,B,C,D T4		N0 ⁽³⁾	N0 ⁽³⁾	N0 ⁽³⁾	-	-	-	K0	K0	K0	-
Tube: Groups A,B,C,D T5		N0	N0 ⁽⁴⁾	N0	-	-	-	N0	N0 ⁽⁴⁾	N0	-
Other Certifications		Product Certification Code⁽⁵⁾									
European Pressure Equipment Directive (PED)		PD	-	PD	PD	-	PD	PD	-	PD	-
CRN		CN	CN	CN	CN	CN	CN	CN	CN	CN	CN
NSF 61 Drinking Water ⁽⁶⁾		DW	-	DW	DW	-	DW	DW	-	DW	-

(1) Remote Transmitter Only

(2) Available in line sizes 0.5 in. to 8 in. (15 mm to 200 mm) only

(3) For I.S. Output, Output Code B must be ordered

(4) 8707 Flowtube Sensor has Temp Code - T3C

(5) Product Certification Codes are added to the Flowtube Sensor model number only

(6) Only available with PTFE (all line sizes) or Polyurethane (4 in. or larger) Lining Materials and 316L SST Electrodes

Rosemount 8700 Series

TABLE 11. Canadian Standards Association (CSA) Approvals Offering

	Transmitter	8732E			8712D ⁽¹⁾			8742C			8712H ⁽¹⁾
	Flowtube Sensor	8705	8707	8711	8705	8707	8711	8705	8707	8711	8707
FM Category		Hazardous Area Approval Code									
Non-Classified Locations											
Transmitter		NA	-	NA	NA	-	NA	NA	-	NA	-
Flowtube Sensor		NA	-	NA	NA	-	NA	NA	-	NA	-
Suitable for Class I, Division 2											
Non-Flammable Fluids											
Trans: Groups A,B,C,D T4		N0	N0	N0	N0	N0	N0	N0	N0	N0	N0
Tube: Groups A,B,C,D T5		N0	N0 ⁽²⁾	N0	N0	N0 ⁽²⁾	N0	N0	N0 ⁽²⁾	N0	N0 ⁽²⁾
Other Certifications		Product Certification Code⁽³⁾									
European Pressure Equipment Directive (PED)		PD	-	PD	PD	-	PD	PD	-	PD	-
CRN		CN	CN	CN	CN	CN	CN	CN	CN	CN	CN
NSF 61 Drinking Water ⁽⁴⁾		DW	-	DW	DW	-	DW	DW	-	DW	-

(1) Remote Transmitter Only

(2) 8707 Flowtube Sensor has Temp Code - T3C

(3) Product Certification Codes are added to the Flowtube Sensor model number only

(4) Only available with PTFE (all line sizes) or Polyurethane (4 in. or larger) Lining Materials and 316L SST Electrodes

TABLE 12. ATEX Approvals Offering

Transmitter	8732E			8712D ⁽¹⁾			8742C			8712H ⁽¹⁾	
	Flowtube Sensor	8705	8707	8711	8705	8707	8711	8705	8707	8711	8707
ATEX Category		Hazardous Area Approval Code									
Non-Hazardous											
Trans: LVD and EMC		NA	-	NA	NA	-	NA	NA	-	NA	-
Tube: LVD and EMC		NA	-	NA	NA	-	NA	NA	-	NA	-
Equipment Category 2											
Gas Group IIB											
Trans: Ex d IIB T6		ED	-	ED	-	-	-	ED	-	ED	-
Tube: Ex e ia IIC T3...T6		KD ⁽²⁾	-	KD ⁽²⁾	-	-	-	KD ⁽²⁾	-	KD ⁽²⁾	-
Gas Group IIC											
Trans: Ex d IIC T6		E1	-	E1	-	-	-	E1	-	E1	-
Tube: Ex e ia IIC T3...T6		E1	-	E1	-	-	-	E1	-	E1	-
Gas Group IIB with Intrinsically Safe Output											
Trans: Ex de [ia] IIB T6		ED ⁽³⁾	-	ED ⁽³⁾	-	-	-	KD ⁽²⁾	-	KD ⁽²⁾	-
Tube: Ex e ia IIC T3...T6		KD ⁽²⁾	-	KD ⁽²⁾	-	-	-	KD ⁽²⁾	-	KD ⁽²⁾	-
Gas Group IIC with Intrinsically Safe Output											
Trans: Ex de [ia] IIC T6		E1 ⁽³⁾	-	E1 ⁽³⁾	-	-	-	K1	-	K1	-
Tube: Ex e ia IIC T3...T6		E1	-	E1	-	-	-	E1	-	E1	-
Equipment Category 3											
Gas Group IIC											
Trans: Ex nA nL IIC T4		N1	-	N1	N1	-	N1	-	-	-	-
Tube: Ex nA [L] IIC T3...T6		N1	-	N1	N1	-	N1	-	-	-	-
Equipment Category 1 - Dust Environment											
Dust Environment Only											
Trans: Dust Ignition Proof		ND	-	ND	-	-	-	-	-	-	-
Tube: Dust Ignition Proof		ND	-	ND	-	-	-	-	-	-	-
Other Certifications											
Product Certification Code⁽⁴⁾											
European Pressure Equipment Directive (PED)		PD	-	PD	PD	-	PD	PD	-	PD	-
CRN		CN	CN	CN	CN	CN	CN	CN	CN	CN	CN
NSF 61 Drinking Water ⁽⁵⁾		DW	-	DW	DW	-	DW	DW	-	DW	-

(1) Remote Transmitter Only

(2) With integral mount transmitter, approval is valid for Gas Group IIB

(3) For I.S. Output, Output Code B must be ordered

(4) Product Certification Codes are added to the Flowtube Sensor model number only

(5) Only available with PTFE (all line sizes) or Polyurethane (4 in. or larger) Lining Materials and 316L SST Electrodes

Rosemount 8700 Series

TABLE 13. IECEx Approvals Offering

	Transmitter		8732E ⁽¹⁾		
	Flowtube Sensor	8705	8707	8711	
IECEx Category		Hazardous Area Approval Code			
Non-Hazardous					
Trans: LVD and EMC		NA	-	NA	
Tube: LVD and EMC		NA	-	NA	
Equipment Category 2					
Gas Group IIB					
Trans: Ex d IIB T6		EF	-	EF	
Gas Group IIC					
Trans: Ex d IIC T6		E7	-	E7	
Gas Group IIB with Intrinsically Safe Output					
Trans: Ex de [ia] IIB T6		EF ⁽²⁾	-	EF ⁽³⁾	
Gas Group IIC with Intrinsically Safe Output					
Trans: Ex de [ia] IIC T6		E1 ⁽³⁾	-	E1 ⁽³⁾	
Equipment Category 3					
Gas Group IIC					
Trans: Ex nA nL IIC T4		N7	-	N7	
Equipment Category 1 - Dust Environment					
Dust Environment Only					
Trans: Dust Ignition Proof		NF	-	NF	
Other Certifications		Product Certification Code⁽³⁾			
European Pressure Equipment Directive (PED)		PD	-	PD	
CRN		CN	CN	CN	
NSF 61 Drinking Water ⁽⁴⁾		DW	-	DW	

(1) Available in remote mount configuration only. Requires equivalent ATEX approval on the flowtube sensor

(2) For I.S. Output, Output Code B must be ordered

(3) Product Certification Codes are added to the Flowtube Sensor model number only

(4) Only available with PTFE (all line sizes) or Polyurethane (4 in. or larger) Lining Materials and 316L SST Electrodes

HAZARDOUS LOCATION CERTIFICATIONS

Equivalent Hazardous Location Certifications for flowtube sensor and transmitter must match in integrally-mounted magnetic flowmeter systems. Remote-mounted systems do not require matched hazardous location certification option codes.

Transmitter Approval Information

TABLE 14. Transmitter Option Codes

Approval Codes	Rosemount 8732E	Rosemount 8712D	Rosemount 8712H	Rosemount 8742 Transmitter	
				fieldbus Output	IS fieldbus Output
NA	•	•		•	
N0	•	•	•	•	
N1	•	•			
N5	•	•	•	•	
N7	•				
ND	•				
NF	•				
E1	•			•	
E5	•			•	
E7	•				
ED	•			•	
K0					•
K1					•
K5					•
KD ⁽¹⁾					•

(1) Refer to Table 17 on page 44 for relation between ambient temperature, process temperature, and temperature class.

Product Data Sheet

00813-0100-4727, Rev RA

December 2007

Rosemount 8700 Series

North American Certifications Factory Mutual (FM)

NOTE

For intrinsically safe (IS) outputs on the 8732E output option code B must be selected.

IS outputs for Class I, Division 1, Groups A, B, C, D.

Temp Code – T4 at 60°C

NOTE

For the 8732E transmitters with a local operator interface (LOI), the lower ambient temperature limit is -20 °C.

N0 Division 2 Approval (All transmitters)

Reference Rosemount Control Drawing 08742-1051 (8742C) or 08732-1052 (8732E/8742C).

Class I, Division 2, Groups A, B, C, D

Temp Codes – T4 (8712 at 40°C, 8742 at 60°C),

T4 (8732 at 60°C: $-50\text{ °C} \leq T_a \leq 60\text{ °C}$)

Dust-ignition proof Class II/III, Division 1, Groups E, F, G

Temp Codes – T4 (8712 at 40°C), T5 (8732 at 60°C), T6

(8742 at 60°C)

Enclosure Type 4X

K0 Division 2 Approval with Intrinsically Safe Output (8742 Only)

Reference Rosemount Control Drawing 08742-1051

Class I, Division 2, Groups A, B, C, D with IS output for

Class I, Division 1, Groups A, B, C, D.

Temp Code – T4 at 60°C

Dust-ignition proof Class II/III, Division 1, Groups E, F, G

Temp Code – T6 at 60°C

Enclosure Type 4X

K5 Explosionproof Approval with Intrinsically Safe Output (8742 only)

Reference Rosemount Control Drawing 08742-1051

Explosion-Proof for Class I, Division 1, Groups C, D with IS

output for Class I, Division 1, Groups A, B, C, D.

Temp Code – T4 at 60°C

Dust-ignition proof Class II/III, Division 1, Groups E, F, G

Temp Code – T6 at 60°C

Class I, Division 2, Groups A, B, C, D

Temp Codes – T4 (8742 at 60°C)

Enclosure Type 4X

N5 Division 2 Approval (All Transmitters) For flowtube sensors with IS electrodes only

Reference Rosemount Control Drawing 08742-1051 (8742C) or 08732-1052 (8732E).

Class I, Division 2, Groups A, B, C, D

Temp Codes – T4 (8712 at 40°C, 8742 at 60°C),

T4 (8732 at 60°C: $-50\text{ °C} \leq T_a \leq 60\text{ °C}$)

Dust-ignition proof Class II/III, Division 1, Groups E, F, G

Temp Codes – T4 (8712 at 40°C), T5 (8732 at 60°C), T6

(8742 at 60°C)

Enclosure Type 4X

E5 Explosion-Proof Approval (8732 and 8742 only)

Reference Rosemount Control Drawing 08732-1052

Explosion-Proof for Class I, Division 1, Groups C, D

Temp Code – T6 at 60°C

Dust-ignition proof Class II/III, Division 1, Groups E, F, G

Temp Code – T5 at 60°C

Class I, Division 2, Groups A, B, C, D

Temp Codes – T4 (8742 at 60°C), T4 (8732 at 60°C)

Enclosure Type 4X

Canadian Standards Association (CSA)

NOTE

For intrinsically safe (IS) outputs on the 8732E output option code B must be selected.

IS outputs for Class I, Division 1, Groups A, B, C, D.

Temp Code – T4 at 60°C

N0 Division 2 Approval

Reference Rosemount Control Drawing 08732-1051 (8732E or 8742C only)

Class I, Division 2, Groups A, B, C, D

Temp Codes – T4 (8732 at 60°C: $-50\text{ °C} \leq T_a \leq 60\text{ °C}$),

T4 (8742 at 60°C)

Dust-ignition proof Class II/III, Division 1, Groups E, F, G

Temp Codes – T4 (8712 at 40°C), T5 (8732 at 60°C), T6

(8742 at 60°C)

Enclosure Type 4X

K0 Division 2 Approval with Intrinsically Safe Output (8742 Only)

Reference Rosemount Control Drawing 08742-1052

Class I, Division 2, Groups A, B, C, D with IS output for

Class I, Division 1, Groups A, B, C, D. Temp Code – T4 at

60°C

Dust-ignition proof Class II/III, Division 1, Groups E, F, G

Temp Code – T6 at 60°C

Enclosure Type 4X

European Certifications

NOTE

For intrinsically safe (IS) outputs on the 8732E output option code B must be selected.

IS outputs for Ex de [ia] IIB or IIC T6

E1 ATEX Flameproof

Hydrogen gas group

8732 - Certificate No.: KEMA 07ATEX0073 X  II 2G

Ex de IIC or Ex de [ia] IIC T6 (-20°C ≤ Ta ≤ +57°C)
with LOI T6 (-20°C ≤ Ta ≤ +57°C)

8742 - Certificate No.: 03ATEX2159X  II 2G

EEx de IIB + H₂ T6 (-20°C ≤ Ta ≤ +65°C)

V_{max} = 250 V AC or 42 V DC

 0575

ED ATEX Flameproof

8732 - Certificate No.: KEMA 07ATEX0073 X  II 2G

Ex de IIB or Ex de [ia] IIB T6 (-20°C ≤ Ta ≤ +57°C)
with LOI T6 (-20°C ≤ Ta ≤ +57°C)

V_{max} = 250 V AC or 42 V DC

 0575

ND ATEX Dust

8732 - Certificate No.: KEMA 06ATEX0006  II 1D

max ΔT = 40 °K⁽¹⁾

Amb. Temp. Limits: (-20 °C ≤ Ta ≤ + 65 °C)

V_{max} = 250 V AC or 42 V DC

IP 66

 0575

SPECIAL CONDITIONS FOR SAFE USE

(KEMA 07ATEX0073 X):

If the Rosemount 8732 Flow Transmitter is used integrally with the Rosemount 8705 or 8711 Flowtube Sensors, it shall be assured that the mechanical contact areas of the Flowtube Sensor and Flow Transmitter comply with the requirements for flat joints according to standard EN/IEC 60079-1 clause 5.2.

The relation between ambient temperature, process temperature, and temperature class is to be taken from the table under (15 - description) above. **(See Table 17)**

The electrical data is to be taken from the summary under (15 - electrical data) above. **(See Table 16)**

If the Rosemount 8732 Flow Transmitter is used integrally with the Junction Box, it shall be assured that the mechanical contact areas of the Junction Box and Flow Transmitter comply with the requirements for flanged joints according to standard EN/IEC 60079-1 clause 5.2.

Per EN60079-1: 2004 the gap of the joint between transmitter and remote junction box/flowtube sensor is less than required per table 1 clause 5.2.2, and is only approved for use with an approved Rosemount transmitter and approved junction box/flowtube sensor.

INSTALLATION INSTRUCTIONS:

The cable and conduit entry devices and blanking elements shall be of a certified flameproof type, suitable for the conditions of use and correctly installed. With the use of conduit, a certified stopping box shall be provided immediately to the entrance of the enclosure.

ED 8742 - Certificate No.: KEMA03ATEX2159X II 2G

EEx de IIB T6 (Ta = -20°C to +65°C)

V_{max} = 250 V AC or 50 V DC

 0575

K1 ATEX Flameproof with

Intrinsically Safe Output (8742 only)

Certificate No.: KEMA03ATEX2159x  II 2G

ATEX EEx de [ia] IIC T6 (-20 °C ≤ Ta ≤ +65 °C)

V_{max} = 250 V AC or 50 V DC

 0575

See Table 12 for Electrical Parameters

KD ATEX Flameproof with

Intrinsically Safe Output (8742 only)

Certificate No.: KEMA03ATEX2159X  II 2G

EEx de [ia] IIB T6 (Ta = -20°C to +65°C)

V_{max} = 250 V AC or 50 V DC

 0575

See Table 16 for Electrical Parameters

SPECIAL CONDITIONS FOR SAFE USE (X) (03ATEX2159X):

The relation between ambient temperature, process temperature and temperature class is to be taken from the table under (15 - description) above. **(See Table 17)**.

If the Rosemount 8742C Flow Transmitter is used integrally with the Junction Box, it shall be assured that the mechanical contact areas of the Junction Box and Flow Transmitter comply with the requirements for flanged joints according to standard EN 50018, clause 5.2.

INSTALLATION INSTRUCTIONS:

The cable and conduit entry devices and the closing elements shall be of a certified increased safety type, suitable for the conditions of use and correctly installed.

At ambient temperatures above 50°C, the flow meter shall be used with heat resistant cables with a temperature rating of at least 90°C.

A Junction Box in type of explosion protection increased safety "e" may be attached to the base of the Rosemount 8732E or 8742C Flow Transmitter, permitting remote mounting of the Rosemount 8705 and 8711 Flowtube Sensors.

Ambient temperature range of the Junction Box: -20 °C to +65 °C.

The Junction Box is classified as II 2 G Ex e IIB T6 and certified under KEMA 07ATEX0073 X and KEMA 03ATEX2052X.

(1) Max surface temperature is 40 °C above the ambient temperature conditions. Tmax = 100 °C

Product Data Sheet

00813-0100-4727, Rev RA

December 2007

Rosemount 8700 Series

N1 ATEX Type n

8712D - ATEX Certificate No: BASEEFA 05ATEX0170X

EEx nA nL IIC T4 (Ta = -50 °C to + 60 °C)

V_{max} = 42 V DC

CE 0575

8732 - ATEX Certificate No: BASEEFA 07ATEX0203X

Ex nA nL IIC T4 (Ta = -50 °C to + 60 °C)

V_{max} = 42 V DC

CE 0575

Remote Junction Box

8742 - Certificate No.: KEMA 03ATEX2052x II 2G

ATEX EEx e⁽¹⁾ T6 (Ta = -20 °C to +65 °C)

When installed per drawing 08732-1050

After de-energizing, wait 10 minutes before opening cover

CE 0575

⁽¹⁾ IIB + H₂ for E1, K1
IIB for ED, KD

8732 - Certificate No.: KEMA 07ATEX0073 X II 2G

ATEX Ex e⁽¹⁾ T6 (Ta = -20 °C to +57 °C)

When installed per drawing 08732-1060

After de-energizing, wait 10 minutes before opening cover

CE 0575

⁽¹⁾ IIC for E1
IIB for ED

International Certifications

NOTE

For intrinsically safe (IS) outputs on the 8732E output option code B must be selected.

IS outputs for Ex de [ia] IIB or IIC T6

E7 IECEx Flameproof

8732 - Certificate No.: KEM 07.0038X

Ex de IIC or Ex de [ia] IIC T6 (-20 °C ≤ Ta ≤ +57 °C)

V_{max} = 250 V AC or 42 V DC

EF IECEx Flameproof

8732 - Certificate No.: KEM 07.0038X

Ex de IIB or Ex de [ia] IIB T6 (-20 °C ≤ Ta ≤ +57 °C)

V_{max} = 250 V AC or 42 V DC

NF IECEx Dust

8732 - Certificate No.: KEM 07.0038X

Ex tD A20 IP66 T 100 °C

T6 (-20 °C ≤ Ta ≤ +57 °C)

V_{max} = 250 V AC or 42 V DC

SPECIAL CONDITIONS FOR SAFE USE (KEM 07.0038X):

If the Rosemount 8732 Flow Transmitter is used integrally with the Rosemount 8705 or 8711 Flowtube Sensors, it shall be assured that the mechanical contact areas of the Flowtube Sensor and Flow Transmitter comply with the requirements for flat joints according to standard EN/IEC 60079-1 clause 5.2.

The relation between ambient temperature, process temperature, and temperature class is to be taken from the table under (15 - description) above. (See Table 17)

The electrical data is to be taken from the summary under (15 - electrical data) above. (See Table 16)

If the Rosemount 8732 Flow Transmitter is used integrally with the Junction Box, it shall be assured that the mechanical contact areas of the Junction Box and Flow Transmitter comply with the requirements for flanged joints according to standard EN/IEC 60079-1 clause 5.2.

INSTALLATION INSTRUCTIONS:

The cable and conduit entry devices and blanking elements shall be of a certified flameproof type, suitable for the conditions of use and correctly installed. With the use of conduit, a certified stopping box shall be provided immediately to the entrance of the enclosure.

N7 IECEx Type n

8712D - Certificate No: IECEX BAS 07.0036X

EEx nA nL IIC T4 (Ta = -50 °C to + 60 °C)

V_{max} = 42 V DC

8732 - Certificate No: IECEX BAS 07.0062X

Ex nA nL IIC T4 (Ta = -50 °C to + 60 °C)

V_{max} = 42 V DC

Remote Junction Box

8732 - Certificate No.: KEM 07.0038X

IECEX Ex e⁽¹⁾ T6 (Ta = -20 °C to + 57 °C)

When installed per drawing 08732-1070

After de-energizing, wait 10 minutes before opening cover

⁽¹⁾ IIC for E7
IIB for EF

Rosemount 8700 Series

Flowtube Sensor Approval Information

TABLE 15. Flowtube Sensor Option Codes⁽¹⁾

Approval Codes	Rosemount 8705 Flowtube Sensor		Rosemount 8707 Flowtube Sensor		Rosemount 8711 Flowtube Sensor		Rosemount 8721 Flowtube Sensors
	For Non-flammable Fluids	For Flammable Fluids	For Non-flammable Fluids	For Flammable Fluids	For Non-flammable Fluids	For Flammable Fluids	For Non-flammable Fluids
NA	•						•
N0	•		•		•		
ND	•	•	•	•	•	•	•
N1	•	•			•	•	
N5	•	•	•	•	•	•	
N7	•	•			•	•	
ND	•	•			•	•	
NF	•	•			•	•	
E1	•	•			•	•	
E5 ⁽²⁾	•	•			•	•	
CD ⁽³⁾					•	•	
KD ⁽³⁾	•	•					

(1) CE Marking is standard on Rosemount 8705, 8711, and 8721. No hazardous location certifications are available on the Rosemount 570TM.

(2) Available in line sizes up to 8 in. (200 mm) only.

(3) Refer to Table 17 on page 44 for relation between ambient temperature, process temperature, and temperature class.

North American Certifications

Factory Mutual (FM)

N0 Division 2 Approval for Non-Flammable Fluids (All Flowtube Sensors)

Class I, Division 2, Groups A, B, C, D
 Temp Code – T5 (8705/8711 at 60°C)
 Temp Code – T3C (8707 at 60°C)
 Dust-Ignition proof Class II/III, Division 1, Groups E, F, G
 Temp Code – T6 (8705/8711 at 60°C)
 Temp Code – T3C (8707 at 60°C)
 Enclosure Type 4X

N0 for 8721 Hygienic Flowtube Sensor

Factory Mutual (FM) Ordinary Location;
 CE Marking; 3-A Symbol Authorization #1222;
 EHEDG Type EL

N5 Division 2 Approval for Flammable Fluids (All Flowtube Sensors)

Class I, Division 2, Groups A, B, C, D
 Temp Code – T5 (8705/8711 at 60°C)
 Temp Code – T3C (8707 at 60°C)
 Dust-Ignition proof Class II/III, Division 1, Groups E, F, G
 Temp Code – T6 (8705/8711 at 60°C)
 Temp Code – T3C (8707 at 60°C)
 Enclosure Type 4X

E5 Explosion-Proof (8705 and 8711 Only)

Explosion-Proof for Class I, Division 1, Groups C, D
 Temp Code – T6 at 60°C
 Dust-Ignition proof Class II/III, Division 1, Groups E, F, G
 Temp Code – T6 at 60°C
 Class I, Division 2, Groups A, B, C, D
 Temp Code – T5 at 60°C
 Enclosure Type 4X

Canadian Standards Association (CSA)

N0 Suitable for Class I, Division 2, Groups A, B, C, D
 Temp Code – T5 (8705/8711 at 60°C)
 Temp Code – T3C (8707 at 60°C)

Dust-Ignition proof Class II/III, Division 1, Groups E, F, G
 Enclosure Type 4X

N0 for 8721 Hygienic Flowtube Sensor

Canadian Standards Association (CSA) Ordinary Location;
 CE Marking; 3-A Symbol Authorization #1222;
 EHEDG Type EL

Product Data Sheet

00813-0100-4727, Rev RA

December 2007

Rosemount 8700 Series

European Certifications

ND ATEX Dust

8732 - Certificate No.: KEMA 06ATEX0006  II 1D max
T = 40 °K(1) Amb. Temp. Limits: (-20 °C = Ta = +65 °C)
V_{max} = 40 V DC (pulsed)
IP 66
CE 0575

N1 ATEX Non-Sparking/Non-incendive (8705/8711 Only)

Certificate No: KEMA02ATEX1302X  II 3G
EEx nA [L] IIC T3... T6
Ambient Temperature Limits -20 to 65°C

SPECIAL CONDITIONS FOR SAFE USE (X):

The relation between ambient temperature, process temperature and temperature class is to be taken from the table under (15-description) above. - (See Table 13) The electrical data is to be taken from the summary under (15-electrical data above). (See Table 12)

E1, ATEX Increased Safety (Zone 1)

CD with IS Electrodes (8711 only)

Certificate No: KEMA03ATEX2052X  II 1/2G
EEx e ia IIC T3... T6 (Ta = -20 to +60°) (See Table 17)
CE 0575
V_{max} = 40 V DC (pulsed)

SPECIAL CONDITIONS FOR SAFE USE (X):

If the Rosemount 8732 Flow Transmitter is used integrally with the Rosemount 8705 or Rosemount 8711 Flowtube Sensors, it shall be assured that the mechanical contact areas of the Flowtube Sensor and Flow Transmitter comply with the requirements for flat joints according to standard EN 50018, clause 5.2. The relation between ambient temperature, process temperature and temperature class is to be taken from the table under (15-description) above. - (See Table 11) The electrical data is to be taken from the summary under (15-electrical data above). (See Table 12)

INSTALLATION INSTRUCTIONS:

At ambient temperature above 50°C, the flowmeter shall be used with heat resistant cables with a temperature rating of at least 90°C.

A fuse with a rating of maximum 0,7 A according to IEC 60127-1 shall be included in the coil excitation circuit if the flowtube sensors are used with other flow transmitters (e.g. Rosemount 8712).

E1, ATEX Increased Safety (Zone 1)

KD with IS Electrodes (8705 only)

Certificate No. KEMA 03ATEX2052X  II 1/2G
EEx e ia IIC T3... T6 (Ta = -20 to 60°C) (See Table 17)
CE 0575
V_{max} = 40 V DC (pulsed)

SPECIAL CONDITIONS FOR SAFE USE (X):

If the Rosemount 8732 Flow Transmitter is used integrally with the Rosemount 8705 or Rosemount 8711 Flowtube Sensors, it shall be assured that the mechanical contact areas of the Flowtube Sensor and Flow Transmitter comply with the requirements for flat joints according to standard EN 50018, clause 5.2. The relation between ambient temperature, process temperature and temperature class is to be taken from the table under (15-description) above. - (See Table 11) The electrical data is to be taken from the summary under (15-electrical data above). (See Table 12)

INSTALLATION INSTRUCTIONS:

At ambient temperature above 50°C, the flowmeter shall be used with heat resistant cables with a temperature rating of at least 90°C.

A fuse with a rating of maximum 0,7 A according to IEC 60127-1 shall be included in the coil excitation circuit if the flowtube sensors are used with other flow transmitters (e.g. Rosemount 8712).

Rosemount 8700 Series

TABLE 16. Electrical Data

Rosemount 8732 Flow Transmitter	
Power supply:	250 V AC, 1 A or 50 Vdc, 2,5 A, 20 W maximum
Pulsed output circuit:	30 V DC (pulsed), 0,25 A, 7,5 W maximum
4-20 mA output circuit:	30 V DC, 30 mA, 900 mW maximum
Rosemount 8705 and 8711 Flowtube Sensors	
Coil excitation circuit:	40 V DC (pulsed), 0,5 A, 20 W maximum
Electrode circuit:	in type of explosion protection intrinsic safety EEx ia IIC, $U_i = 5$ V, $I_i = 0.2$ mA, $P_i = 1$ mW, $U_m = 250$ V
Rosemount 8742C Flow Transmitter (EEx de version):	
Power supply:	250 V AC, 1 A, 40 VA or 50 Vdc, 2,5 A, 15 W maximum
Foundation fieldbus output:	30 V DC, 30 mA, 1 W maximum
Rosemount 8742C Flow Transmitter (EEx de [ia] version):	
Power supply:	250 V AC, 1 A, 40 VA or 50 V DC, 2,5 A, 15 W maximum
Foundation fieldbus output: (terminals + and -)	in type of explosion protection intrinsic safety EEx, only for connection to a certified intrinsically safe circuit, with the following maximum values:
	$U_i = 30$ V
	$I_i = 380$ mA
	$P_i = 5,32$ W
	$C_i = 4,4$ nF
	$L_i = 0$ mH

TABLE 17. Relation between ambient temperature, process temperature, and temperature class⁽¹⁾

Meter Size (Inches)	Maximum Ambient Temperature	Maximum Process Temperature	Temperature Class
1/2	115°F (65°C)	239°F (115°C)	T3
1	149°F (65°C)	248°F (120°C)	T3
1	95°F (35°C)	95°F (35°C)	T4
1 1/2	149°F (65°C)	257°F (125°C)	T3
1 1/2	122°F (50°C)	148°F (60°C)	T4
2	149°F (65°C)	257°F (125°C)	T3
2	149°F (65°C)	167°F (75°C)	T4
2	104°F (40°C)	104°F (40°C)	T5
3 - 36	149°F (65°C)	266°F (130°C)	T3
3 - 36	149°F (65°C)	194°F (90°C)	T4
3 - 36	131°F (55°C)	131°F (55°C)	T5
3 - 36	104°F (40°C)	104°F (40°C)	T6
6	115°F (65°C)	275°F (135°C)	T3
6	115°F (65°C)	230°F (110°C)	T4
6	115°F (65°C)	167°F (75°C)	T5
6	140°F (60°C)	140°F (60°C)	T6
8-60	115°F (65°C)	284°F (140°C)	T3
8-60	115°F (65°C)	239°F (115°C)	T4
8-60	115°F (65°C)	176°F (80°C)	T5
8-60	115°F (65°C)	156°F (69°C)	T6

(1) This table is applicable for CD and KD option codes only.

TABLE 18. Relation between the maximum ambient temperature, the maximum process temperature, and the temperature class⁽¹⁾

Maximum Ambient Temperature	Maximum process temperature °F (°C) per temperature class			
	T3	T4	T5	T6
0.5 in. flowtube sensor size				
149°F (65°C)	297°F (147°C)	138°F (59°C)	54°F (12°C)	18°F (-8°C)
140°F (60°C)	309°F (154°C)	151°F (66°C)	66°F (19°C)	28°F (-2°C)
131°F (55°C)	322°F (161°C)	163°F (73°C)	79°F (26°C)	41°F (5°C)
122°F (50°C)	334°F (168°C)	176°F (80°C)	90°F (32°C)	54°F (12°C)
113°F (45°C)	347°F (175°C)	189°F (87°C)	102°F (39°C)	66°F (19°C)
104°F (40°C)	351°F (177°C)	199°F (93°C)	115°F (46°C)	79°F (26°C)
95°F (35°C)	351°F (177°C)	212°F (100°C)	127°F (53°C)	90°F (32°C)
86°F (30°C)	351°F (177°C)	225°F (107°C)	138°F (59°C)	102°F (39°C)
77°F (25°C)	351°F (177°C)	237°F (114°C)	151°F (66°C)	115°F (46°C)
68°F (20°C)	351°F (177°C)	248°F (120°C)	163°F (73°C)	127°F (53°C)
1.0 in. flowtube sensor size				
149°F (65°C)	318°F (159°C)	158°F (70°C)	72°F (22°C)	34°F (1°C)
140°F (60°C)	331°F (166°C)	171°F (77°C)	84°F (29°C)	46°F (8°C)
131°F (55°C)	343°F (173°C)	183°F (84°C)	97°F (36°C)	59°F (15°C)
122°F (50°C)	351°F (177°C)	196°F (91°C)	109°F (43°C)	72°F (22°C)
113°F (45°C)	351°F (177°C)	207°F (97°C)	122°F (50°C)	84°F (29°C)
104°F (40°C)	351°F (177°C)	219°F (104°C)	135°F (57°C)	97°F (36°C)
95°F (35°C)	351°F (177°C)	232°F (111°C)	145°F (63°C)	109°F (43°C)
86°F (30°C)	351°F (177°C)	244°F (118°C)	158°F (70°C)	122°F (50°C)
77°F (25°C)	351°F (177°C)	257°F (125°C)	171°F (77°C)	135°F (57°C)
68°F (20°C)	351°F (177°C)	270°F (132°C)	183°F (84°C)	145°F (63°C)
1.5 in. flowtube sensor size				
149°F (65°C)	297°F (147°C)	160°F (71°C)	88°F (31°C)	55°F (13°C)
140°F (60°C)	307°F (153°C)	171°F (77°C)	97°F (36°C)	66°F (19°C)
131°F (55°C)	318°F (159°C)	181°F (83°C)	108°F (42°C)	77°F (25°C)
122°F (50°C)	329°F (165°C)	192°F (89°C)	118°F (48°C)	88°F (31°C)
113°F (45°C)	340°F (171°C)	203°F (95°C)	129°F (54°C)	97°F (36°C)
104°F (40°C)	351°F (177°C)	214°F (101°C)	140°F (60°C)	108°F (42°C)
95°F (35°C)	351°F (177°C)	223°F (106°C)	151°F (66°C)	118°F (48°C)
86°F (30°C)	351°F (177°C)	234°F (112°C)	160°F (71°C)	129°F (54°C)
77°F (25°C)	351°F (177°C)	244°F (118°C)	171°F (77°C)	140°F (60°C)
68°F (20°C)	351°F (177°C)	255°F (124°C)	181°F (83°C)	151°F (66°C)

Continued on Next Page

Rosemount 8700 Series

TABLE 18. Relation between the maximum ambient temperature, the maximum process temperature, and the temperature class⁽¹⁾

Maximum Ambient Temperature	Maximum process temperature °F (°C) per temperature class			
	T3	T4	T5	T6
2.0 in. flowtube sensor size				
149°F (65°C)	289°F (143°C)	163°F (73°C)	95°F (35°C)	66°F (19°C)
140°F (60°C)	300°F (149°C)	172°F 78(°C)	104°F (40°C)	75°F (24°C)
131°F (55°C)	309°F (154°C)	183°F (84°C)	115°F (46°C)	84°F (29°C)
122°F (50°C)	318°F (159°C)	192°F (89°C)	124°F (51°C)	95°F (35°C)
113°F (45°C)	329°F (165°C)	201°F (94°C)	135°F (57°C)	104°F (40°C)
104°F (40°C)	338°F (170°C)	212°F (100°C)	144°F (62°C)	115°F (46°C)
95°F (35°C)	349°F (176°C)	221°F (105°C)	153°F (67°C)	124°F (51°C)
86°F (30°C)	351°F (177°C)	232°F (111°C)	163°F (73°C)	135°F (57°C)
77°F (25°C)	351°F (177°C)	241°F (116°C)	172°F (78°C)	144°F (62°C)
68°F (20°C)	351°F (177°C)	252°F (122°C)	183°F (84°C)	153°F (67°C)
3 to 60 in. flowtube sensor size				
149°F (65°C)	351°F (177°C)	210°F (99°C)	117°F (47°C)	75°F (24°C)
140°F (60°C)	351°F (177°C)	223°F (106°C)	129°F (54°C)	90°F (32°C)
131°F (55°C)	351°F (177°C)	237°F (114°C)	144°F (62°C)	102°F (39°C)
122°F (50°C)	351°F (177°C)	250°F (121°C)	156°F (69°C)	117°F (47°C)
113°F (45°C)	351°F (177°C)	264°F (129°C)	171°F (77°C)	129°F (54°C)
104°F (40°C)	351°F (177°C)	266°F (130°C)	183°F (84°C)	144°F (62°C)
95°F (35°C)	351°F (177°C)	266°F (130°C)	198°F (92°C)	156°F (69°C)
86°F (30°C)	351°F (177°C)	266°F (130°C)	203°F (95°C)	171°F (77°C)
77°F (25°C)	351°F (177°C)	266°F (130°C)	203°F (95°C)	176°F (80°C)
68°F (20°C)	351°F (177°C)	266°F (130°C)	203°F (95°C)	176°F (80°C)

(1) This table is applicable for N1 option codes only.

Dimensional Drawings

FIGURE 6. Rosemount 8732E Transmitter

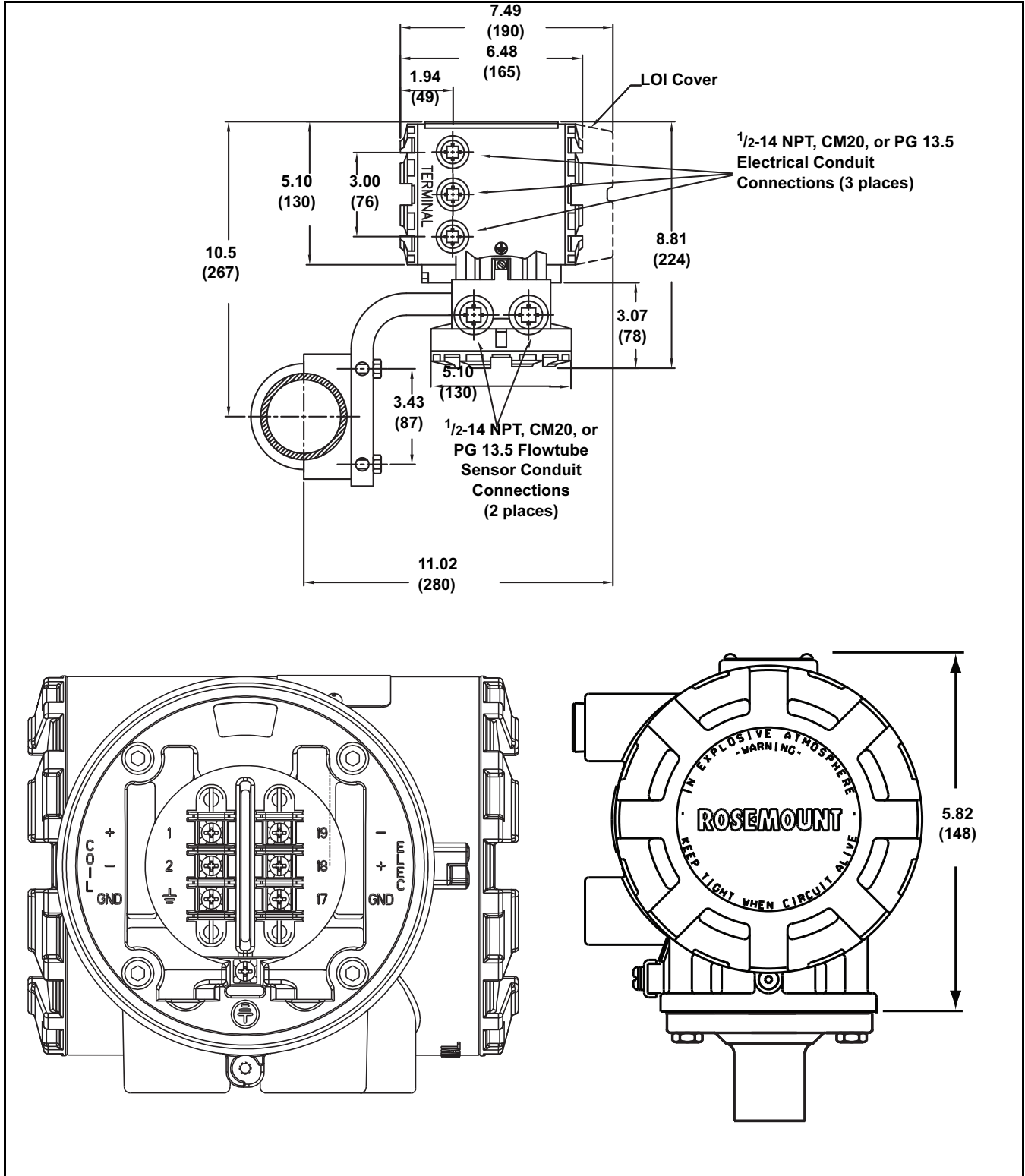

Rosemount 8700 Series

FIGURE 7. Rosemount 8712D/H Transmitter

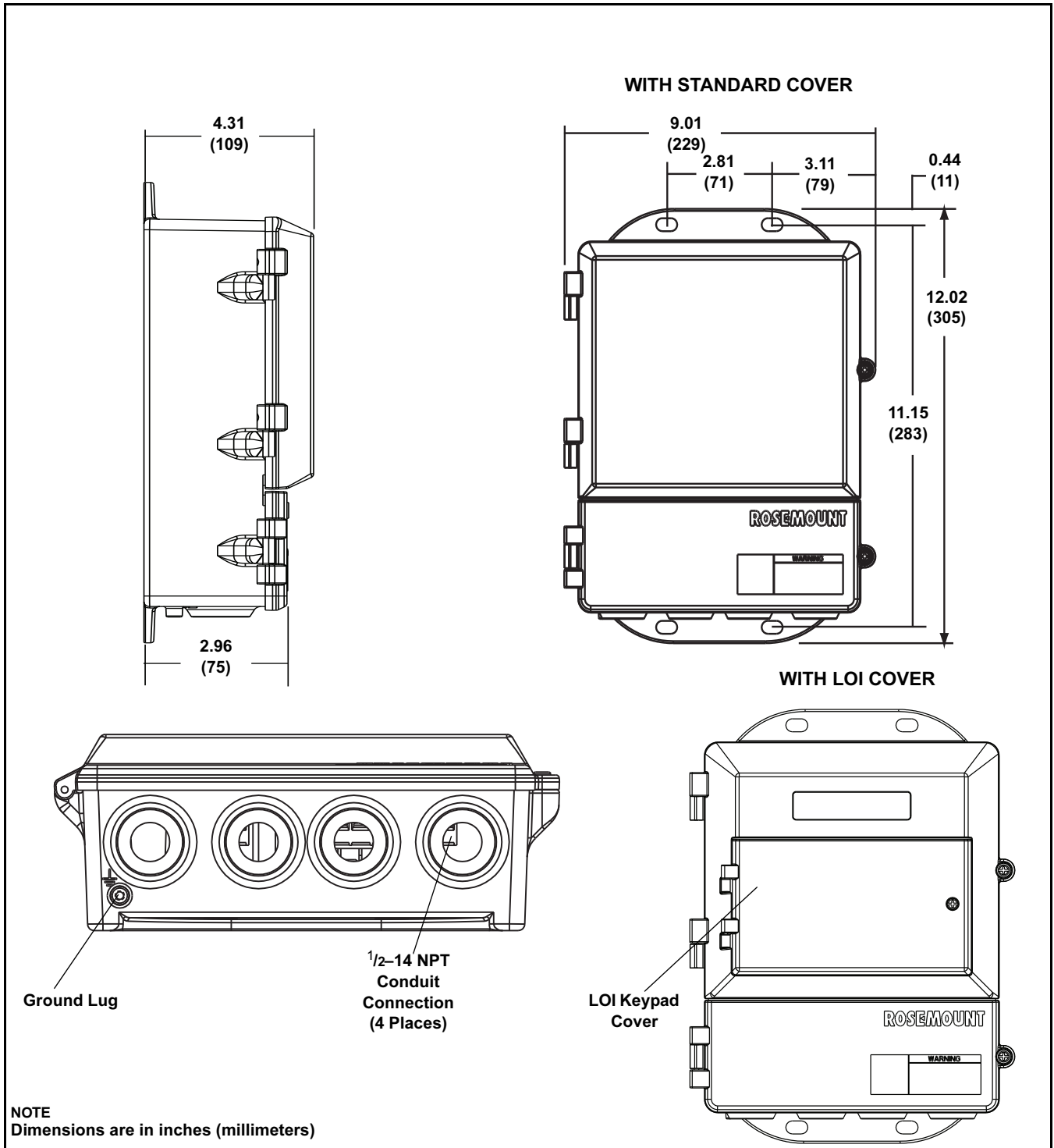
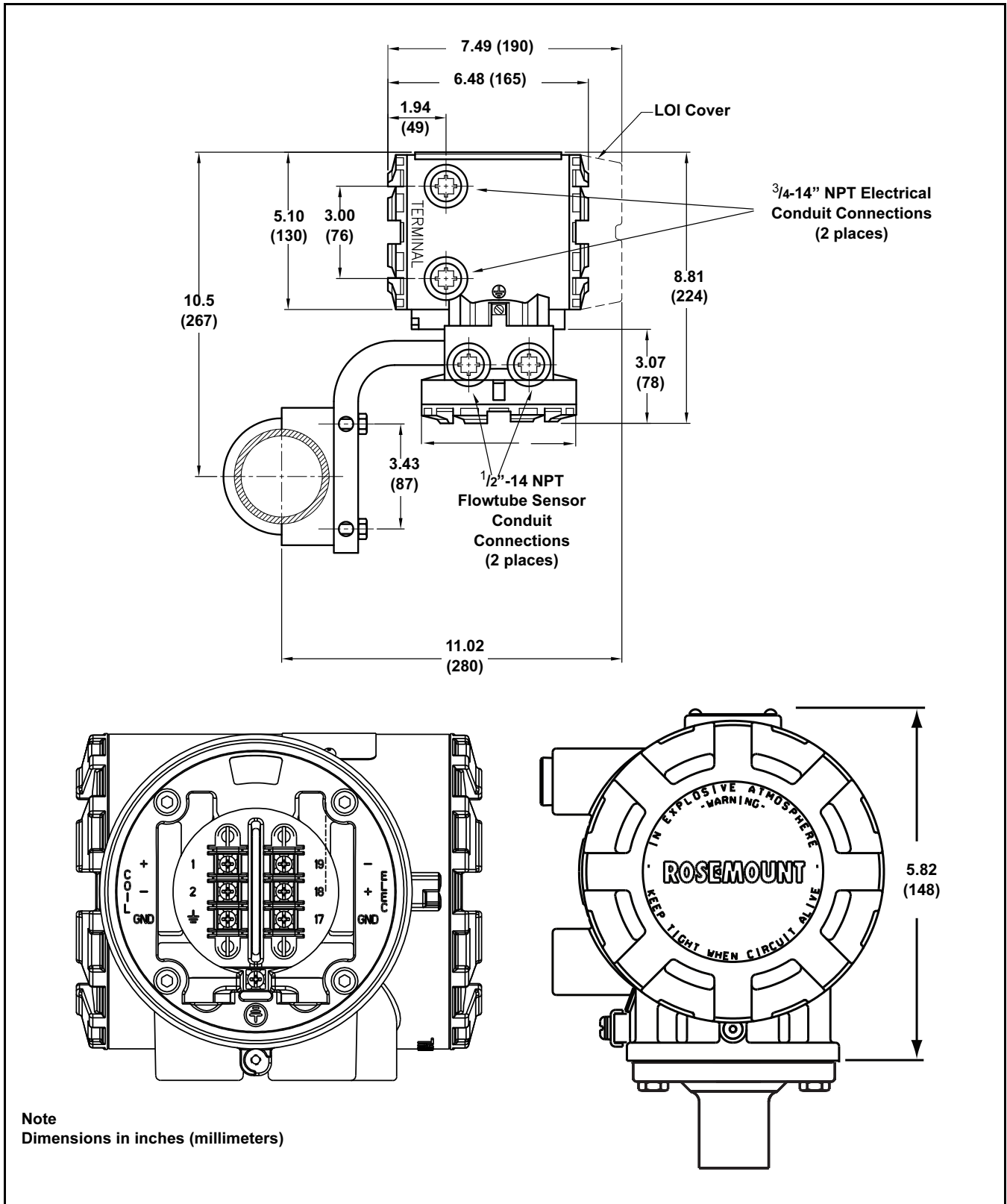
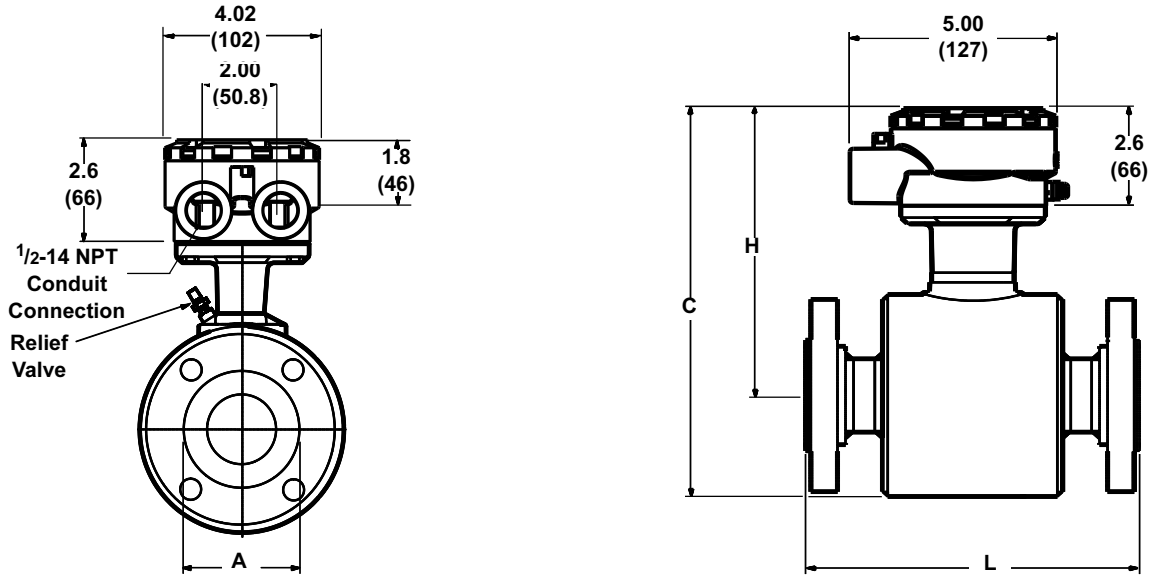

FIGURE 8. Rosemount 8742C Transmitter



Rosemount 8700 Series

FIGURE 9. Rosemount 8705 and 8707 Flowtube Sensors, Typical of 0.5- through 4-in. (15 through 100 mm) Line Sizes



Notes

Dimensions are in inches (millimeters)

See Table 19 and Table 20 for variable dimensions

W1 Housing Configuration (Sealed, welded housing with pressure relief valve)

FIGURE 10. Rosemount 8705 and 8707 Flowtube Sensors, Typical of 6- through 36-in. (150 through 900 mm) Line Sizes

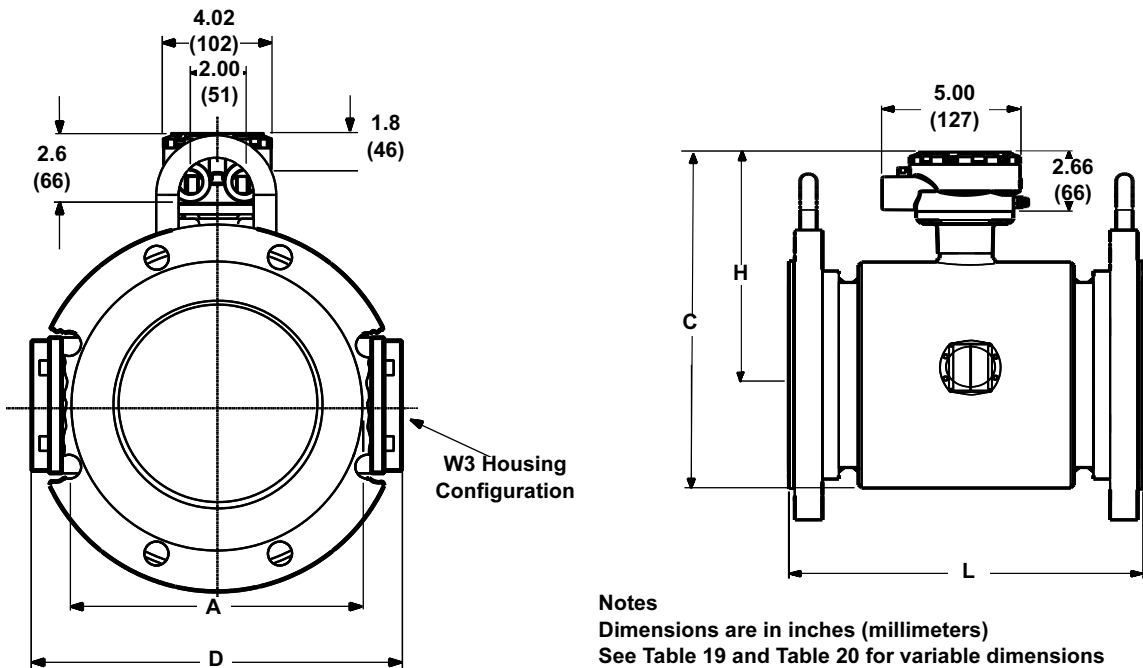

Notes

Dimensions are in inches (millimeters)

See Table 19 and Table 20 for variable dimensions

W3 Housing Configuration (Sealed welded housing with separate electrode compartments)

Product Data Sheet

00813-0100-4727, Rev RA

December 2007

Rosemount 8700 Series

TABLE 19. Rosemount 8705 and 8707 Dimensions in Inches (Millimeters) (Dimensions with ASME B16.5 (ANSI) Flanges) ⁽¹⁾
Refer to Dimensional Drawings, Figure 9, Figure 10, and Figure 12

Line Size ⁽²⁾ and Flange Rating	Body Height "H"	Liner Face Diameter "A"	Overall Flowtube Sensor Length "L" ⁽³⁾	Flange Diameter "D"	Liner Thickness	Inside Diameter
0.5-150	6.75 (171)	1.38 (35)	7.88 (200)	3.50 (89)	0.09 (2.3)	0.49 (12.5)
0.5-300	6.75 (171)	1.38 (35)	7.88 (200)	3.75 (95)	0.09 (2.3)	0.49 (12.5)
0.5-600	6.75 (171)	1.38 (35)	8.67 (220)	3.75 (95)	0.09 (2.3)	0.49 (12.5)
1-150	6.75 (171)	2.00 (51)	7.88 (200)	4.25 (108)	0.09 (2.3)	0.91 (23)
1-300	6.75 (171)	2.00 (51)	7.88 (200)	4.88 (124)	0.09 (2.3)	0.91 (23)
1-600	6.75 (171)	1.62 (41)	8.67 (220)	4.88 (124)	0.09 (2.3)	0.91 (23)
1-900	6.75 (171)	1.62 (41)	9.66 (245)	5.88 (149)	0.13 (3.3)	0.80 (20)
1.5-150	7.10 (180)	2.88 (73)	7.88 (200)	5.00 (127)	0.12 (3.1)	1.44 (37)
1.5-300	7.10 (180)	2.88 (73)	7.88 (200)	6.12 (155)	0.12 (3.1)	1.44 (37)
1.5-600	7.10 (180)	2.88 (73)	8.63 (219)	6.12 (155)	0.13 (3.3)	1.36 (35)
1.5-900	7.10 (180)	2.50 (64)	9.52 (242)	7.00 (178)	0.13 (3.3)	1.25 (32)
2-150	7.10 (180)	3.62 (92)	7.88 (200)	6.00 (152)	0.12 (3.1)	1.91 (49)
2-300	7.10 (180)	3.62 (92)	7.88 (200)	6.50 (165)	0.12 (3.1)	1.91 (49)
2-600	7.10 (180)	3.62 (92)	8.78 (223)	6.50 (165)	0.13 (3.3)	1.82 (46)
2-900	7.10 (180)	3.25 (83)	10.26 (261)	8.50 (216)	0.13 (3.3)	1.69 (43)
3-150	8.10 (206)	5.00 (127)	7.88 (200)	7.50 (191)	0.15 (3.8)	2.96 (75)
3-300	8.10 (206)	5.00 (127)	8.63 (219)	8.25 (210)	0.15 (3.8)	2.96 (75)
3-600	8.10 (206)	5.00 (127)	12.4 (315)	8.25 (210)	0.13 (3.3)	2.76 (70)
3-900	8.10 (206)	4.63 (118)	12.8 (326)	9.50 (241)	0.13 (3.3)	2.37 (60)
4-150	8.45 (215)	6.19 (157)	9.84 (250)	9.00 (229)	0.15 (3.8)	3.96 (101)
4-300	8.45 (215)	6.19 (157)	10.88 (276)	10.00 (254)	0.15 (3.8)	3.96 (101)
4-600	8.45 (215)	6.19 (157)	12.83 (326)	10.75 (273)	0.13 (3.3)	3.72 (95)
4-900	8.45 (215)	5.81 (148)	13.89 (353)	11.50 (292)	0.13 (3.3)	3.37 (86)
6-150	9.45 (240)	8.50 (216)	11.81 (300)	11.00 (279)	0.19 (4.8)	5.98 (152)
6-300	9.45 (240)	8.50 (216)	13.06 (332)	12.50 (318)	0.19 (4.8)	5.69 (144)
6-600	9.45 (240)	8.50 (216)	14.23 (361)	14.00 (356)	0.19 (4.8)	5.69 (144)
6-900	9.45 (240)	8.00 (203)	15.51 (394)	15.00 (381)	0.16 (4.1)	4.86 (123)
8-150	10.42 (265)	10.62 (270)	13.78 (350)	13.50 (343)	0.19 (4.8)	7.94 (202)
8-300	10.42 (265)	10.62 (270)	15.60 (396)	15.00 (381)	0.17 (4.3)	7.64 (194)
8-600	10.42 (265)	10.62 (270)	16.72 (428)	16.50 (419)	0.17 (4.3)	7.64 (194)
8-900	10.42 (265)	10.00 (254)	18.47 (469)	18.50 (470)	0.17 (4.3)	6.65 (169)
10-150	11.78 (299)	12.75 (324)	15.00 (381)	16.00 (406)	0.26 (6.5)	9.87 (251)
10-300	11.78 (299)	12.75 (324)	17.13 (435)	17.50 (444)	0.26 (6.5)	9.48 (241)
10-600	11.78 (299)	12.75 (324)	19.54 (496)	20.00 (508)	0.26 (6.5)	9.21 (234)
12-150	12.86 (327)	15.00 (381)	18.00 (457)	19.00 (483)	0.26 (6.7)	11.87 (301)
12-300	12.86 (327)	15.00 (381)	20.14 (512)	20.50 (52)	0.26 (6.7)	11.48 (292)
14-150	13.92 (354)	16.25 (413)	20.91 (531)	21.00 (533)	0.19 (4.8)	13.16 (334)
14-300	13.92 (354)	16.25 (413)	23.16 (588)	23.00 (584)	0.19 (4.8)	12.79 (325)
16-150	14.93 (379)	18.50 (470)	23.88 (607)	23.50 (597)	0.19 (4.8)	15.12 (384)
16-300	14.93 (379)	18.50 (470)	26.13 (664)	25.50 (648)	0.19 (4.8)	14.75 (375)
18-150	16.19 (411)	21.00 (533)	27.00 (686)	25.00 (635)	0.19 (4.8)	17.09 (434)
18-300	16.19 (411)	21.00 (533)	30.12 (765)	28.00 (711)	0.19 (4.8)	16.35 (415)
20-150	17.20 (437)	23.00 (584)	29.78 (756)	27.50 (698)	0.19 (4.8)	18.96 (482)
20-300	17.20 (437)	23.00 (584)	33.04 (839)	30.50 (774)	0.19 (4.8)	18.21 (463)
24-150	19.48 (495)	27.25 (692)	35.75 (908)	32.00 (813)	0.19 (4.8)	22.94 (583)
24-300	19.48 (495)	27.25 (692)	39.38 (1000)	36.00 (914)	0.19 (4.8)	22.06 (560)
30	22.23 (565)	33.80 (859)	37.00 (940)	38.75 (984)	0.19 (4.8)	28.75 (730)
36	26.10 (663)	40.27 (1023)	40.63 (1032)	46.00 (1168)	0.19 (4.8)	35.00 (889)

(1) AS2129 Table D and E flange dimensions match ANSI 150# dimensions.

(2) 30- and 36-in. AWWA C207 Table 2 Class D rated to 150 psi at 150 °F.

(3) When 2 grounding rings are specified, add 0.25 in. (6.35 mm) for 0.50- through 14-in. (15 through 350 mm) flowtube sensors, add 0.50 in. (12.7 mm) for 16-in. (400 mm) and larger. When lining protectors are specified, add 0.25 in. (6.35 mm) for ½- through 12-in. (15 through 300 mm) flowtube sensors, add 0.50 in. (12.7 mm) for 14- through 36-in. (350 through 900 mm) flowtube sensors.

Rosemount 8700 Series

TABLE 20. Rosemount 8705 Flowtube Sensor Dimensions with EN 1092-1 (DIN) Flanges in Millimeters (Inches)

Line Size ⁽¹⁾ and Flange Rating	Body Height "H"	Liner Face Diameter "A"	Overall Flowtube Sensor Length "L" ⁽²⁾	Flange Diameter "D"	Liner Thickness	Inside Diameter
15 mm PN 10-40	171 (6.75)	45 (1.77)	200 (7.88)	95 (3.74)	2.3 (0.09)	12.5 (.49)
25 mm PN 10-40	171 (6.75)	68 (2.68)	200 (7.88)	115 (4.53)	2.3 (0.09)	23.1 (.91)
40 mm PN 10-40	180 (7.10)	88 (3.46)	200 (7.87)	150 (5.91)	3.1 (0.12)	37 (1.44)
50 mm PN 10-40	180 (7.10)	102 (4.02)	200 (7.87)	165 (6.50)	3.1 (0.12)	49 (1.91)
80 mm PN 10-40	206 (8.10)	138 (5.43)	200 (7.87)	200 (7.87)	3.8 (0.15)	75.2 (2.96)
100 mm PN 10-16	215 (8.45)	162 (6.38)	250 (9.84)	220 (8.66)	3.8 (0.15)	100.6 (3.96)
100 mm PN 25-40	215 (8.45)	162 (6.38)	250 (9.84)	235 (9.25)	3.8 (0.15)	100.6 (3.96)
150 mm PN 10	240 (9.45)	212 (8.35)	300 (11.81)	285 (11.22)	4.7 (0.19)	152 (5.98)
150 mm PN 16	240 (9.45)	215 (8.46)	300 (11.81)	220 (8.66)	4.7 (0.19)	152 (5.98)
150 mm PN 25	240 (9.45)	218 (8.58)	300 (11.81)	300 (11.81)	4.7 (0.19)	152 (5.98)
150 mm PN 40	240 (9.45)	218 (8.58)	332 (13.07)	300 (11.81)	4.7 (0.19)	144 (5.67)
200 mm PN 10	265 (10.42)	268 (10.55)	350 (13.78)	240 (13.39)	4.9 (0.19)	202 (7.94)
200 mm PN 16	265 (10.42)	268 (10.55)	350 (13.78)	340 (13.39)	4.9 (0.19)	202 (7.94)
200 mm PN 25	265 (10.42)	278 (10.94)	350 (13.78)	360 (14.17)	4.9 (0.19)	202 (7.94)
200 mm PN 40	265 (10.42)	285 (11.22)	396 (15.60)	375 (14.76)	4.3 (0.17)	194 (7.64)
250 mm PN 10	299 (11.78)	320 (12.60)	381 (15.00)	395 (15.55)	6.6 (0.26)	251 (9.88)
250 mm PN 16	299 (11.78)	320 (12.60)	381 (15.00)	405 (15.94)	6.6 (0.26)	251 (9.88)
250 mm PN 25	299 (11.78)	335 (13.19)	381 (15.00)	425 (16.73)	6.6 (0.26)	251 (9.88)
250 mm PN 40	299 (11.78)	345 (13.58)	435 (17.13)	450 (17.72)	6.6 (0.26)	240 (9.45)
300 mm PN 10	327 (12.86)	370 (14.57)	457 (18.00)	445 (17.52)	6.6 (0.26)	302 (11.87)
300 mm PN 16	327 (12.86)	378 (14.88)	457 (18.00)	460 (18.11)	6.6 (0.26)	302 (11.87)
300 mm PN 25	327 (12.86)	395 (15.55)	457 (18.00)	485 (19.09)	6.6 (0.26)	302 (11.87)
300 mm PN 40	327 (12.86)	410 (16.14)	512 (20.14)	515 (20.28)	6.6 (0.26)	292 (11.48)
350 mm PN 10	354 (13.92)	430 (16.93)	531 (20.91)	505 (19.88)	4.8 (0.19)	334 (13.16)
350 mm PN 16	354 (13.92)	438 (17.24)	531 (20.91)	520 (20.47)	4.8 (0.19)	334 (13.16)
350 mm PN 25	354 (13.92)	450 (17.72)	531 (20.91)	555 (21.85)	4.8 (0.19)	334 (13.16)
350 mm PN 40	354 (13.92)	465 (18.31)	588 (23.16)	580 (22.83)	4.8 (0.19)	12.79 (325)
400 mm PN 10	379 (14.93)	482 (18.98)	607 (23.88)	565 (22.24)	4.8 (0.19)	384 (15.12)
400 mm PN 16	379 (14.93)	490 (19.29)	607 (23.88)	580 (22.83)	4.8 (0.19)	384 (15.12)
400 mm PN 25	379 (14.93)	505 (19.88)	607 (23.88)	620 (24.41)	4.8 (0.19)	384 (15.12)
400 mm PN 40	379 (14.93)	535 (21.06)	664 (26.13)	660 (25.98)	4.8 (0.19)	375 (14.75)
450 mm PN 10	411 (16.19)	532 (20.94)	682 (26.85)	615 (24.20)	4.8 (0.19)	438 (17.24)
450 mm PN 16	411 (16.19)	550 (21.65)	682 (26.85)	640 (25.20)	4.8 (0.19)	438 (17.24)
450 mm PN 25	411 (16.19)	555 (21.85)	682 (26.85)	670 (26.38)	4.8 (0.19)	438 (17.24)
450 mm PN 40	411 (16.19)	560 (22.05)	761 (29.97)	685 (26.97)	4.8 (0.19)	419 (16.49)
500 mm PN 10	437 (17.20)	585 (23.03)	756 (29.78)	670 (26.38)	4.8 (0.19)	482 (18.96)
500 mm PN 16	437 (17.20)	610 (24.02)	756 (29.78)	715 (28.15)	4.8 (0.19)	482 (18.96)
500 mm PN 25	437 (17.20)	615 (24.21)	756 (29.78)	730 (28.74)	4.8 (0.19)	482 (18.96)
500 mm PN 40	437 (17.20)	615 (24.21)	839 (33.04)	755 (29.72)	4.8 (0.19)	463 (18.21)
600 mm PN 10	495 (19.48)	685 (26.97)	908 (35.75)	780 (30.71)	4.8 (0.19)	583 (22.94)
600 mm PN 16	495 (19.48)	725 (28.54)	908 (35.75)	840 (33.07))	4.8 (0.19)	583 (22.94)
600 mm PN 25	495 (19.48)	720 (28.35)	908 (35.75)	845 (33.27)	4.8 (0.19)	581 (22.87)

Dimensions with EN 1092-1 (DIN) Flanges

(1) Consult factory for larger line sizes.

(2) When 2 grounding rings are specified, add 6.35 mm (0.25 in.) for 15 mm through 350 mm (½- through 14 in.) flowtube sensors or 12.7 mm (0.50 in.) for 400 mm (16 in.) and larger. When lining protectors are specified, add 6.35 mm (0.25 in.) for 15 mm through 300 mm (½- through 12-in.) flowtube sensors, 12.7 mm (0.50 in.) for 350 mm through 900 mm (14- through 36-in.) flowtube sensors.

FIGURE 11. Rosemount 8711 Dimensional Drawings (0.15-in. through 1-in. line sizes)

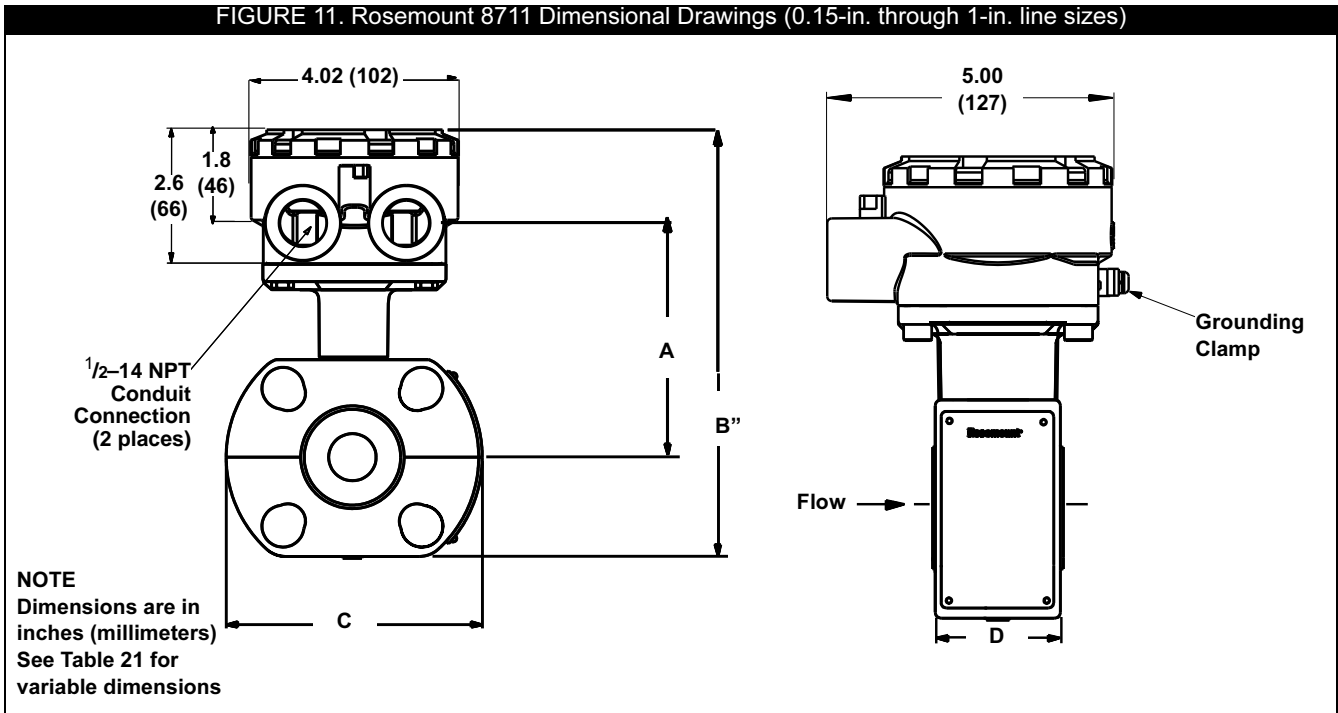
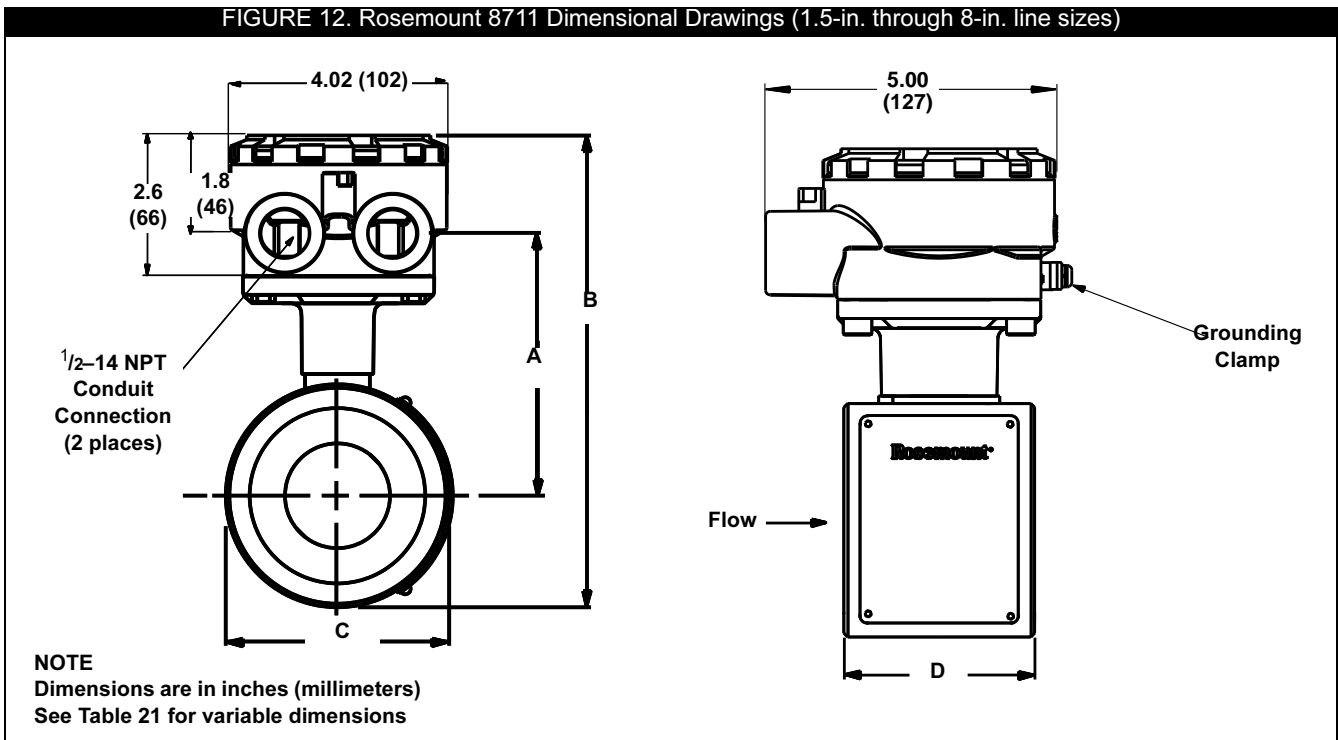

FIGURE 12. Rosemount 8711 Dimensional Drawings (1.5-in. through 8-in. line sizes)



Rosemount 8700 Series

TABLE 21. Rosemount 8711 Flowtube Sensor Dimensions and Weight

Nominal Line Size Inches (mm)	Flowtube Sensor Housing Dimensions							Flowtube Sensor Length				Weight lb (kg)	
	"A" Max.	"B"	"C"	"D"	Inside Diameter								
0.15 ⁽¹⁾	(4)	4.00 (102)	5.44 (138)	3.56 (90)	2.17 (55)	.150 (4)	4 (2)						
0.30 ⁽¹⁾	(8)	4.00 (102)	5.44 (138)	3.56 (90)	2.17 (55)	.300 (7)	4 (2)						
0.5	(15)	4.00 (102)	5.44 (138)	3.56 (90)	2.17 (55)	.593 (15)	4 (2)						
1	(25)	4.31 (109)	6.06 (154)	4.50 (114)	2.17 (55)	.970 (24)	5 (2)						
1.5	(40)	4.42 (112)	7.41 (188)	3.28 (83)	2.73 (69)	1.50 (38)	5 (2)						
2	(50)	4.64 (118)	7.94 (202)	3.91 (99)	3.26 (83)	1.92 (50)	7 (3)						
3	(80)	5.26 (134)	9.19 (233)	5.16 (131)	4.68 (119)	2.79 (76)	13 (6)						
4	(100)	5.87 (149)	10.41 (264)	6.38 (162)	5.88 (149)	3.70 (99)	22 (10)						
6	(150)	6.97 (177)	12.60 (320)	8.56 (217)	6.87 (174)	5.825 (148)	35 (16)						
8	(200)	8.00 (2003)	14.66 (372)	10.63 (270)	8.86 (225)	7.875 (200)	60 (27)						

(1) 0.15 and 0.30 in. (4 and 8 mm) flowtube sensors mount between 1/2-in. (13 mm) flanges.

FIGURE 13. Dimensional Drawings of Rosemount 8721 Flowtube Sensors Typical of 1 through 4inch (25 through 100mm) line sizes.

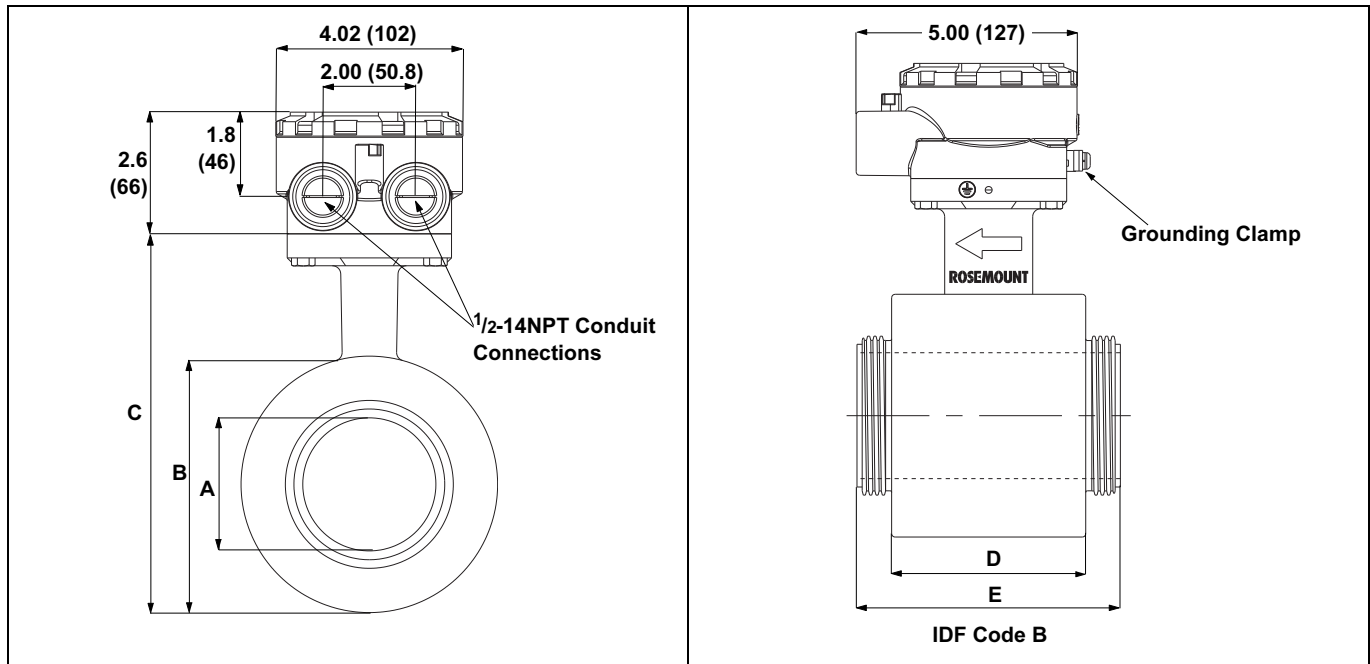

TABLE 22. Rosemount 8721 Dimensions in Inches (Millimeters). Refer to Dimensional Drawing Figure 13.

Line Size	Flowtube Sensor Dimensions A	Body Diameter B	Flowtube Sensor Height C	Body Length D	IDF Length E
1/2 (15)	0.62 (15.8)	2.87 (73.0)	5.51 (140.0)	2.13 (54.0)	3.66 (93.0)
1 (25)	0.87 (22.2)	2.87 (73.0)	5.51 (140.0)	2.13 (54.0)	3.66 (93.0)
1 1/2 (40)	1.37 (34.9)	3.50 (88.9)	6.14 (155.9)	2.40 (61.0)	3.96 (100.5)
2 (50)	1.87 (47.6)	4.00 (101.5)	6.63 (168.5)	2.83 (72.0)	4.41 (112.0)
2 1/2 (65)	2.38 (60.3)	4.53 (115.0)	7.17 (182.0)	3.58 (91.0)	5.23 (133.0)
3 (80)	2.87 (73.0)	5.57 (141.5)	8.21 (208.5)	4.41 (112.0)	5.98 (152.0)
4 (100)	3.84 (97.6)	6.98 (177.0)	9.61 (244.0)	5.20 (132.0)	6.77 (172.0)

Product Data Sheet

00813-0100-4727, Rev RA
December 2007

Rosemount 8700 Series

FIGURE 14. Dimensional Drawings of Rosemount 8721 Flowtube Sensors Typical of 1 through 4inch (25 through 100mm) line sizes

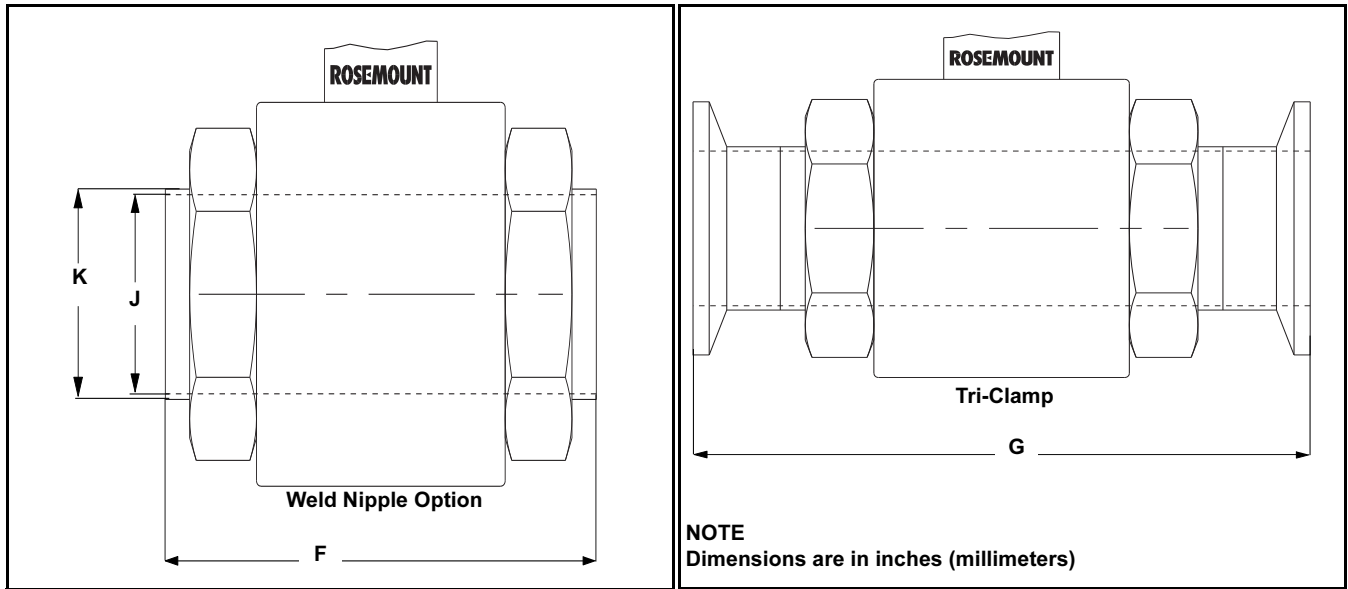

TABLE 23. Rosemount 8721 Process Connection Lay Length in Inches (Millimeters). Refer to Figure 14.

Line Size	Weld Nipple Length F	Weld Nipple Tube ID J	Weld Nipple Tube OD K	Tri Clamp Length G	HP Option Length G	DIN 11851 (Met and Imp) Length G	DIN 11851 (Met and Imp) ID J	DIN 11851 (Metric) ID J
1/2 (15)	5.61 (142)	0.62 (15.75)	0.75 (19.05)	8.31 (211)	NA	8.33 (211)	0.62 (15.75)	0.79 (19.99)
1 (25)	5.61 (142)	0.87 (22.2)	1.00 (25.65)	7.85 (199)	9.85 (250)	7.89 (200)	0.85 (21.52)	1.02 (26.01)
1 1/2 (40)	5.92 (150)	1.37 (34.9)	1.68 (42.7)	8.17 (207)	9.91 (252)	8.53 (217)	1.37 (34.85)	1.50 (38.00)
2 (50)	6.35 (161)	1.87 (47.6)	2.01 (51.05)	8.60 (218)	9.91 (252)	9.10 (231)	1.87 (47.60)	1.97 (50.01)
2 1/2 (65)	7.18 (182)	2.37 (60.3)	2.51 (63.75)	9.43 (239)	9.91 (252)	10.33 (262)	2.37 (60.30)	2.60 (65.99)
3 (80)	7.93 (201)	2.87 (73.0)	3.01 (76.45)	10.18 (258)	9.91 (252)	11.48 (291)	2.87 (72.97)	3.19 (81.03)
4 (100)	9.46 (240)	3.84 (97.6)	4.01 (101.85)	11.70 (297)	NA	13.72 (349)	3.84 (97.61)	3.94 (100.00)

Line Size	DIN 11864-1 Length G	DIN 11864-2 Length G	SMS 1145 Length G	Cherry-Burrell I-Line Length G
1/2 (15)	NA	NA	NA	NA
1 (25)	8.98 (228.0)	8.86 (225.0)	6.87 (174)	7.17 (182)
1 1/2 (40)	9.72 (247.0)	9.57 (243.0)	7.50 (190)	7.80 (198)
2 (50)	10.16 (258.0)	10.00 (254.0)	7.93 (201)	8.42 (214)
2 1/2 (65)	11.89 (302.0)	11.54 (293.0)	9.07 (230)	9.49 (241)
3 (80)	12.95 (329.0)	12.44 (316.0)	9.82 (249)	10.37 (263)
4 (100)	14.57 (370.0)	14.21 (361.0)	11.67 (296)	12.15 (309)

Rosemount 8700 Series

FIGURE 15.

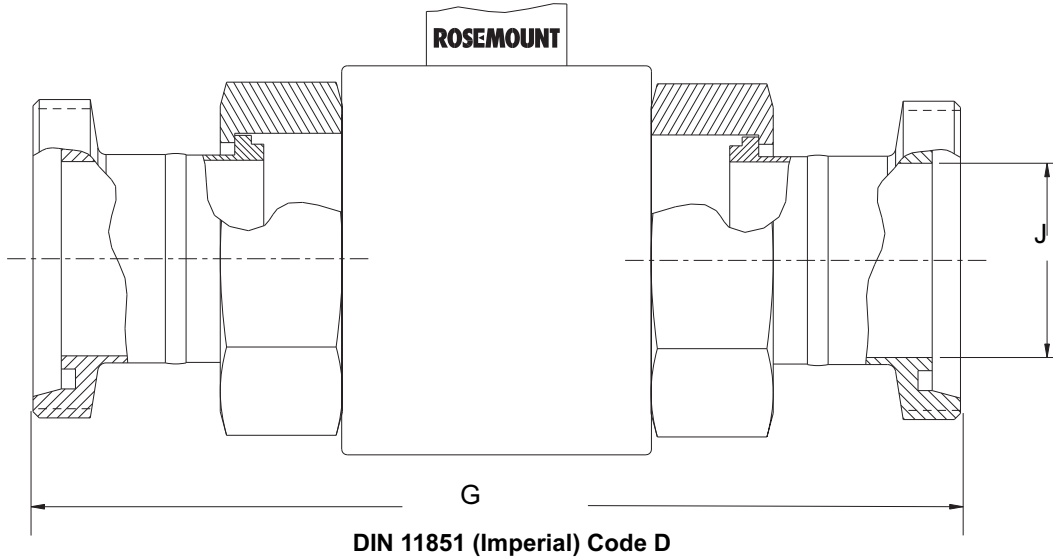

FIGURE 16.

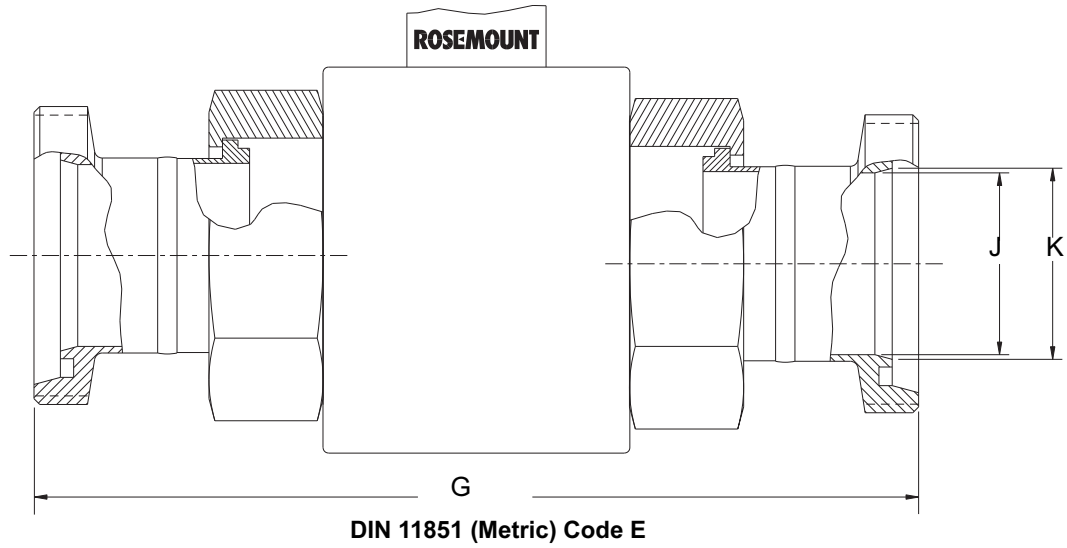

FIGURE 17.

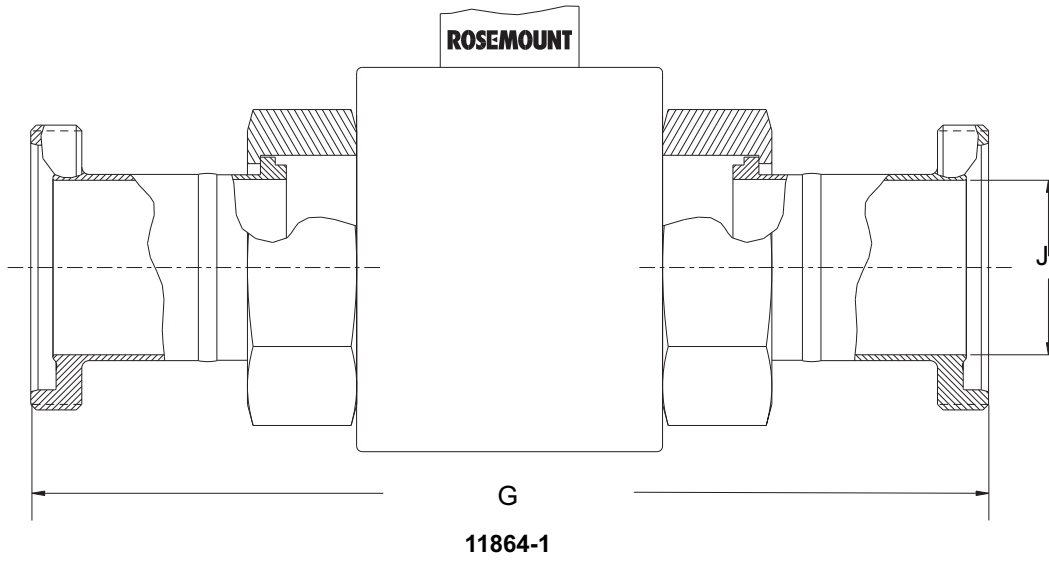
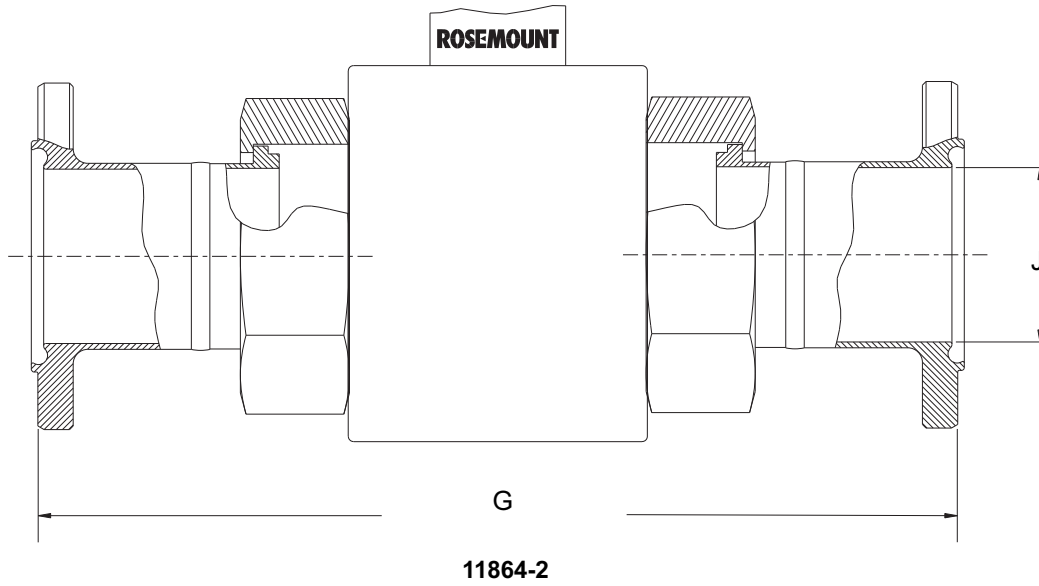
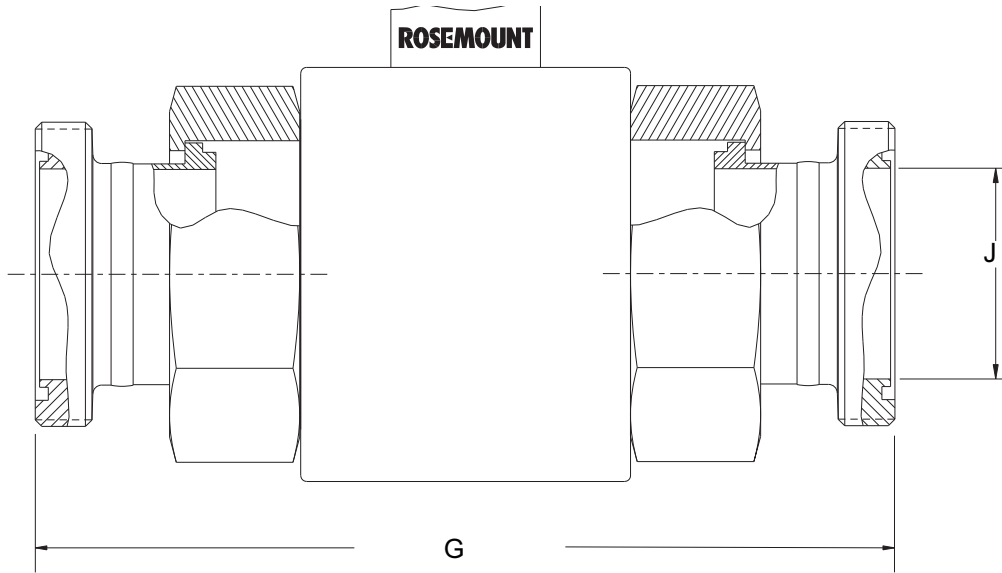

FIGURE 18.



Rosemount 8700 Series

FIGURE 19.



SMS1145 Code H

FIGURE 20.

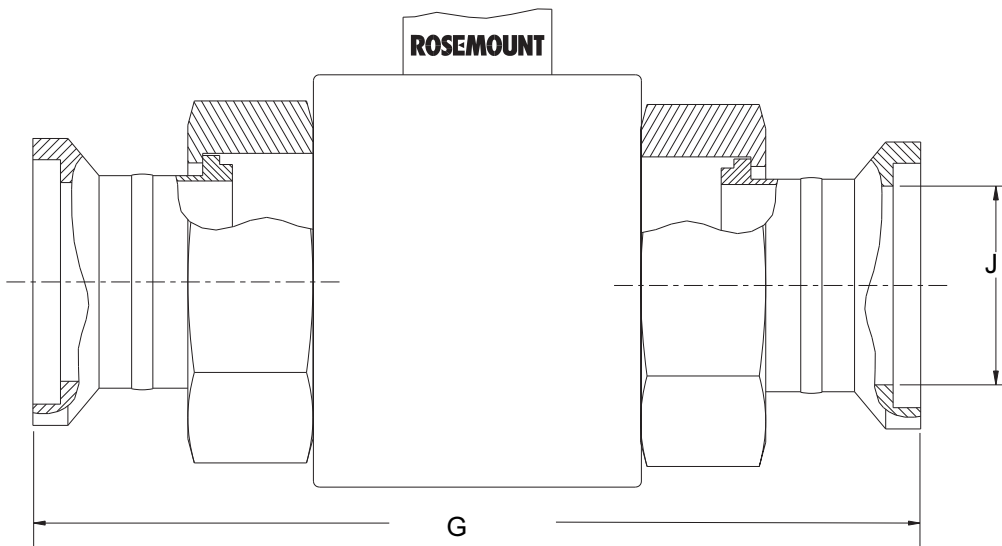

Cherry Burrell I-Line Code J

FIGURE 21. Rosemount 8714D Calibration Standard

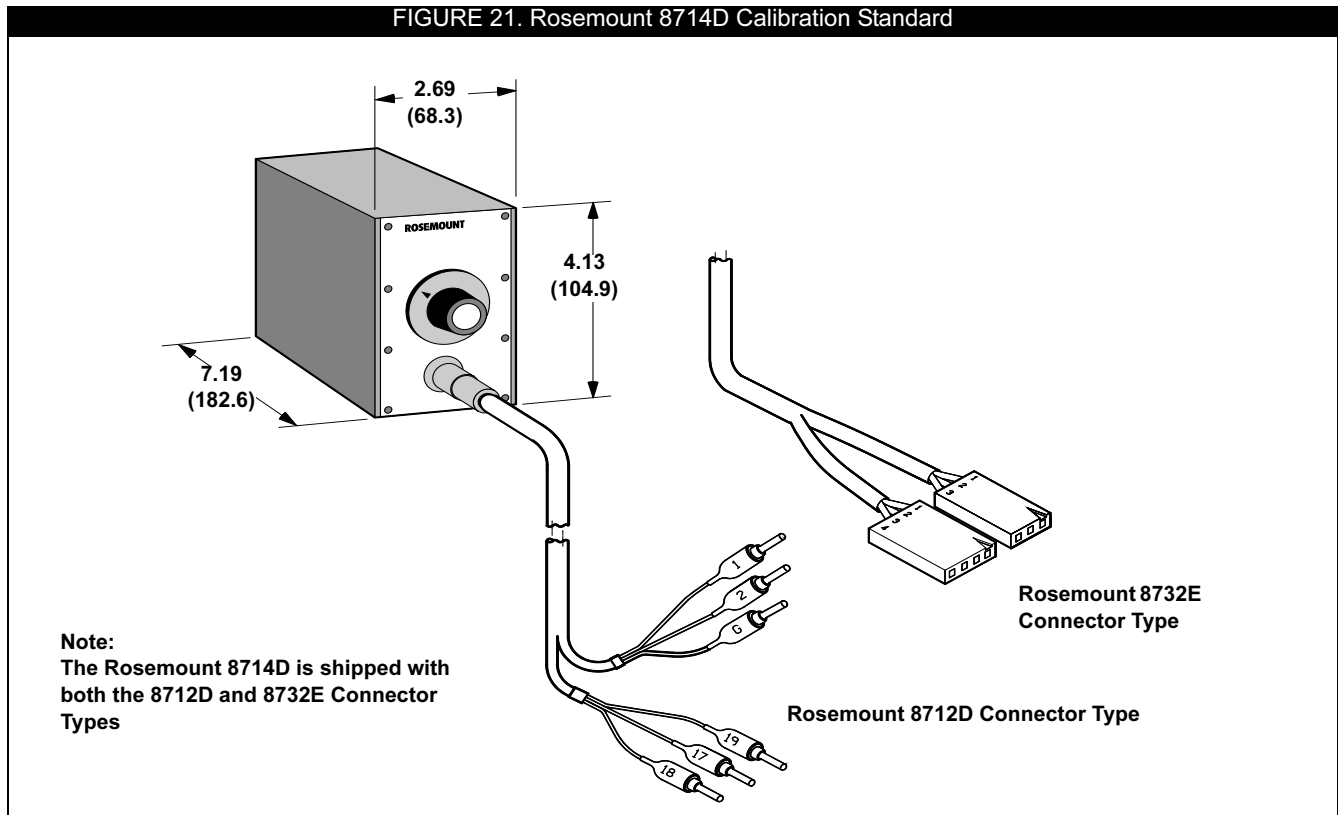

NOTE
The Rosemount 8732E Connector Type is compatible with the Rosemount 8742.

Rosemount 8700 Series

Magnetic Flowmeter Sizing

Flowmeter Sizing

Because of its effect on flow velocity, flowtube sensor size is an important consideration. It may be necessary to select a magnetic flowmeter that is larger or smaller than the adjacent piping to ensure the fluid velocity is in the specified measuring range of the flowtube sensor. Suggested guidelines and examples for sizing normal velocities in different applications are listed in Table 24, Table 25, and Table 26. Operation outside these guidelines may also give acceptable performance.

TABLE 24. Sizing Guidelines

Application	Velocity Range (ft/s)	Velocity Range (m/s)
Normal Service	2–20	0.6–6.1
Abrasive Slurries	3–10	0.9–3.1
Non-Abrasive Slurries	5–15	1.5–4.6

To convert flow rate to velocity, use the appropriate factor listed in Table 25 and the following equation:

$$\text{Velocity} = \frac{\text{Flow Rate}}{\text{Factor}}$$

Example: SI Units

Magnetometer Size: 100 mm (**factor from Table 25 = 492.0**)
Normal Flow Rate: 800 L/min

$$\text{Velocity} = \frac{800 \text{ (L/min)}}{492.0}$$

$$\text{Velocity} = 1.7 \text{ m/s}$$

Example: English Units

Magnetometer Size: 4 in. (**factor from Table 25 = 39.679**)
Normal Flow Rate: 300 GPM

$$\text{Velocity} = \frac{300 \text{ (gpm)}}{39.679}$$

$$\text{Velocity} = 7.56 \text{ ft/s}$$

TABLE 25. Line Size vs. Conversion Factor

Nominal Line Size Inches (mm)	Gallons Per Minute Factor	Liters Per Minute Factor
0.15 (4)	0.055	0.683
0.30 (8)	0.220	2.732
½ (15)	0.947	11.745
1 (25)	2.693	33.407
1½ (40)	6.345	78.69
2 (50)	10.459	129.7
3 (80)	23.042	285.7
4 (100)	39.679	492.0
6 (150)	90.048	1,116
8 (200)	155.94	1,933
10 (250)	245.78	3,048
12 (300)	352.51	4,371
14 (350)	421.70	5,229
16 (400)	550.80	6,830
18 (450)	697.19	8,645
20 (500)	866.51	10,745
24 (600)	1,253.2	15,541
30 (750)	2,006.0	24,877
36 (900)	2,935.0	36,398

Product Data Sheet

00813-0100-4727, Rev RA
December 2007

Rosemount 8700 Series

TABLE 26. Line Size vs. Velocity/Rate

Nominal Line Size in Inches (mm)	Minimum/Maximum Flow Rate							
	Gallons per Minute				Liters per Minute			
	at 0.04 ft/s (Low-flow Cutoff)	at 1 ft/s (Min Range Setting)	at 3 ft/s	at 39 ft/s (Max Range Setting)	at 0.012 m/s (Low-flow Cutoff)	at 0.3 m/s (Min Range Setting)	at 1 m/s	at 12 m/s (Max Range Setting)
.15 (4)	0.002	0.055	0.16	2.14	0.01	0.21	0.68	8.16
.30 (8)	0.009	0.220	0.66	8.58	0.03	0.83	2.73	32.76
1/2 (15)	0.038	0.947	2.84	36.93	0.14	3.58	11.74	140.88
1 (25)	0.108	2.694	8.08	105.07	0.41	10.18	33.40	424.80
1 1/2 (40)	0.254	6.345	19.03	247.46	0.96	23.98	78.69	944.28
2 (50)	0.418	10.459	31.37	407.90	1.58	39.54	129.7	1,556
3 (80)	0.922	23.042	69.12	898.64	3.49	87.10	285.7	3,428
4 (100)	1.588	36.679	119.0	1430.4	6.00	138.6	492.0	5,904
6 (150)	3.600	90.048	270.1	3511.8	13.61	340.3	1,116	13,400
8 (200)	6.240	155.94	467.7	6081.7	23.59	589.4	1,933	23,204
10 (250)	9.840	245.78	737.3	9585.4	37.20	929.0	3,048	36,576
12 (300)	14.200	352.51	1,059	13,747	53.68	1,332	4,371	52,548
14 (350)	16.800	421.70	1,265	16,446	63.50	1,594	5,230	62,755
16 (400)	22.000	550.80	1,652	21,481	83.16	2,082	6,830	81,964
18 (450)	27.800	697.19	2,091	27,190	105.0	2,635	8,646	103,750
20 (500)	34.600	866.51	2,599	33,793	130.7	3,275	10,740	128,948
24 (600)	50.200	1,253.2	3,759	48,874	189.7	4,737	15,540	186,496
30 (750)	80.200	2,006.0	6,018	78,234	303.1	7,582	24,880	298,527
36 (900)	117.40	2,935.0	8,805	114,465	443.7	11,094	36,390	436,779

Upstream/Downstream Piping Length

To ensure specification accuracy over widely varying process conditions, install the flowtube sensor with a minimum of five straight pipe diameters upstream and two straight pipe diameters downstream from the electrode plane. See Figure 22. This procedure should adequately allow for disturbances created by elbows, valves, and reducers.

Flowtube Sensor Grounding

A reliable ground path is required between the flowtube sensor and the process fluid. Optional grounding rings, grounding electrodes, and lining protectors are available with 8700 Series flowtube sensors to ensure proper grounding. See Table 31 and Table 32.

FIGURE 22. Upstream and Downstream Straight Pipe Diameters

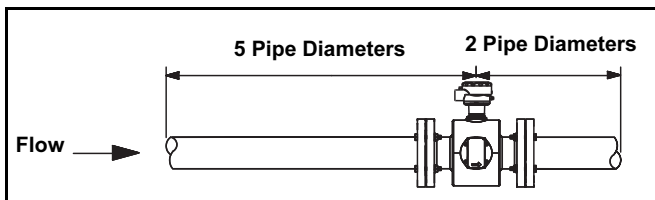

Installations with reduced straight runs from 0 to five pipe diameters are possible. In reduced straight pipe run installations, performance will shift to as much as 0.5% of rate. Reported flow rates will still be highly repeatable.

Rosemount 8700 Series

Product Selection Guide

Several flowtube sensor types, liner types, electrode materials, electrode types, grounding options, and transmitters are available for the Rosemount 8700 Series Magnetic Flowmeter System to ensure compatibility with virtually any application and installation. See Table 29 for information on liner types, Table 30 for information on electrodes materials and electrode types, Table 31 and Table 32 for grounding options and installation, and Table 27 for transmitter selection. Other material options not mentioned here are available. Contact your local sales representative for alternative material selection. For further guidance on selecting materials, refer to the Magnetic Flowmeter Material Selection Guide located on Rosemount.com (Technical Data Sheet Number 00816-0100-3033). For more information regarding product offering and ordering information, refer to “Ordering Information” on page 65 in this product data sheet.

TABLE 27. Transmitter Selection







Transmitter	General Characteristics
 <p>8732E</p>	<ul style="list-style-type: none"> • Ideal for integral mount transmitter installations • Advanced Diagnostics (DA1 and DA2 Suites) available • Optical Switch LOI • Optional DI/DO available
 <p>8712D</p>	<ul style="list-style-type: none"> • Remote mount transmitter • Easy to use LOI with dedicated configuration buttons • Advanced Diagnostics (DA1 Suite) available
 <p>8712H</p>	<ul style="list-style-type: none"> • Remote mount transmitter • High-Signal Pulsed DC for use with the High-Signal 8707 Flowtube Sensor • Ideal for noisy applications - mining/pulp stock/other slurries • 115 V AC power only • Not CE Marked
 <p>8742C</p>	<ul style="list-style-type: none"> • FOUNDATION fieldbus transmitter • Integral or remote mount • Advanced Diagnostics (D01 Suite) available

TABLE 28. Flowtube Sensor Selection

Flowtube Sensor	General Characteristics
 <p>8705</p>	<ul style="list-style-type: none"> • Standard Process Flowtube Sensor • Flanged Process Connections • Welded, sealed coil housing • 1/2-in. (15mm) to 36-in. (900mm) • Pulse DC Technology • Standard, grounding, and bulletnose electrodes available
 <p>8707</p>	<ul style="list-style-type: none"> • High Signal Flowtube Sensor • Flanged Process System Flowtube Sensor • Welded, sealed coil housing • 3-in. (80mm) to 36-in. (900mm) • High current pulsed DC technology ideal for high noise applications • Standard, grounding, and bulletnose electrodes available
 <p>8711</p>	<ul style="list-style-type: none"> • Wafer (flangeless) design • Economical, compact, and lightweight alternative to flanged flowtube sensors • 0.15-in. (4mm) to 8-in. (200mm) • Pulsed DC technology • Standard, grounding, and bulletnose electrodes available
 <p>8721</p>	<ul style="list-style-type: none"> • Hygienic flowtube sensor • Designed for food, beverage, and pharmaceutical applications • 3-A and EHEDG certified • 1/2-in. (15mm) to 4-in. (100mm) • Pulsed DC technology • Variety of industry standard process connections • Suitable for CIP/SIP

Product Data Sheet

00813-0100-4727, Rev RA

December 2007

Rosemount 8700 Series

TABLE 29. Lining Material Selection





Liner Material	General Characteristics
PFA 	<ul style="list-style-type: none"> • Best chemical resistance • Better abrasion resistance than PTFE • Best high temperature capabilities • -20 to 350°F (-29 to 177°C)
PTFE 	<ul style="list-style-type: none"> • Highly chemical resistant • Excellent high temperature capabilities • -20 to 350°F (-29 to 177°C)
ETFE 	<ul style="list-style-type: none"> • Excellent chemical resistance • Better abrasion resistance than PTFE • -20 to 300°F (-29 to 149°C)
Polyurethane 	<ul style="list-style-type: none"> • Excellent abrasion resistance for slurries with small and medium particles • Limited chemical resistance • 0 to 140°F (-18 to 60°C) • Typically applied in clean water
Neoprene 	<ul style="list-style-type: none"> • Very good abrasion resistance for small and medium particles • Better chemical resistance than polyurethane • 0 to 185°F (-18 to 85°C) • Typically applied in water with chemicals, and sea water
Linatex Rubber 	<ul style="list-style-type: none"> • Very good abrasion resistance for large particles • Limited chemical resistance especially in acids • Softer material than polyurethane and neoprene • 0 to 158°F (-18 to 70°C) • Typically applied in mining slurries

TABLE 30. Electrode Selection

Electrode Material	General Characteristics
316L Stainless Steel	<ul style="list-style-type: none"> • Good corrosion resistance • Good abrasion resistance • Not recommended for sulfuric or hydrochloric acids
Nickel Alloy 276 (UNS N10276)	<ul style="list-style-type: none"> • Better corrosion resistance • High strength • Good in slurry applications • Effective in oxidizing fluids
Tantalum	<ul style="list-style-type: none"> • Excellent corrosion resistance • Not recommended for hydrofluoric acid, fluorosilic acid, or sodium hydroxide
80% Platinum	<ul style="list-style-type: none"> • Best chemical resistance • Expensive material • not recommended for aquaregia
Titanium	<ul style="list-style-type: none"> • Better chemical resistance • Better abrasion resistance • Good for sea water applications • Not recommended for hydrofluoric or sulfuric acid
Electrode Type	General Characteristics
Standard Measurement	<ul style="list-style-type: none"> • Lowest cost • Good for most applications
Standard Measurement + Grounding (Also see Table 31 and Table 32 for grounding options and installation)	<ul style="list-style-type: none"> • Low cost grounding option especially for large line sizes • Minimum conductivity of 100 microsiemens/cm • Not recommended for electrolysis or galvanic corrosion applications
Bulletnose	<ul style="list-style-type: none"> • Slightly more expensive • Best option for coating processes

Rosemount 8700 Series

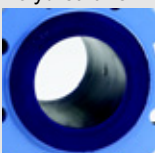
TABLE 31. Grounding Options

Grounding Options	General Characteristics
No Grounding Options (grounding straps)	<ul style="list-style-type: none"> • Acceptable for conductive unlined pipe • Grounding straps provided at no cost
Grounding Electrodes	<ul style="list-style-type: none"> • Same material as measurement electrodes • Sufficient grounding option when process fluid conductivity is greater than 100 microsiemens/cm • Not recommended in electrolysis applications, galvanic corrosion applications, or applications where the electrodes may coat.
Grounding Rings	<ul style="list-style-type: none"> • Low conductivity process fluids • Cathodic or electrolysis applications that may have stray currents in or around the process • Variety of materials for process fluid compatibility
Lining Protectors	<ul style="list-style-type: none"> • Protect upstream edge of flowtube sensor from abrasive fluids • Permanently installed on flowtube sensor • Protect liner material from over torquing of flange bolts • Provide ground path and eliminate need for grounding rings or grounding electrode

TABLE 32. Grounding Installation

Type of Pipe	Grounding Options			
	No Grounding Option (Straps Only)	Grounding Rings	Grounding Electrode	Lining Protectors
Conductive Unlined Pipe	Acceptable	Not Required	Not Required	Acceptable (Not Required)
Conductive Lined Pipe	Not Acceptable	Acceptable	Acceptable	Acceptable
Non-Conductive Pipe	Not Acceptable	Acceptable	Acceptable	Acceptable

Ordering Information

ROSEMOUNT 8732E ORDERING INFORMATION

Model	Product Description
8732E	Magnetic Flowmeter Transmitter
Code	Transmitter Style
S	Standard
Code	Transmitter Mount
T	Integral Mount
R	Remote Mount for 2 in. pipe or panel (includes CS mounting bolts and 316L SST bracket)
Code	Transmitter Power Supply
1	AC Power Supply (90 to 250 V AC, 50-60Hz)
2	DC Power Supply (12 to 42 V DC)
Code	Outputs
A	4-20 mA Digital Electronics (HART Protocol)
B	4-20 mA Digital Electronics (HART Protocol) with Intrinsically Safe Output ⁽¹⁾
Code	Conduit Entry
	2 Conduits
1	¹ / ₂ - 14 NPT, 2 Conduit Entries
2	CM20, 2 Conduit Entries ⁽²⁾
3	PG 13.5, 2 Conduit Entries ⁽²⁾
	3 Conduits
4	¹ / ₂ - 14 NPT, 3 Conduit Entries
5	CM20, 3 Conduit Entries ⁽²⁾
6	PG 13.5, 3 Conduit Entries ⁽²⁾
Code	Safety Approvals ⁽³⁾
NA	CE Marking, no hazardous location approval
	FM & CSA
N0	FM Class 1 Div 2 for non-flammable: CSA Class 1 Div 2
N5	FM Class 1 Div 2 for flammable fluids
E5	FM Class 1 Div 1, explosion-proof
	ATEX
E1	ATEX flameproof Ex de IIC, and ATEX Dust Approval
ED	ATEX flameproof Ex de IIB T6, and ATEX Dust Approval
N1	ATEX Type n Ex nA nL IIC and ATEX Dust Approval ⁽⁴⁾
ND	ATEX Dust Approval
	IECEX
E7	IECEX flameproof Ex de IIC, and IECEX Dust Approval
EF	IECEX flameproof Ex de IIB T6, and IECEX Dust Approval
N7	IECEX Type n Ex nA nL IIC and IECEX Dust Approval ⁽⁴⁾
NF	IECEX Dust Approval

Continued On Next Page

Rosemount 8700 Series

Code	Options
	PlantWeb Product/Process Diagnostics
DA1	Magmeter HART Diagnostic Suite 1: Includes High Process Noise and Ground/Wiring Fault Detection
DA2	Magmeter HART Diagnostic Suite 2: Includes 8714i Calibration Verification
	Discrete Input/Discrete Output
AX	DI/DO, see page 11 for more details ⁽⁵⁾ ⁽⁶⁾
	Other Options
C1	Custom Configuration (CDS Required)
D1	High Accuracy Calibration (0.15% of rate for matched tube and transmitter) ⁽⁷⁾
DT	Heavy Duty Tagging
M4	Local Operator Interface
B6	316L Stainless Steel 4-bolt Kit for 2-in. Remote Pipe Mount
GE	M12, 4-Pin, Male Connector (Eurofast)
GM	A Size Mini, 4-Pin, Male Connector (Minifast)
GT	A Size, Spade Terminal Mini, 5-pin, Male Connector (Minifast)
C4	Analog Output Levels Compliant with NAMUR Recommendations NE43, 18-January-1994, and High Alarm Level
CN	Analog Output Levels Compliant with NAMUR Recommendations NE43, 18-January-1994, and Low Alarm Level
	QIG Language
YA	Danish
YD	Dutch
YF	French
YG	German
YH	Finnish
YI	Italian
YN	Norwegian
YP	Portuguese
YS	Spanish
YR	Russian
YW	Swedish
Typical Model Number: 8732E S T 1 A 1 N0 DA1 DA2 M4	

- (1) I.S. Output must be externally powered
- (2) Adapter are used for this conduit entry type
- (3) All product, ordered with or without Safety approvals, is compliant with local CE Marking and C-tick requirements unless specifically noted as a special
- (4) For DC Transmitter Power Supply (Code = 2) Only
- (5) Not available with intrinsically safe outputs (output option B)
- (6) Not available with conduit entry codes 1, 2 or 3
- (7) D1 Option Code must be ordered with flowtube sensor and transmitter

Product Data Sheet

00813-0100-4727, Rev RA

December 2007

Rosemount 8700 Series

ROSEMOUNT 8712D ORDERING INFORMATION

Model	Product Description
8712D	Magnetic Flowmeter Transmitter
Code	Transmitter Style
R	Remote (2-in. pipe or surface mounting)
Code	Power Supply Voltage
03	12–42 V DC
12	90–250 V AC, 50–60 Hz
Code	Product Certifications
NA	No Hazardous Area Approval; CE Marking
	FM & CSA
N0	Factory Mutual (FM) Class I, Division 2 Approval for nonflammable fluids; Canadian Standards Association (CSA) Class I, Division 2 Approval; CE Marking
N5	Factory Mutual (FM) Class I, Division 2 Approval for flammable fluids
	ATEX
N1	ATEX Type n Ex nA nL IIC and ATEX Dust Approval ⁽¹⁾
Code	Options
DA1	Magmeter HART Diagnostic Suite 1: Includes High Process Noise, Ground/Wiring Fault Detection, and Transmitter Verification
B6	Stainless Steel 4-bolt Kit for 2-in. Pipe Mount
C1	Custom Configuration (Completed CDS required with order)
C4	Analog Output Levels Compliant with NAMUR recommendations NE43, 18-January-1994, and high alarm level ⁽²⁾
CN	Analog Output Levels Compliant with NAMUR recommendations NE43, 18-January-1994, and low alarm level ⁽²⁾
D1	High Accuracy Calibration (0.15% of rate for matched tube and transmitter) ⁽³⁾
M4	Local Operator Interface (LOI)
J1	CM 20 conduit adapter
J2	PG 13.5 conduit adapter
Code	Quick Installation Guide (QIG) Language Options (Default is English)
YA	Danish QIG
YD	Dutch QIG
YF	French QIG
YG	German QIG
YH	Finnish QIG
YI	Italian QIG
YN	Norwegian QIG
YP	Portuguese QIG
YR	Russian QIG
YS	Spanish QIG
YW	Swedish QIG
Typical Model Number: 8712D R 12 N 0 M 4	

(1) For DC Transmitter Power Supply (Code = 03) Only

(2) NAMUR compliant operation and the Alarm latch options are preset at the factory and can not be changed to standard operation in the field

(3) D1 Option Code must be ordered with flowtube sensor and transmitter

Rosemount 8700 Series

ROSEMOUNT 8712H ORDERING INFORMATION

Model	Product Description
8712H	High-Signal Magnetic Flowmeter Transmitter (For use with 8707 High-Signal Flowtube Sensor only.)
Code	Transmitter Style
R	Remote (2-in. pipe or surface mounting)
Code	Power Supply Voltage
12	115 V AC, 50–60 Hz
Code	Product Certifications
N0	Factory Mutual (FM) Class I, Division 2 Approval for nonflammable fluids; Canadian Standards Association (CSA) Class I, Division 2 Approval
N5	Factory Mutual (FM) Class I, Division 2 Approval for flammable fluids
Code	Options
B6	Stainless Steel 4-bolt Kit for 2-in. Pipe Mount
C1	Custom Configuration (Completed CDS required with order)
D1	High Accuracy Calibration [0.25% of rate from 3 to 30 ft/s (0.9 to 10 m/s)] matched flowtube sensor and transmitter system ⁽¹⁾
M4	Local Operator Interface (LOI)
Code	Quick Installation Guide (QIG) Language Options (Default is English)
YA	Danish QIG
YD	Dutch QIG
YF	French QIG
YG	German QIG
YH	Finnish QIG
YI	Italian QIG
YN	Norwegian QIG
YP	Portuguese QIG
YS	Spanish QIG
YW	Swedish QIG
Typical Model Number: 8712H R 12 N 0 M 4	

(1) D1 Option Code must be selected for both flowtube sensor and transmitter.

Product Data Sheet

00813-0100-4727, Rev RA

December 2007

Rosemount 8700 Series

ROSEMOUNT 8742C ORDERING INFORMATION

Model	Product Description
8742C	Magnetic Flowmeter Transmitter with FOUNDATION fieldbus (flowtube sensor ordered separately)
Code	Transmitter Output
F	FOUNDATION fieldbus protocol, comes with standard Analog Input Integrator Function block and Backup LAS
Code	Power Supply Voltage
AC	90–250 V AC, 50–60 Hz
DC	15-50 V DC
Code	Product Certifications
N0	Factory Mutual (FM) Class I, Division 2, Class II/III Division 1, approval for nonflammable fluids; Canadian Standards Association (CSA) Class I, Division 2 Approval CE Marking;
NA	No Hazardous Area Approval; CE Marking
N5	Factory Mutual (FM) Class I, Division 2, Class II/III Division 1, approval for flammable fluids
E1	ATEX EEx d IIB + H2 T6, Flameproof Approval for Hydrogen gas
E5 ⁽¹⁾	Factory Mutual (FM) Class I, Division 1, Class II/III Division 1, explosion proof approval
ED	ATEX EEx d IIB T6, Flame-proof approval
K0	Factory Mutual (FM) Class I, Division 2, Class II/III Division 1, approval and Canadian Standards Association (CSA) Class 1, Division 2, Class II/III Division 1 with intrinsically safe fieldbus output
K1	ATEX EEx de [ia] IIB + H2 T6 flameproof approval for hydrogen gas with intrinsically safe fieldbus output and FISCO compliant
K5 ⁽¹⁾	Factory Mutual (FM) Class I, Division 1, Explosion Proof with intrinsically safe fieldbus and FISCO output
KD	ATEX EEx d [ia] IIB T6, Flame-proof approval with intrinsically safe fieldbus output and FISCO compliant
Code	Options
	PlantWeb Software Functions
D01	Product and process diagnostics: grounding/wiring diagnostic, electrode fault diagnostic, and high process noise detection ⁽²⁾
D11	Product diagnostic: grounding/wiring diagnostic and electrode fault diagnostic ⁽²⁾
D21	Process diagnostic: high process noise detection ⁽²⁾
	Transmitter Options
B4	Remote Mount for 2" Pipe Mount Bracket (transmitter junction box, 316L SST mounting bracket, and galvanized bolts included)
B6	Remote Mount for 2" Pipe Mount Bracket (transmitter junction box, 316L SST mounting bracket and bolts included)
C1	Custom Configuration (completed configuration data sheet (CDS) required with order)
D1	High Accuracy Calibration (0.2% of rate for matched tube and transmitter) ⁽³⁾
DT	Heavy Duty Tagging
J1	CM 20 Conduit Adapter
J2	PG 13.5 Conduit Adapter
M5	Local Display
	Conduit Electrical Connector
GE ⁽⁴⁾	M12, 4-pin, Male Connector (<i>Eurofast</i> [®])
GM ⁽⁴⁾	A size Mini, 4-pin, Male Connector (<i>Minifast</i> [®])
GN ⁽⁴⁾	GM with EEx d

Continued on Next Page

Rosemount 8700 Series

Code	Quick Installation Guide (QIG) Language Options (Default is English)
YA	Danish QIG
YD	Dutch QIG
YF	French QIG
YG	German QIG
YH	Finnish QIG
YI	Italian QIG
YN	Norwegian QIG
YP	Portuguese QIG
YR	Russian QIG
YS	Spanish QIG
YW	Swedish QIG

Typical Model Number: 8742C F AC N 0 D 0 1

- (1) Only available with Rosemount 8711 Integral Mount flowtube sensor
- (2) Only one diagnostic selection can be specified for the 8742C transmitter.
- (3) D1 Option Code must be ordered with flowtube sensor and transmitter
- (4) Not available with certain hazardous location certifications. Contact a Rosemount representative for details

ROSEMOUNT 8705 ORDERING INFORMATION

Code	Product Description						Availability
8705	Magnetic Flowmeter Flowtube Sensor						•
Code	Lining Material						
A	PFA ⁽¹⁾						•
T	PTFE ⁽²⁾						•
F	ETFE ⁽³⁾						•
P	Polyurethane ⁽⁴⁾						•
N	Neoprene ⁽⁵⁾						•
L	Linatex ⁽⁶⁾						•
Code	Electrode Material						
S	316L Stainless Steel						•
H	Nickel Alloy 276 (UNS N10276)						•
T	Tantalum						•
P	80% Platinum - 20% Iridium						•
N	Titanium						•
Electrode Material (From Above)							
Code	Electrode Type	Code S	Code H	Code T	Code P	Code N	
A	2 Electrodes - Standard	•	•	•	•	•	
B	2 Electrodes - Bullet Nose	•	•				
E	3rd Grounding Electrode	•	•	•	•	•	
Lining Material (From Above)							
Code	Line Size	Code A	Code T	Code F	Code P	Code N and L	
005	1/2 in	•	•	•	NA	NA	
010	1 in	•	•	•	•	•	
015	1 1/2 in	•	•	•	•	•	
020	2 in.	•	•	•	•	•	
030	3 in.	•	•	•	•	•	
040	4 in.	•	•	•	•	•	
060	6 in.	•	•	•	•	•	
080	8 in.	•	•	•	•	•	
100	10 in.	•	•	•	•	•	
120	12 in.	•	•	•	•	•	
140	14 in	•	•	•	•	•	
160	16 in.	NA	•	•	•	•	
180	18 in	NA	•	NA	•	•	
200	20 in	NA	•	NA	•	•	
240	24 in	NA	•	NA	•	•	
300	30 in	NA	•	NA	•	•	
360	36 in	NA	•	NA	•	•	
Code	Flange Material and Type						
C	Carbon Steel Raised Face Slip-On						
S	Stainless Steel (304) Raised Face Slip-On						
P	Stainless Steel (316) Raised Face Slip-On						

Continued on Next Page

Rosemount 8700 Series

Code Flange Type and Rating		Availability	
1	ASME B16.5 ANSI Class 150 (30 and 36 in. AWWA C207 Table 2 Class D Flat Face)	Refer to Table 33 on page 74 for Flange Material Code C Refer to Table 34 on page 74 for Flange Material Codes S and P	
2	MSS SP44 Class 150 (30 and 36 in. line sizes only)		
3	ASME B16.5 (ANSI) Class 300		
6	ASME B16.5 (ANSI) Class 600 (Maximum Pressure: 1000 psig) ⁽⁷⁾		
7	ASME B16.5 (ANSI) Class 600 ⁽⁸⁾		
9	ASME B16.5 (ANSI) Class 900 ⁽⁸⁾⁽⁹⁾		
D	EN 1092-1 (DIN) PN 10		Refer to Table 35 on page 75 for Flange Material Code C and S (Not available with Flange Material Code P)
E	EN 1092-1 (DIN) PN 16		
F	EN 1092-1 (DIN) PN 25		
H	EN 1092-1 (DIN) PN 40		
K	AS2129 Table D ⁽¹⁰⁾		
L	AS2129 Table E ⁽¹⁰⁾		
Code Electrode Housing Configuration			
W0	Sealed, Welded Housing ⁽¹¹⁾		
W1	Sealed, Welded Housing with Pressure Relief		
W3	Sealed, Welded Housing with Separate Electrode Compartments		
Code Hazardous Area Approvals			
NA	CE Marked, No Hazardous Area Approval		
FM & CSA			
N0	FM Class 1 Div 2 for Non-Flammable fluids; CSA Class 1 Div 2		
N5	FM Class 1 Div 2 for Flammable fluids		
E5 ⁽¹²⁾	FM Class 1 Div 1, Explosion Proof		
ATEX			
E1	ATEX Ex e ia IIC T3... T6, Increased Safety Approval (with I.S. electrodes)		
KD	ATEX Ex e ia IIB T3... T6, Increased Safety Approval (with I.S. electrodes)		
N1	ATEX Ex nA [L] IIC Type n Approval		
ND	ATEX Dust Approval		
Code Options			
Certifications			
PD	Pressure Equipment Directive Certification (PED, per 97/23/EC)		
DW	NSF Drinking Water Certification ⁽¹³⁾		
Optional Grounding Rings⁽¹⁴⁾			
G1	(2) 316L SST Ground Rings		
G2	(2) Nickel Alloy 276 (UNS N10276) Ground Rings ⁽¹⁵⁾		
G3	(2) Titanium Ground Rings ⁽¹⁵⁾		
G4	(2) Tantalum Ground Rings ⁽¹⁶⁾		
G5	(1) 316L SST Ground Rings		
G6	(1) Nickel Alloy 276 (UNS N10276) Ground Rings ⁽¹⁵⁾		
G7	(1) Titanium Ground Rings ⁽¹⁵⁾		
G8	(1) Tantalum Ground Rings ⁽¹⁶⁾		

Continued on Next Page

Optional Lining Protectors⁽¹⁴⁾	
L1	(2) 316L SST Lining Protectors
L2	(2) Nickel Alloy 276 (UNS N10276) Lining Protectors ⁽¹⁵⁾
L3	(2) Titanium Lining Protectors ⁽¹⁵⁾
H1	Lay-length matching 8701 using spool piece ⁽¹⁵⁾
H2	Lay-length matching 8701 ⁽¹⁷⁾
H5	Lay-length matching Foxboro 2800 using spool piece ⁽¹⁸⁾
H7	Lay-length ABB CopaX and MagX using spool piece ⁽¹⁵⁾
Other Options	
B3	Integral Mount with 8732 and 8742
D1	High Accuracy Calibration (0.15% of rate for matched tube and transmitter) ⁽¹⁹⁾
DT	Heavy Duty Tagging
TA	High Temperature Permeable Fluid Option (Contains vent holes provided for permeable fluids such as nitric acid, hydrofluoric acid, or sodium hydroxide at high temperatures)
Q4	Calibration Certificate per ISO 10474 3.1B
Q8	Material Traceability 3.1B
Q9	Material Traceability Electrode only 3.1B
Q66	Welding Procedure Qualification Record Documentation
Q67	Welding Performance Qualification Record Documentation
Q70	Weld Examination Inspection Certificate, ISO 10474 3.1B
Typical Model Number: 8705 T SA 040 C1 W0 N0	

- (1) Available in 1/2 in. to 12 in. line sizes ANSI 150, ANSI 300, and DIN Flanges. Available in 14 in. ANSI 150 only. Not available with electrode housing code W3.
- (2) Available in 1/2 in. to 36 in. line sizes ANSI 150, ANSI 300, and DIN Flanges. Available in 1 in. to 10 in. ANSI 600 Derated only.
- (3) Available in 1/2 in. to 14 in. line sizes ANSI 150, ANSI 300, and DIN Flanges. Available in 16 in. ANSI 150 only. Available in 1 to 10 in. ANSI 600 Derated only.
- (4) Available in 1 in. to 24 in. line sizes ANSI 150, ANSI 300, and DIN Flanges. Available in 30 and 36 in. AWWA Class 125 and ANSI 150. Available in 1 in. to 24 in. ANSI 600 full rated. Available in 1 to 12 in. ANSI 900, ANSI 1500, and ANSI 2500.
- (5) Available in 1 in. to 24 in. line sizes ANSI 150, ANSI 300, and DIN Flanges. Available in 30 and 36 in. ANSI 150 only. Available in 1 to 24 in. ANSI 600 full rated. Available in 1 in. to 12 in. ANSI 900 only.
- (6) Available in 1 in. to 24 in. line sizes ANSI 150, ANSI 300, and DIN Flanges. Available in 30 and 36 in. AWWA Class 125 and ANSI 150. Available in 1 to 24 in. ANSI 600 full rated. Available in 1 in. to 12 in. ANSI 900 only.
- (7) Electrode type options limited to two measurement electrodes or two measurement electrodes + third grounding electrode
- (8) Electrode type options limited to two measurement electrodes only
- (9) Lining protectors not available
- (10) Liner material options limited to T, P, or F; cannot be ordered with ground rings, lining protectors, or H(x) options
- (11) Available with ANSI 150, ANSI 300, and DIN flanges.
- (12) Available in flowtube sensor line sizes 0.5 through 8 in. (15 through 200 mm)
- (13) Only available with PTFE (all line sizes) or Polyurethane (4 in. and larger) Liner Materials with 316L SST Electrode Material
- (14) Grounding Rings and Lining Protectors provide the same fluid grounding function. Lining Protectors available in PTFE and ETFE only
- (15) Available in flowtube sensor line sizes 0.5 through 12 in. (15 through 300 mm)
- (16) Available in flowtube sensor line sizes 0.5 through 8 in. (15 through 200 mm)
- (17) Available in flowtube sensor line sizes 0.5 through 16 in. (15 through 400 mm)
- (18) Available in flowtube sensor line sizes 3 through 18 in. (80 through 450 mm)
- (19) D1 Option Code must be ordered with flowtube sensor and transmitter

Rosemount 8700 Series

TABLE 33. Rosemount 8705 Carbon Steel ASME B16.5 (ANSI) Flange Rating Availability

Line Size Code	Line Size	Class 150 (C1)	Class 150 (C2)	Class 300 (C3)	Class 600 (C6)	Class 600 (C7)	Class 900 (C9)	Class 1500 (JM)	Class 2500 (JN)
	Inches (mm)								
005	0.5 (15)	•	NA	•	•	NA	NA	NA	NA
010	1 (25)	•	NA	•	•	•	•	•	•
015	1.5 (40)	•	NA	•	•	•	•	•	•
020	2 (50)	•	NA	•	•	•	•	•	•
030	3 (80)	•	NA	•	•	•	•	•	•
040	4 (100)	•	NA	•	•	•	•	•	•
060	6 (150)	•	NA	•	•	•	•	•	•
080	8 (200)	•	NA	•	•	•	•	•	•
100	10 (250)	•	NA	•	•	•	•	•	•
120	12 (300)	•	NA	•	NA	•	•	•	•
140	14 (350)	•	NA	•	NA	•	NA	NA	NA
160	16 (400)	•	NA	•	NA	•	NA	NA	NA
180	18 (450)	•	NA	•	NA	•	NA	NA	NA
200	20 (500)	•	NA	•	NA	•	NA	NA	NA
240	24 (600)	•	NA	•	NA	•	NA	NA	NA
300 ⁽¹⁾	30 (750)	•	•	NA	NA	NA	NA	NA	NA
360 ⁽¹⁾	36 (900)	•	•	NA	NA	NA	NA	NA	NA

(1) AWWA C207 Table 2 Class D Flat Face Flange for option C1 Only

TABLE 34. Rosemount 8705 Stainless Steel ASME B16.5 (ANSI) Flange Rating Availability

Line Size Code	Line Size	Class 150 (S1)	Class 150 (S2)	Class 300 (S3)	Class 600 (S6)	Class 600 (S7)	Class 900 (S9)	Class 150 (P1)	Class 150 (P2)	Class 300 (P3)
	Inches (mm)									
005	0.5 (15)	•	NA	•	•	NA	NA	•	NA	•
010	1 (25)	•	NA	•	•	•	•	•	NA	•
015	1.5 (40)	•	NA	•	•	•	•	•	NA	•
020	2 (50)	•	NA	•	•	•	•	•	NA	•
030	3 (80)	•	NA	•	•	•	•	•	NA	•
040	4 (100)	•	NA	•	•	•	•	•	NA	•
060	6 (150)	•	NA	•	•	•	•	•	NA	•
080	8 (200)	•	NA	•	•	•	•	•	NA	•
100	10 (250)	•	NA	•	•	•	•	•	NA	•
120	12 (300)	•	NA	•	NA	•	•	•	NA	•
140	14 (350)	•	NA	•	NA	•	NA	•	NA	•
160	16 (400)	•	NA	•	NA	•	NA	•	NA	•
180	18 (450)	•	NA	•	NA	•	NA	•	NA	•
200	20 (500)	•	NA	•	NA	•	NA	•	NA	•
240	24 (600)	•	NA	•	NA	•	NA	•	NA	•
300 ⁽¹⁾	30 (750)	•	•	NA	NA	NA	NA	•	•	NA
360 ⁽¹⁾	36 (900)	•	•	NA	NA	NA	NA	•	•	NA

(1) AWWA C207 Table 2 Class D Flat Face Flange for option S1 or P1 Only

TABLE 35. Rosemount 8705 EN 1092-1 (DIN) Flange Rating Availability

Line Size Code	Line Size Inches (mm)	Carbon Steel PN 10 (CD)	Carbon Steel PN 16 (CE)	Carbon Steel PN 25 (CF)	Carbon Steel PN 40 (CH)	Carbon Steel Table D (CK)	Carbon Steel Table E (CL)	Stainless Steel PN 10 (SD)	Stainless Steel PN 16 (SE)	Stainless Steel PN 25 (SF)	Stainless Steel PN 40 (SH)
005	0.5 (15)	NA	NA	NA	•	•	•	NA	NA	NA	•
010	1 (25)	NA	NA	NA	•	•	•	NA	NA	NA	•
015	1.5 (40)	NA	NA	NA	•	•	•	NA	NA	NA	•
020	2 (50)	NA	NA	NA	•	•	•	NA	NA	NA	•
030	3 (80)	NA	NA	NA	•	•	•	NA	NA	NA	•
040	4 (100)	NA	•	NA	•	•	•	NA	•	NA	•
060	6 (150)	NA	•	NA	•	•	•	NA	•	NA	•
080	8 (200)	•	•	•	•	•	•	•	•	•	•
100	10 (250)	•	•	•	•	•	•	•	•	•	•
120	12 (300)	•	•	•	•	•	•	•	•	•	•
140	14 (350)	•	•	•	•	•	•	•	CF	CF	CF
160	16 (400)	•	•	•	•	•	•	•	CF	CF	CF
180	18 (450)	•	•	•	•	•	•	•	CF	CF	CF
200	20 (500)	•	•	•	•	•	•	•	CF	CF	CF
240	24 (600)	•	•	•	•	•	CF	•	CF	CF	CF

Rosemount 8700 Series

ROSEMOUNT 8707 ORDERING INFORMATION

Code	Product Description						Availability
8707	High-Signal Magnetic Flowmeter Flowtube Sensor						•
Code	Lining Material						
A	PFA						•
T	PTFE						•
F	ETFE						•
P	Polyurethane						•
N	Neoprene						•
L	Linatex						•
Code	Electrode Material						
S	316L Stainless Steel						•
H	Nickel Alloy 276 (UNS N10276)						•
T	Tantalum						•
P	80% Platinum - 20% Iridium						•
N	Titanium						•
Electrode Material (From Above)							
Code	Electrode Type	Code S	Code H	Code T	Code P	Code N	
A	2 Electrodes - Standard	•	•	•	•	•	
B	2 Electrodes - Bullet Nose	•	•				
E	3rd Grounding Electrode ⁽¹⁾	•	•	•	•	•	
Lining Material (From Above)							
Code	Line Size	Code A	Code T	Code F	Code P	Code N and L	
030	3 in.	•	•	•	•	•	
040	4 in.	•	•	•	•	•	
060	6 in.	•	•	•	•	•	
080	8 in.	•	•	•	•	•	
100	10 in.	•	•	•	•	•	
120	12 in.	•	•	•	•	•	
140	14 in.	NA	•	•	•	•	
160	16 in.	NA	•	•	•	•	
180	18 in.	NA	•	NA	•	•	
200	20 in.	NA	•	NA	•	•	
240	24 in.	NA	•	NA	•	•	
300	30 in.	NA	•	NA	•	•	
360	36 in.	NA	•	NA	•	•	
Code	Flange Material						
C	Carbon Steel						
S	Stainless Steel (304)						
Code	Flange Type and Rating						Availability
1	ASME B16.5 (ANSI) RF Class 150						
2	MSS SP44 Class 150						
3	ASME B16.5 (ANSI) RF Class 300						
Code	Electrode Housing Configuration						
W0	Sealed, Welded Housing						
W1	Sealed, Welded Housing with Pressure Relief						
W3	Sealed, Welded Housing with Separate Electrode Compartments						
Code	Hazardous Area Approvals						
NA	No Hazardous Area Approval Required; CE Marking						
N0	FM Class 1 Div 2 for Non-Flammable fluids; CSA Class 1 Div 2						
N5	FM Class 1 Div 2 for Flammable fluids						

Continued on Next Page

Product Data Sheet

00813-0100-4727, Rev RA

December 2007

Rosemount 8700 Series

Code	Options
	Optional Grounding Rings⁽²⁾
G1	(2) 316L SST Ground Rings
G2	(2) Nickel Alloy 276 (UNS N10276) Ground Rings ⁽³⁾
G3	(2) Titanium Ground Rings ⁽³⁾
G4	(2) Tantalum Ground Rings ⁽⁴⁾
G5	(1) 316L SST Ground Rings
G6	(1) Nickel Alloy 276 (UNS N10276) Ground Rings ⁽³⁾
G7	(1) Titanium Ground Rings ⁽³⁾
G8	(1) Tantalum Ground Rings ⁽⁴⁾
	Optional Lining Protectors⁽²⁾
L1	(2) 316L SST Lining Protectors
L2	(2) Nickel Alloy 276 (UNS N10276) Lining Protectors ⁽³⁾
L3	(2) Titanium Lining Protectors ⁽³⁾
	Other Options
H1	Lay-length matching 8701 using spool piece ⁽³⁾
H2	Lay-length matching 8701 ⁽⁵⁾
H5	Lay-length matching Foxboro 2800 using spool piece ⁽⁶⁾
H7	Lay-length ABB Copax and MagX using spool piece ⁽³⁾
B3	Integral Mount with 8732 and 8742
D1	High Accuracy Calibration ⁽⁷⁾
D2	Dual Flowtube Sensor Calibration Numbers for Rosemount 8732E, 8712D, and 8742C Transmitters
DT	Heavy Duty Tagging
Q4	Calibration Certificate per ISO 10474 3.1B
Q8	Material Traceability 3.1B
Q9	Material Traceability Electrode only 3.1B
Q66	Welding Procedure Qualification Record Documentation
Q67	Welding Performance Qualification Record Documentation
Q70	Weld Examination Inspection Certificate, ISO 10474 3.1B
Typical Model Number: 8707 T SA 040 C1 W0 N0	

(1) Available for 10 in. (250 mm) and larger line size only

(2) Grounding Rings and Lining Protectors provide the same fluid grounding function. Lining Protectors available in PTFE and ETFE only

(3) Available in flowtube sensor line sizes 3 through 12 in. (15 through 300 mm)

(4) Available in flowtube sensor line sizes 3 through 8 in. (15 through 200 mm)

(5) Available in flowtube sensor line sizes 3 through 16 in. (15 through 400 mm)

(6) Available in flowtube sensor line sizes 3 through 18 in. (15 through 450 mm)

(7) D1 Option Code must be ordered with flowtube sensor and transmitter. Accuracy with 8712H transmitter is 0.25% of rate from 3 to 30 ft/sec (1 to 10 m/sec). Accuracy with 8732E or 8712D transmitters is 0.15% of rate. Accuracy with 8742C transmitter is 0.2% of rate.

Rosemount 8700 Series

TABLE 36. Rosemount 8707 ASME B16.5 (ANSI) Flange Rating Availability

Line Size Code	Line Size Inches (mm)	Carbon Steel Class 150 (C1)	Carbon Steel Class 150 (C2)	Carbon Steel Class 300 (C3)	Stainless Steel Class 150 (S1)	Stainless Steel Class 300 (S3)
030	3 (80)	•	NA	•	•	•
040	4 (100)	•	NA	•	•	•
060	6 (150)	•	NA	•	•	•
080	8 (200)	•	NA	•	•	•
100	10 (250)	•	NA	•	•	•
120	12 (300)	•	NA	•	•	•
140	14 (350)	•	NA	•	•	•
160	16 (400)	•	NA	•	•	•
180	18 (450)	•	NA	•	•	•
200	20 (500)	•	NA	•	•	•
240	24 (600)	•	NA	•	•	•
300 ⁽¹⁾	30 (750)	•	•	NA	•	NA
360 ⁽¹⁾	36 (900)	•	NA	NA	•	NA

(1) AWWA C207 Table 2 Class D Flat Face Flange for option C1 Only

ROSEMOUNT 8711 ORDERING INFORMATION

Model	Product Description
8711	Magnetic Flowmeter Wafer Flowtube Sensor
Code	Lining Material
A	PFA ⁽¹⁾
T	ETFE ⁽²⁾
S	PTFE ⁽³⁾
Code	Electrode Material
S	316L Stainless Steel
H	Nickel Alloy 276 (UNS N10276)
T	Tantalum
P	80% Platinum - 20% Iridium
N	Titanium
Code	Electrode Type
A	2 Electrodes - Standard
B	2 Electrodes - Bullet Nose
E	3rd Grounding Electrode - Standard
Code	Line Size
15F	0.15 in. (4 mm)
30F	0.3 in. (8 mm)
005	½ in. (15 mm)
010	1in. (25 mm)
015	1½ in. (40mm)
020	2 in. (50mm)
030	3 in. (80 mm)
040	4 in. (100 mm)
060	6 in. (150 mm)
080	8 in. (200 mm)
Code	Transmitter Mounting Configuration
R	Remote
U	Integral, mounted to Rosemount 8732E/8742C Transmitter
Continued on Next Page	

Rosemount 8700 Series

Code	Mounting Kit
	Expanded Kit: Includes two alignment rings (where applicable), threaded SST studs, and nuts
1	ASME B16.5 (ANSI) Class 150
2	EN 1092-1 (DIN) PN 10/16 ⁽⁴⁾
3	ASME B16.5 (ANSI) Class 300
4	EN 1092-1 (DIN) PN 25/40 ⁽⁵⁾
	Standard Kit: Includes two alignment rings (where applicable)
5	ASME B16.5 (ANSI) Class 150
6	EN 1092-1 (DIN) PN 10/16 ⁽⁴⁾
7	ASME B16.5 (ANSI) Class 300
8	EN 1092-1 (DIN) PN 25/40 ⁽⁵⁾
Code	Hazardous Area Approval
NA	No Hazardous Area Approval Required; CE Marking
	FM & CSA
N0	FM Class 1 Div 2 for Non-Flammable fluids; CSA Class 1 Div 2
N5	FM Class 1 Div 2 for Flammable fluids
E5	FM Class 1 Div 1, Explosion Proof
	ATEX
E1	ATEX Ex e ia IIC T3... T6, Increased Safety Approval (with I.S. electrodes)
KD	ATEX Ex e ia IIB T3... T6, Increased Safety Approval (with I.S. electrodes)
N1	ATEX Ex nA [L] IIC Type n Approval
ND	ATEX Dust Approval
Code	Options
	Certifications
PD	Pressure Equipment Directive Certification (PED, per 97/23/EC)
DW	NSF Drinking Water Certification ⁽⁶⁾
	Optional Grounding Rings
G1	(2) 316L SST Ground Rings
G2	(2) Nickel Alloy 276 (UNS N10276) Ground Rings
G3	(2) Titanium Ground Rings
G4	(2) Tantalum Ground Rings
	Other Options
D1	High Accuracy Calibration (0.15% of rate for matched tube and transmitter) ⁽⁷⁾
DT	Heavy Duty Tagging
Q4	Calibration Certificate per ISO 10474 3.1B
Q8	Material Traceability 3.1B
Q9	Material Traceability Electrode only 3.1B
Q66	Welding Procedure Qualification Record Documentation ⁽⁸⁾
Q67	Welding Performance Qualification Record Documentation ⁽⁸⁾
Q70	Weld Examination Inspection Certificate, ISO 10474 3.1B ⁽⁸⁾
Typical Model Number: 8711 TSA 020 R 5 N0	

(1) Available with 0.15 and 0.30 in. (4 and 8 mm) line sizes only

(2) Not available with 0.15 and 0.30 in. (4 and 8 mm) line sizes

(3) Not available with 0.15 and 0.30 in. (4 and 8 mm) line sizes

(4) 8 in. (200 mm) has a PN 10 mounting kit only

(5) 8 in. (200 mm) has a PN 25 mounting kit only

(6) Only available with PTFE Liner Material with 316L SST Electrode Material

(7) D1 Option Code must be ordered with flowtube sensor and transmitter

(8) 6 and 8 in. (150 and 200 mm) line sizes only

ROSEMOUNT 8721 ORDERING INFORMATION

Model	Product Description
8721	Sanitary Magnetic Flowmeter
Code	Lining Material
A	PFA
Code	Electrode Material
S	316L SST (standard)
H	Nickel Alloy 276 (UNS N10276)
P	80% Platinum-20% Iridium
Code	Electrode Construction
A	Standard measurement electrodes
Code	Line Sizes
005	15 mm (1/2 in.)
010	25 mm (1 in.)
015	40 mm (1 1/2 in.)
020	50 mm (2.0 in.)
025	65 mm (2 1/2 in.)
030	80 mm (3.0 in.)
040	100 mm (4.0 in.)
Code	Transmitter Mounting Configuration
R	Remote, for use with 8712, or remote version of 8732/8742 transmitter
U	Integral, mounted to 8732/8742 transmitter
X	Flowtube Sensor only (does not include terminal junction box)
Code	Process Connection Type
A	Tri-Clamp ⁽¹⁾
B	IDF Sanitary screw type ⁽²⁾
C	ANSI Weld Nipple ⁽²⁾
D	DIN 11851 (Imperial)
E	DIN 11851 (Metric)
F	DIN 11864-1 form A
G	DIN 11864-2 form A
H	SMS Connection
J	Cherry-Burrell I-Line
K	DIN 11850 Weld Nipple
Code	Process Gasket Material
1	Silicone gasket seal
2	EPDM
4	Viton
8	EPDM Compression - limiting ⁽³⁾
9	Viton Compression - limiting ⁽³⁾
X	No gasket (User supplied; only applicable with Process Connection B)

Continued On Next Page

Rosemount 8700 Series

Code		Product Certifications
NA		CE Marking; 3A; EHEDG Type EL ⁽³⁾ ; no hazardous location approvals
N0		Factory Mutual (FM) Ordinary Location; CSA; CE Marking; 3-A; EHEDG Type EL ⁽³⁾
Code		Options
AH		Electropolished process connection surface finish < 15µinch Ra (0.38µm Ra)
D1		High Accuracy Calibration [0.25% of rate from 3-30 ft/s (0.9-10 m/s)] matched flowtube sensor and transmitter system
D3		High Velocity Calibration Verification. Calibration verified at 1, 3, 10 and 20 ft/sec (0.3, 1, 3, and 6 m/s)
HD		DanFoss Lay Length
HP		Process Data PD340 (Alfa-Laval PD340) 250mm lay length and Tri-Clamp process connections
J1		CM20 Conduit Adapter (Applies to Transmitter Mount Option "R" only)
J2		PG13.5 Conduit Adapter (Applies to Transmitter Mount Option "R" only)
Q4		Inspection Certification for Calibration Data
Q8		Material Traceability Certificate per ISO 10474 3.1B (product contact surfaces)
SJ		304 Stainless Steel terminal junction box (Remote configuration only)
Typical Model Number: 8721 A S A 020 U A 1 N0		

(1) Tri-Clamp specification per BPE-2002

(2) IDF Specification per BS4825 Part 4

(3) EHEDG Document 8 requires mechanical compression limiting, provided by Compression - limiting gaskets for line sizes 1- 4 in. only.

ROSEMOUNT 8714D ORDERING INFORMATION

Model	Description
8714DQ4	Reference Calibration Standard

Rosemount 8700 Series

Tagging

The flowtube sensor and transmitter will be tagged, at no charge, in accordance with customer requirements.

Transmitter tag character height is 0.125 in. (3.18 mm).

Flowtube Sensor tag: 40 character maximum.

Transmitter tag: see Configuration Data Sheet for character maximum.

Ordering Procedure

To order, select the desired flowtube sensor and/or transmitter by specifying model codes from the ordering table.

For remote transmitter applications, note the cable specification requirements.

Flowtube Sensors and transmitters must be selected from Product Data Sheet 00813-0100-4727.

Standard Configuration

Unless the Configuration Data Sheet is completed, the transmitter will be shipped as follows:

Engineering Units:	ft/sec
4 mA (1 V DC):	0
20 mA (5 V DC):	30
Tube Size:	3-in.
Empty Pipe:	Off
Flowtube Sensor Calibration Number:	1000005010000000

The Rosemount 8732E and the 8742C Transmitter are factory-calibrated with the attached flowtube sensor size and appropriate calibration number.

Cable Requirements for Remote Transmitters

Description	Length	P/N
Signal Cable (20 AWG) Belden 8762, Alpha 2411 equivalent	ft m	08712-0061-0001 08712-0061-0003
Coil Drive Cable (14 AWG) Belden 8720, Alpha 2442 equivalent	ft m	08712-0060-0001 08712-0060-0003
Combination Signal and Coil Drive Cable (18 AWG) ⁽¹⁾	ft m	08712-0752-0001 08712-0752-0003

(1) Combination signal and coil drive cable is not recommended for high-signal magmeter system. For remote mount installations, combination signal and coil drive cable should be limited to less than 330 ft (100 m).

Remote transmitter installations require equal lengths of signal and coil drive cables. Integrally mounted transmitters are factory wired and do not require interconnecting cables.

Lengths from 5 to 1,000 feet (1.5 to 300 meters) may be specified, and will be shipped with the flowtube sensor. Cable longer than 100 feet (30 meters) is not recommended for high-signal systems.

Custom Configuration (Option Code C1)

If Option Code C1 is ordered, the Configuration Data Sheet (CDS) must be submitted at the time of order.

Continued from Previous Page

Hardware Jumpers: A) Write Protect, B) Analog Loop Power, C) Pulse Output: Internal or External, D) Alarm Option. Local Display Language: English, Spanish, French, German, Portuguese. Flowtube Sensor Size = .15 - 60" * 3". Flowtube Sensor Calibration No.: 16 Digits from flowtube sensor * 10000501000000

SPECIAL UNITS – OUTPUT INFORMATION EXAMPLE
(If applicable, complete the information on the front as shown in the examples below).

Example 1: User wants Barrels per day (1 Barrel = 31 gallons). Example 2: User wants Kgs per minute (Density = 1.05 Kg/Liter with 1 Kg = 0.9524 liters). Includes conversion details for Vol Unit, Base Units, Conversion No., Time Base, and Rate Units.

Basic Diagnostics Information

Empty Pipe: Enable/Disable, Trigger Level, Empty Pipe Counts. Electronics Temperature: Enable/Disable.

Advanced Diagnostics Information (Requires DA1 Option)

High Process Noise: Enable/Disable. Grounding/Wiring Faults: Enable/Disable. NOTE: If DA1 is selected in the model code, Empty Pipe and Electronics Temp Diagnostics will also be enabled.

8714i Meter Verification Diagnostic (Requires DA2 Option)

Test Criteria: Empty Pipe (5%), Flowing Full (3%), Full, No Flow (2%). NOTE: The Test Criteria value sets the pass fail value for the meter calibration verification check. This value must be an integer value between 1 and 10%.

Digital Input / Digital Output Information (Requires AX Option)

Digital Input: Enable/Disable, Positive Zero Return (PZR), Totalizer Reset, Transmitter Reset. Digital Output: Enable/Disable, Empty Pipe, Zero Flow, Reverse Flow, Transmitter Fault.

Continued On Next Page

AUXILIARY OUTPUT INFORMATION (Not Required for Typical Start-up)

Pulse Scaling: <input type="checkbox"/> ★.03 ft <input type="checkbox"/> 1 Pulse = _____ units Low Flow Cutoff: _____ ★ 0.04 ft/sec Pulse Width: _____ ★ 0.5 m/s	Operation Mode: <input type="checkbox"/> ★ Normal <input type="checkbox"/> Filter (Operating Mode for 8712H is not available.) Coil Pulse Mode: <input type="checkbox"/> ★ 5 Hz (Default) <input type="checkbox"/> 37.5 Hz Signal Processing: <input type="checkbox"/> ★ Off <input type="checkbox"/> On _____ ★ 90 No. Samples _____ ★ 2 Max.% Limit % _____ ★ 2 Time Limit Sec
---	---

FLOWTUBE SENSOR INFORMATION (Data Only – Does Not Affect Transmitter Output)

SST Flowtube Sensor Tag No.: _____

Flowtube Sensor Serial No: |_|_|_|_|_|_|_|_|_|_| (7 characters maximum)

Enter either the Rosemount flowtube sensor model number or select one option from each of the following groups of options:

Flowtube Sensor Model No. _____

Or:

Electrode Material:

- | | |
|---|---|
| <input type="checkbox"/> ★316 SST | <input type="checkbox"/> Tantalum |
| <input type="checkbox"/> Titanium | <input type="checkbox"/> Platinum-Iridium |
| <input type="checkbox"/> Alloy-20 | <input type="checkbox"/> Special |
| <input type="checkbox"/> Nickel Alloy 276 (UNS N10276) [®] | |

Electrode Type:

- | | |
|--|---|
| <input type="checkbox"/> ★ Standard | <input type="checkbox"/> Standard, plus Grounding |
| <input type="checkbox"/> Bullet | <input type="checkbox"/> Special |

Flange Material:

- | | |
|---|----------------------------------|
| <input type="checkbox"/> ★Carbon Steel | <input type="checkbox"/> 304 SST |
| | <input type="checkbox"/> Special |

Liner Material:

- | | |
|--|-----------------------------------|
| <input type="checkbox"/> ★ PTFE | <input type="checkbox"/> Neoprene |
| <input type="checkbox"/> ETFE | <input type="checkbox"/> Special |
| <input type="checkbox"/> Polyurethane | |

★ 4–20 mA and scaled pulse with simultaneous digital signal based on HART[®] protocol

Burst mode of HART digital process variable

Burst mode output options:

- Primary variable in engineering units.
- Primary variable in percent of range.
- All dynamic variables in engineering units.
- All dynamic variables in engineering units and the primary variable mA value.

Multidrop Communications⁽³⁾

Choose transmitter address (1-15)⁽⁴⁾: _____

(1) Mass units require a process density. Standard/Normal units require a density ratio.

(2) Required for mass or standard/normal flow units.

(3) This option fixes the transmitter's analog output at 4 mA.

(4) Default transmitter address is 1 if multidrop communication is selected.

Product Data Sheet

00813-0100-4727, Rev RA
December 2007

Rosemount 8700 Series

Hardware Switches

- A) Write Protect ★ **Off** On
B) Analog Loop Power ★ **Internal** External
C) Alarm Option ★ **High** Low
Flowtube Sensor Size = _____ .15 – 60" ★ **3"**

Flowtube Sensor Calibration No.: |_|_|_|_|_|_|_|_|_|_|_|_|_|_|_|_|_| 16 Digits from flowtube sensor ★ **1000005010000000**

SPECIAL UNITS – OUTPUT INFORMATION EXAMPLE (If applicable, complete the information on the front as shown in the examples below).

Example 1:

User wants Barrels per day
(1 Barrel = 31 gallons):

- ①Vol Unit = BARL
- ②Base Units = Gallons
- ③Conversion No. = 31.0
- ④Time Base = Day
- ⑤Rate Units = B/DY

Example 2:

User wants Kgs per minute
(Density = 1.05 Kg/Liter with 1 Kg = 0.9524 liters):

- ①Vol Unit = Kg
- ②Base Units = Liters
- ③Conversion No. = 0.9524
- ④Time Base = Minute
- ⑤Rate Units = Kg/m

Basic Diagnostics Information

Empty Pipe

- Enable Trigger Level _____ 100★
 Disable★ Empty Pipe Counts _____ 5★

Electronics Temperature

- Enable
 Disable★

Advanced Diagnostics Information (Requires DA1 Option)

- High Process Noise Enable★ Disable
Grounding/Wiring Faults Enable★ Disable

NOTE

If DA1 is selected in the model code, Empty Pipe and Electronics Temp Diagnostics will also be enabled.

AUXILIARY OUTPUT INFORMATION (Not Required for Typical Start-up)

Pulse Scaling:

- ★ **.03 ft**
 1 Pulse = _____ units

Auxiliary Output Control:

- ★ **Zero Flow**

- Reverse Flow

Low Flow Cutoff:

_____ ★ **0.04 ft/sec**

Pulse Width:

_____ ★ **0.5 m/s**

Operation Mode:

- ★ **Normal**
 Filter (Operating Mode for 8712H is not available.)

Coil Pulse Mode:

- ★ **5 Hz**
(Default)

- 37.5 Hz

Signal Processing:

- ★ **Off**
 On
_____ ★ **90** No. Samples
_____ ★ **2** Max.% Limit %
_____ ★ **2** Time Limit Sec

Continued On Next Page

Rosemount 8700 Series

FLOWTUBE SENSOR INFORMATION (Data Only – Does Not Affect Transmitter Output)

SST Flowtube Sensor Tag No.: _____

Flowtube Sensor Serial No: |_|_|_|_|_|_|_|_|_|_| (7 characters maximum)

Enter either the Rosemount flowtube sensor model number or select one option from each of the following groups of options:

Flowtube Sensor Model No. _____

Or:

Electrode Material:

- ★ **316 SST**
- Titanium Tantalum
- Alloy-20 Platinum-Iridium
- Nickel Alloy 276 (UNS N10276)[®] Special

Electrode Type:

- ★ **Standard**
- Bullet Standard, plus Grounding
- Special

Flange Material:

- ★ **Carbon Steel**
- 304 SST
- Special

Liner Material:

- ★ **PTFE**
- ETFE Neoprene
- Polyurethane Special

- ★ **4–20 mA, scaled pulse, and auxiliary output with simultaneous digital signal based on HART[®] protocol**
- Burst mode of HART digital process variable

Burst mode output options:

- Primary variable in engineering units.
- Primary variable in percent of range.
- All dynamic variables in engineering units.
- All dynamic variables in engineering units and the primary variable mA value.

- Multidrop Communications⁽³⁾

Choose transmitter address (1-15)⁽⁴⁾: _____

(1) Mass units require a process density. Standard/Normal units require a density ratio.

(2) Required for mass or standard/normal flow units.

(3) This option fixes the transmitter's analog output at 4 mA.

(4) Default transmitter address is 1 if multidrop communication is selected.

Rosemount 8700 Series

AUXILIARY OUTPUT INFORMATION (Not Required for Typical Start-up)

Empty Pipe Functionality:

- ★ Off**
 On

Pulse Scaling:

- ★.03 ft**
 1 Pulse = _____ units

Auxiliary Output Control:

- ★ Zero Flow**
 Reverse Flow

Low Flow Cutoff:

_____ **★ 0.1 ft/sec**

Pulse Width:

_____ **★ 0.5 m/s**

Multidrop Communications⁽¹⁾

Choose transmitter address (1-15)⁽²⁾: _____

Operation Mode:

- ★ Normal**
 Filter

Signal Processing:

- ★ Off**
 On
_____ **★ 90** No. Samples
_____ **★ 2** Max.% Limit %
_____ **★ 2** Time Limit Sec

FLOWTUBE SENSOR INFORMATION (Data Only – Does Not Affect Transmitter Output)

SST Flowtube Sensor Tag No.: _____

Flowtube Sensor Serial No: |_|_|_|_|_|_|_|_|_| (7 characters maximum)

Enter either the Rosemount flowtube sensor model number or select one option from each of the following groups of options:

Flowtube Sensor Model No. _____

Or:

Electrode Material:

- ★316 SST**
 Titanium
 Alloy-20
 Nickel Alloy 276 (UNS N10276)[®]
 Tantalum
 Platinum-Iridium
 Special

Electrode Type:

- ★ Standard**
 Bullet
 Standard, plus Grounding
 Special

Flange Material:

- ★Carbon Steel**
 304 SST
 Special

Liner Material:

- ★ PTFE**
 ETFE
 Polyurethane
 Neoprene
 Special

★ 4–20 mA, scaled pulse, and auxiliary output with simultaneous digital signal based on HART[®] protocol

4–20 mA and auxiliary output with simultaneous digital signal based on HART protocol (Rosemount 8732E only)

Burst mode of HART digital process variable

Burst mode output options:

- Primary variable in engineering units.
 Primary variable in percent of range.
 All dynamic variables in engineering units.
 All dynamic variables in engineering units and the primary variable mA value.

(1) This option fixes the transmitter's analog output at 4 mA.

(2) Default transmitter address is 1 if multidrop communication is selected.

Rosemount 8700 Series

Product Data Sheet
00813-0100-4727, Rev RA
December 2007

*Rosemount and the Rosemount logotype are registered trademarks of Rosemount Inc.
The Emerson logo is a trade mark and service mark of Emerson Electric Co.
PlantWeb is a mark of one of the Emerson Process Management companies.
All other marks are the property of their respective owners.
PlantWeb and DeltaV are trademarks of the Fisher-Rosemount Group of Companies.
HART is a registered trademark of the HART Communication Foundations.
Foundation is a trademark of the Fieldbus Foundation.
Hastelloy and Hastelloy C are registered trademarks of Haynes International.
Teflon and Tefzel are registered trademarks of E.I. du Pont de Nemours & Co.
Tri-Clamp is a registered trademark of Tri-Clover, Inc. of the Alfa-Laval Group.
Foxboro and I/A Series are registered trademarks of the Foxboro Company.
ABB Fischer & Porter is a registered trademark of ABB Company.
Eurofast and Minifast are registered trademarks of Turck Inc.
Cover Photo: 8700_01ba.tif*

Standard Terms and Conditions of Sale can be found at www.rosemount.com/terms_of_sale

Emerson Process Management

Rosemount Inc.

8200 Market Boulevard
Chanhassen, MN 55317 USA
T (U.S.) 1-800-999-9307
T (International) (952) 906-8888
F (952) 949-7001

www.rosemount.com



Emerson Process Management Flow

Neonstraat 1
6718 WX Ede
The Netherlands
T +31 (0)318 495555
F +31(0) 318 495556

Emerson Process Management

Singapore Pte Ltd.
1 Pandan Crescent
Singapore 128461
Tel (65) 6777-8211
Fax (65) 6777-0947
Enquiries@AP.EmersonProcess.com



EMERSON
Process Management