

High Performance Guided Wave Radar

The Rosemount 5300 Series is our premium 2-wire guided wave radar for challenging level and interface measurements on liquids, slurries and solids. It delivers everything you would expect from a best-in-class process radar – superior reliability, state-of-the-art safety features, effortless handling, and unlimited connectivity.

- *Long measuring ranges and reliable measurements on low-reflective media due to Direct Switch Technology and Probe End Projection function.*
- *± 3 mm accuracy with advanced timing method.*
- *Application flexibility with full range of probe styles.*
- *Less instruments and process penetration with a Multivariable™ transmitter.*
- *Powerful and easy-to-use configuration tools.*
- *Reduced cost and increased safety thanks to a robust modular design.*
- *Increased plant availability with Advanced PlantWeb® functionality.*
- *Improved EMC performance with a smart galvanic interface.*
- *Virtually unaffected by application conditions.*



Content

Taking Guided Wave Radar Benefits to the Next Level	Level-2
Optimized to Suit More Applications.	Level-3
System Integration	Level-4
Select Guided Wave Radar Transmitter.	Level-6
Measuring Range	Level-11
Interface	Level-12
Replacing a Displacer in an Existing Displacer Cage.	Level-13
Solids	Level-14
Mechanical Considerations	Level-15
Specifications	Level-17
Product Certifications	Level-21
Dimensional Drawings	Level-23
Ordering Information.	Level-32

Taking Guided Wave Radar Benefits to the Next Level

MEASUREMENT PRINCIPLE

Rosemount 5300 Series is based on the Time Domain Reflectometry (TDR) technology.

Low power nano-second microwave pulses are guided down a probe submerged in the process media. When a radar pulse reaches a media with a different dielectric constant, part of the energy is reflected to the transmitter. The time difference between the transmitted and the reflected pulse is converted into a distance from which the total level or interface level is calculated.

The intensity of the reflection depends on the dielectric constant of the product. The higher the dielectric constant value is, the stronger the reflection will be.

TECHNOLOGY BENEFITS

- No moving parts and no calibration means minimized maintenance.
- Top-down, direct measurement, unaffected by changing process conditions (such as density, conductivity, temperature and pressure).
- Virtually unaffected by dust, vapor and turbulence.
- Even suitable for small tanks, difficult tank geometry, and interfering obstacles.
- Easy upgrade (existing and small openings can be used).

SPECIAL 5300 FEATURES

Direct Switch Technology (DST)

The Rosemount 5300 delivers cutting edge performance with DST, which is a rapid switch for signal transmission between the transmitter and the receiver. It minimizes signal losses, which results in a two to five times stronger received signal compared to other guided wave radar transmitters. It results in a better signal-to-noise ratio and an increased ability to handle disturbing factors.

It also enables long measuring ranges (up to 164 ft (50 m)) and measurements on low reflective media (dielectrics from 1.4), even with a single lead probe.

Probe End Projection (PEP)

PEP is a function to handle long measuring ranges on media with low dielectrics. If the signal is not reflected at the surface, the 5300 uses the probe end as a reference to calculate the actual level.

Smart Galvanic Interface

Innovative ground plane configuration between electronics, microwave and housing, results in a more stable microwave performance and minimizes unwanted disturbances. This improves the EMC performance and provides a more robust measurement.

Advanced Timing

The 5300 uses a patented timing method that gives ± 3 mm reference accuracy.

Robust Modular Design

The 5300 has a dual compartment head to separate electronics from cable connection. It has easy-to-access and robust cable terminals and an optional easy-to-read display. The head can be rotated 360°, and is removable while the tank is in service. There is no matching between head and probes. All of this adds up to reduced cost and increased safety. See "Transmitter Housing" on page 6.

Full Range of Probe Styles for Application Flexibility

Probes are available in different styles and materials, also with options to handle extreme pressure and temperature. See "Probes" on page 8.

Powerful Configuration Tools

Rosemount Radar Master™ with its user-friendly interface is the ultimate setup and troubleshooting software. See "Configuration" on page 5.

Advanced PlantWeb™ functionality

The 5300 powers the PlantWeb architecture by delivering the best Multivariable™ transmitter (both level and interface from the same 2-wire unit), the best installation practices, and the best field intelligence with advanced diagnostics for HART® and FOUNDATION™ fieldbus. This enables proactive maintenance for increased process availability. See "Configuration" on page 5.

Product Data Sheet

00813-0100-4530, Rev AA

Catalog 2008 - 2009

Rosemount 5300 Series

Optimized to Suit More Applications

The Rosemount 5300 offers reliable level measurement benefits for a wider range of applications than ever before. It is suitable for all types of processing industries, oil & gas production, refining, petrochemical, chemical, power, water and waste treatment.

Its probe guided radar signal, combined with innovative engineering, makes the 5300 virtually unaffected by process conditions and it has almost no installation restrictions.

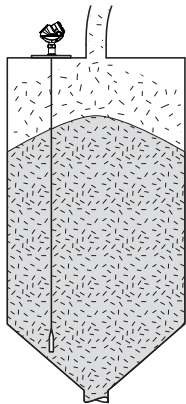

Solids performance

Rosemount 5303 with a flexible single lead probe measures in solids with dielectric constants as low as 1.4.

Probes for high physical weight loads are available.

The 5300 measures on powders, granules, plastics such as PVC, cement, fly ash, corn etc.

The measuring range is up to 164 ft (50 m).

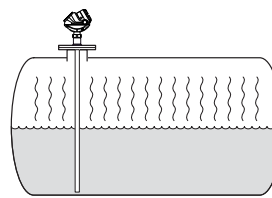

Improved performance in liquefied gases

Rosemount 5300 is perfect for liquid gas applications, since the transmitter head can be serviced without opening the tank.

Long measuring ranges enable operation in larger LPG, NGL and ammonia tanks.

The 5300 transmitter also manages to measure on turbulent products.

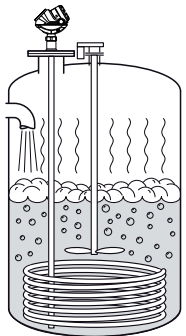

Measure in vessels with turbulence, vapor and mechanical structures

The Rosemount 5300 delivers uninterrupted level data where others fail. Thanks to the patented Direct Switch Technology, the received signal is two to five times stronger compared to other guided wave radars. The result is a superior ability to handle disturbing objects, probe coating, foam, vapor and turbulence.

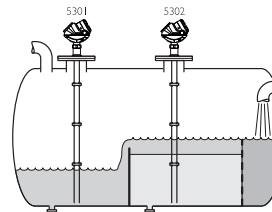

Combine level and interface measurement

One 5300 transmitter measures both the upper surface and the lower product interface in tanks with two products. Examples are separators, settling tanks etc.

Additional tank penetrations can therefore be avoided.

Use Rosemount 5300 with the single lead probe for reliable measurements of interface in crude oil and other liquids causing product build-up.

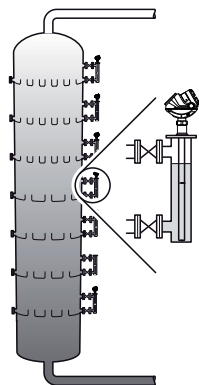

Minimize risk in the most demanding environments

Innovative technology with robust probes for extreme environments enable reliable performance in high temperature and pressure tanks and bridges. Examples are refinery distillation columns, power feed-water tanks etc. The measurement is not affected by density variations, low reflectivity media or the mechanical configuration of the bridge and product inlet.

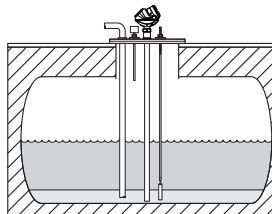

Underground benefits

Probes that are unaffected by high and narrow openings or nearby objects are available. This makes the 5300 a good choice for underground tanks where the installation area normally is limited.

System Integration

INPUTS / OUTPUTS

The 5300 Series transmitter uses the same two wires for both power supply (see page Level-20) and communication.

Measurement data is transmitted as an analog 4-20 mA signal with a superimposed digital HART® signal or FOUNDATION™ fieldbus signal.

The HART® signal can be used in a multidrop mode. By sending the digital HART® signal to the optional HART® Tri-loop, it is possible to have up to three additional 4-20 mA analog signals.

See the Rosemount 333 HART® Tri-loop Product Data Sheet (document number 00813-0100-4754) for additional information.

HART®

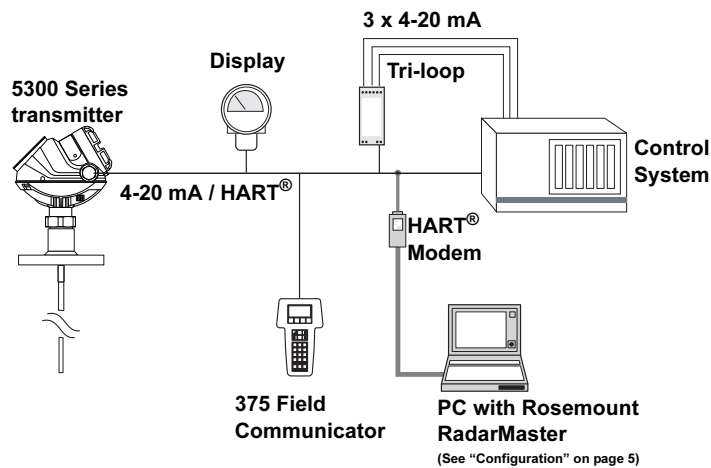

FOUNDATION™ fieldbus

Host / DCS system (e.g. DeltaV®)

Maintenance

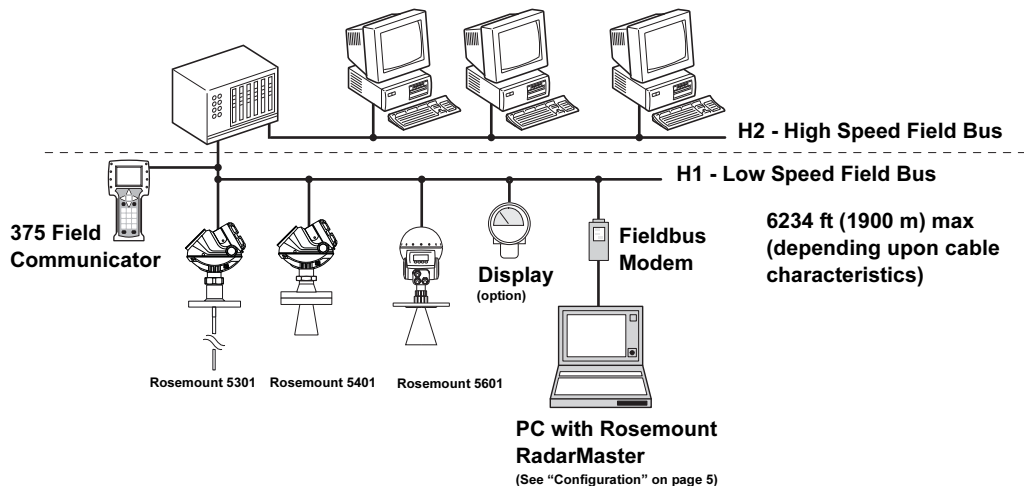

Note:
 Intrinsically safe installations may allow fewer devices per I.S. barrier due to current limitations.

Product Data Sheet

00813-0100-4530, Rev AA
Catalog 2008 - 2009

Rosemount 5300 Series

The transmitter is available with Intrinsically Safe⁽¹⁾ / Non-Incendive or Explosionproof / Flameproof approvals. A safety isolator such as a zener barrier must be used for intrinsic safety. Refer to "Product Certifications" on page 21 and "Ordering Information" on page 32.



The optional HART[®] Tri-loop, HART-to-Analog signal converter.

DISPLAY

Data can be read from the optional integral display or remotely by using the Rosemount 751 Field Signal Indicator for 4-20 mA / HART[®] (see Product Data Sheet, document number 00813-0100-4378), or the Rosemount 752 Remote Indicator for FOUNDATION[™] fieldbus (see Product Data Sheet, document number 00813-0100-4377).



The integral display is easily configured with Rosemount RadarMaster or the Rosemount 375 Field Communicator. The user can choose which variable to display or if toggling between different variables should be applied.

MEASUREMENT PARAMETERS

From one Rosemount 5300 Series radar transmitter it is possible to receive multiple process variables. See information on parameters and transmitter models in the following table. Rosemount 5301, 5302, and 5303 are described in "Transmitter Housing" on page 6.

	5301	5302	5303
Level	X	X	X
Distance to Level	X	X	X
Interface Level	(X)*	X	
Interface Distance	(X)*	X	
Upper Layer Thickness		X	
Total Volume	X	X	X
Upper Volume	(X)*	X	
Lower Volume	(X)*	X	

* Interface measurement only for fully submerged probe, see page Level-12.

CONFIGURATION



Basic configuration can easily be done either with Rosemount RadarMaster, a Rosemount 375 Field Communicator, the AMS[™] Suite, DeltaV[®] or any other DD (Device Description) compatible host system. For advanced configuration features and extensive diagnostics, RadarMaster, or an alternative host that supports enhanced EDDL (such as the AMS Device Manager) is required.

RadarMaster is a user-friendly, Windows based software package that provides easy configuration and service for both FOUNDATION[™] fieldbus and HART[®]. A wizard guides the user to enter the required parameters for a basic configuration. "Measure & Learn" functionality is accessed through RadarMaster. It enables automatic suggestion of level threshold values, thereby making tough applications easy to configure. RadarMaster also includes an echo curve with movie feature, off-line configuration, logging and extensive on-line help.

The Enhanced EDDL capabilities of the 5300 Series also make it possible to view the echo curve from a field communicator or AMS, and to initiate the Measure-and-Learn functionality in the transmitter.

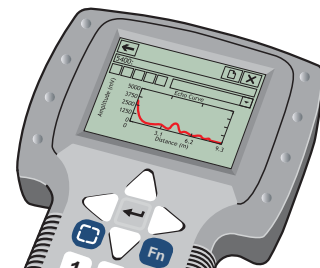

It is possible to view the echo curve from a Rosemount 375 Field Communicator.

(1) Fisco Intrinsic safety is available for Foundation[™] fieldbus. See "Ordering Information" on page 32 for more information on available approvals.

For 4-20 mA or HART®, a HART® modem is required for communication between the transmitter and RadarMaster (part number 03300-7004-0001 for RS232 and 03300-7004-0002 for USB interface).

For FOUNDATION™ fieldbus devices, RadarMaster is connected to the fieldbus segment via the fieldbus modem (part number 03095-5108-0001 for PCMCIA). For more information, see the 5300 Reference Manual (document number 00809-0100-4530) or consult factory.

By filling in the Configuration Data Sheet (CDS), it is possible to order a pre-configured transmitter.

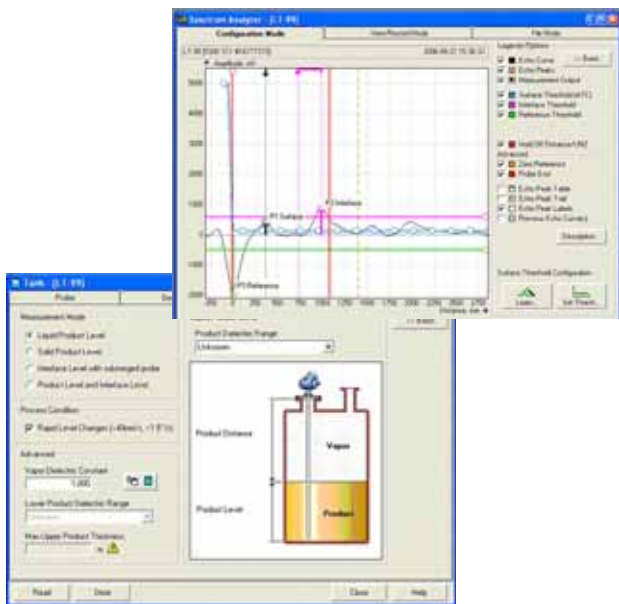

Rosemount RadarMaster enables easy configuration and service with its user-friendly interface, including wizards, echo curve with movie feature, offline/online configuration, extensive online help, logging capabilities and much more.

ADVANCED PLANTWEB® FUNCTIONALITY



Rosemount 5300 transmitters support PlantWeb® Alerts. The Rosemount 5300 Series transmitter powers PlantWeb® through multivariable and innovative measurement technologies in combination with advanced diagnostics that provides higher reliability, easier configuration, reduced process downtime, lower installation and operating costs for a better bottom line.

Select Guided Wave Radar Transmitter

A Rosemount 5300 Series transmitter consists of a transmitter housing, a tank connection and a probe. Probe and tank connection are the only parts in contact with the tank atmosphere.

The transmitter can be equipped with different probes to fulfill various application requirements. The 5300 Series is based on a modular design, which means there is no matching between probe styles and transmitter housing. Any probe can be used with any transmitter housing, giving full flexibility.



TRANSMITTER HOUSING ①

The transmitter is available in three models:

- Rosemount 5301, for liquid level or submerged interface measurements.
- Rosemount 5302, for liquid level and interface measurements.
- Rosemount 5303, for solid level measurements.

It can be ordered with Intrinsically Safe or Explosion Proof / Flame Proof certification (see "Product Certifications" on page 21).

The housing is available in polyurethane covered Aluminium. The dual compartment transmitter housing can be removed without opening the tank. It has electronics and cabling separated. The housing has two entries for conduit/cable connections.

The 5300 Series is available with 1/2 in. NPT cable entry as standard. M20, eurofast or minifast are adapter options. See "Ordering Information" on page 32.

Product Data Sheet

00813-0100-4530, Rev AA
 Catalog 2008 - 2009

Rosemount 5300 Series

TANK CONNECTION ⁽²⁾

The tank connection consists of a tank seal, a flange⁽¹⁾ or NPT or BSP/G threads⁽²⁾. See "Ordering Information" on page 32).

Flange mating face dimensions follow ANSI B 16.5, JIS B2220, and EN 1092-1 (DIN 2527) standards for blind flanges. Fisher and Masoneilan flanges are also available (see "Special Flanges and Flushing Connection Rings" on page 31).

Flanged Hastelloy®, Monel® and PTFE covered probes have a tank connection design with a protective plate made of the same material as the probe, to prevent the 316L / EN 1.4404 SST flange from being exposed to the tank atmosphere.

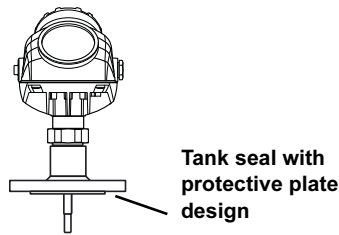

Temperature and Pressure Ratings

The following diagrams give process temperature (max product temperature at the lower part of the flange) and pressure ratings for tank connections:

- Standard (Std)
- High Pressure (HP)
- High Temperature and High Pressure (HTHP)

For standard tank connection, the final rating depends on flange and O-ring selection.

Max. Rating, Standard Connections

Pressure
psig (bar)

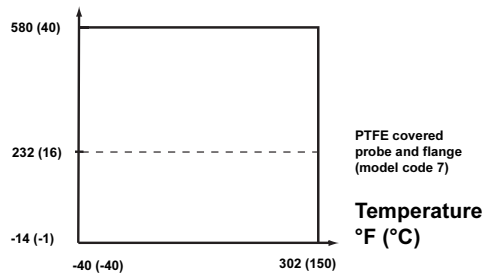

Max. Rating, HTHP Connections

Pressure
psig (bar)

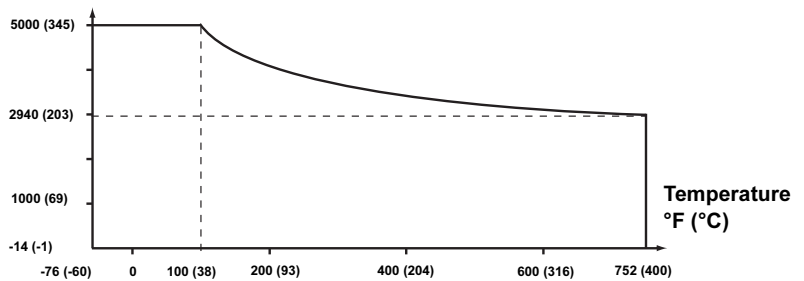

The following table gives the temperature ranges for standard tank seals with different O-ring materials.

Tank seal with different O-ring material	Min. Temperature °F (°C) in air	Max. Temperature °F (°C) in air
Viton®	5 (-15)	302 (150)
Ethylene Propylene (EPDM)	-40 (-40)	266 (130)
Kalrez® 6375	14 (-10)	302 (150)
Buna-N	-31 (-35)	230 (110)

The HP and HTHP versions have a ceramic tank seal, and graphite gaskets - no O-rings are used. The final rating depends on flange selection.

The difference between the HP and HTHP versions is spacer material; PFA for HP, and ceramics for HTHP. Ceramic spacers allow for usage in applications with higher temperature. The HP and HTHP versions also manage lower temperatures than the standard version.

Max. Rating, HP Connections

Pressure
psig (bar)

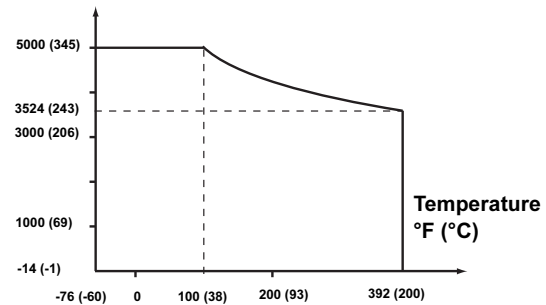

(1) EN (DIN), ANSI, Fisher or Masoneilan. See page 31.

(2) 1 or 1.5 in. depending on probe type

Flange Rating

- **ANSI:**
According to ANSI B16.5 Table 2-2.3.
Standard: Max. 302 °F/580 psig
(150 °C/40 Bar).
HP/HTHP: Up to Class 2500.
- **EN:**
According to EN 1092-1 Table 18, material group 13E0.
Standard: Max. 302 °F/580 psig
(150 °C/40 Bar).
HP/HTHP: Up to PN 320.
- **Fisher & Masoneilan:**
According to ANSI B16.5 Table 2-2.3.
Standard: Max. 302 °F/580 psig
(150 °C/40 Bar).
HP/HTHP: Up to Class 600.
- **JIS:**
According to JIS B2220 Table 2.3
Standard: 10K/20K/150C.
HP: 10K/20K/200C.
HTHP: 10K/20K/400C

Ambient Temperature

The maximum ambient temperature depends on the process temperature according to the graph below. Nozzle insulation for the HTHP version should not exceed 4 in. (10 cm).

Ambient Temperature
°F (°C)

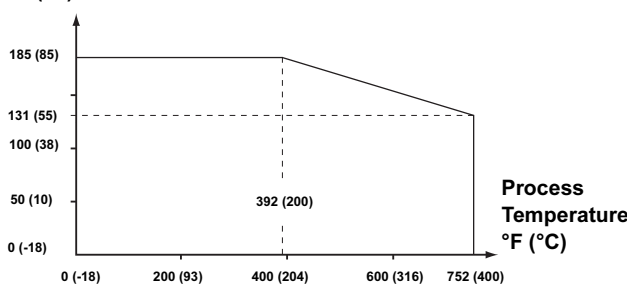

PROBES ③

Several versions of the probes are available: Coaxial (perforated and non-perforated versions), Rigid Twin and Rigid Single Lead, Flexible Twin and Flexible Single Lead. Probes can be ordered in different materials, and there are options for extreme temperatures and pressure.

Total probe length is defined from the upper reference point to the end of the probe (weight included if applicable).

For guidance in probe selection, see page 10.

The table on page 9 shows what probe types that are available for different materials of construction and for the HP & HTHP options.

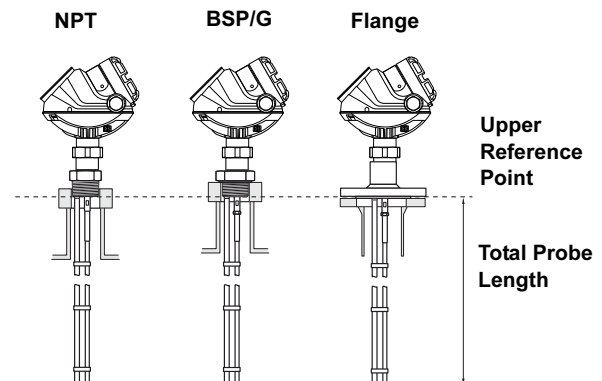

Total Probe Length and Upper Reference Point (right below flange / thread).

Product Data Sheet

00813-0100-4530, Rev AA

Catalog 2008 - 2009

Rosemount 5300 Series

	Coaxial	Rigid Twin Lead	Flexible Twin Lead	Rigid Single Lead	Flex Single Lead
SST Probe	X	X	X	X	X
Hastelloy Probe	X			X	
Monel Probe	X			X	
PTFE Covered Probe				X	X ⁽¹⁾
HTHP Probe (SST)	X			X	X ⁽¹⁾
HP Probe (SST)	X			X	X ⁽¹⁾

(1) For measurements on liquids only. Consult factory if option is needed for solids.

Transition Zones

Transition zones are areas where measurements are non-linear or will have reduced accuracy. See picture and table below.

If measurements are desired at the very top of the tank it is possible to mechanically extend the nozzle and use the coaxial probe. Then the upper transition zone is moved into the extension.

NOTE

The 4-20 mA set points are recommended to be configured between the transition zones, within the measuring range (see picture and diagram above).

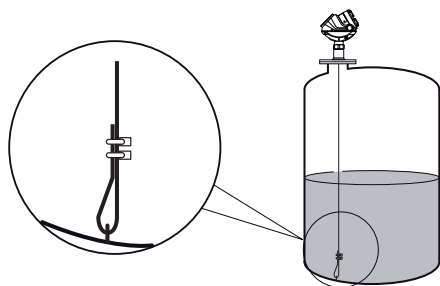
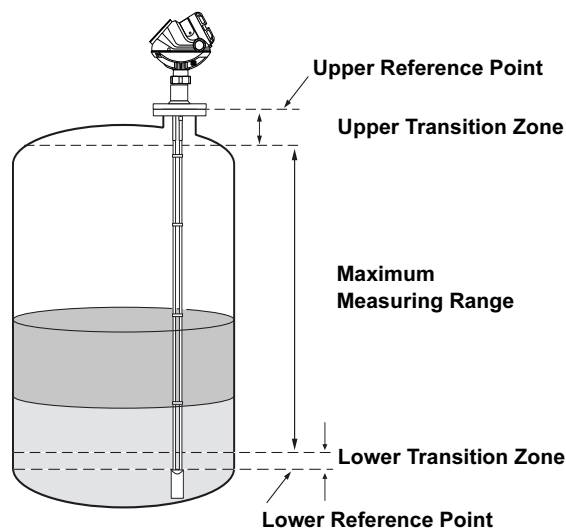

For a flexible single lead probe with chuck, the lower transition zone is measured upwards from the upper clamp.

	Dielectric Constant	Coaxial	Rigid Twin Lead	Flexible Twin Lead	Rigid Single Lead	Flexible Single Lead
Upper⁽¹⁾ Transition Zone	80	4.3 in. (11 cm)	4.3 in. (11 cm)	4.7 in. (12 cm)	4.3 in. (11 cm)	4.3 in. (11 cm)
	2	4.3 in. (11 cm)	5.5 in. (14 cm)	5.5 in. (14 cm)	6.3 in. (16 cm)	7.1 in. (18 cm)
Lower⁽²⁾ Transition Zone	80	0.4 in. (1 cm)	1.2 in. (3 cm)	2 in. ⁽³⁾ (5 cm ⁽³⁾)	2 in. (5 cm)	0 in. ⁽³⁾⁽⁴⁾ (0 cm ⁽³⁾⁽⁴⁾)
	2	2 in. (5 cm)	4 in. (10 cm)	5.5 in. ⁽³⁾ (14 cm ⁽³⁾)	2.8 in. ⁽⁵⁾ (7 cm ⁽⁵⁾)	2 in. ⁽³⁾ (5 cm ⁽³⁾)

(1) The distance from the upper reference point where measurements have reduced accuracy, see picture above.

(2) The distance from the lower reference point where measurements have reduced accuracy, see picture above.



(3) Note that the weight length adds to non-measurable area and is not included in the diagram. See "Dimensional Drawings".

(4) The measuring range for the PTFE covered Flexible Single Lead probe includes the weight when measuring on a high dielectric media.

(5) If using a stainless steel centering disc, the lower transition zone is 8 in. (20 cm). If using a PTFE centering disc, the lower transition zone is not affected.

Rosemount 5300 Series

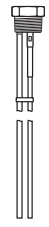
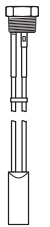
In the table below: G=Good, NR=Not Recommended, AD=Application Dependent (consult factory).

	Coaxial	Rigid Twin Lead	Flexible Twin Lead	Rigid Single Lead	Flexible Single Lead
This table gives guidelines on which probe to select, depending on application.					
Measurements					
Level	G	G	G	G	G
Interface (liquid/liquid)	G	G	G	G	G
Process Medium Characteristics					
Changing density	G	G	G	G	G
Changing dielectric ⁽¹⁾	G	G	G	G	G
Wide pH variations	G	G	G	G	G
Pressure changes	G	G	G	G	G
Temperature changes	G	G	G	G	G
Condensing vapors	G	G	G	G	G
Bubbling / boiling surfaces	G	G	G	G	AD
Foam (mechanical avoidance)	AD	NR	NR	NR	NR
Foam (top of foam measurement)	NR	AD	AD	AD	AD
Foam (foam and liquid measurement)	NR	AD	AD	AD	AD
Clean liquids	G	G	G	G	G
Materials with very low dielectric	G	G	G ⁽²⁾	G	G ⁽²⁾
Coating/sticky liquids	NR	NR	NR	AD	AD
Viscous liquids	NR	AD	AD	AD	G
Crystallizing liquids	NR	NR	NR	AD	AD
Solids, granules, powders	NR	NR	NR	AD	G
Fibrous liquids	NR	NR	NR	G	G
Tank Environment Considerations					
Probe is close (< 12 in. / 30 cm) to tank wall/disturbing objects	G	G	G	AD	AD
Probe might touch tank wall, nozzle or disturbing objects	G	NR	NR	NR	NR
Turbulence	G	G	AD	G	AD
Turbulence conditions causing breaking forces	NR	NR	AD	NR	AD
Tall, narrow nozzles	G	AD	AD	NR	NR
Angled or slanted surface (viscous or solids materials)	NR	AD	AD	G	G
Liquid or vapor spray might touch probe above surface	G	NR	NR	NR	NR
Disturbing EMC environment in tank	G	AD	AD	AD	AD
Cleanability of probe	NR	AD	AD	G	G

(1) For overall level applications, a changing dielectric has no effect on the measurement. For interface measurements, a changing dielectric of the top fluid will degrade the accuracy of the interface measurement.

(2) With limited measuring range, see page Level-11.

Measuring Range

In the table below, measuring range information is given for each probe. Since the measuring range depends on the application and on the different factors described in this chapter, the values are given as a guideline for clean liquids. For more information, consult factory.

Coaxial	Rigid Twin Lead	Flexible Twin Lead	Rigid Single Lead	Flexible Single Lead ⁽¹⁾
Maximum Measuring Range				
19 ft 8 in. (6 m)	9 ft 10 in. (3 m)	164 ft (50 m)	9 ft 10 in. (3 m)	164 ft (50 m)
Minimum Dielectric Constant				
1.2 (Std) 1.4 (HP) 2.0 (HTHP)	1.4	1.4, up to 82 ft (25 m) ⁽¹⁾ 2.0, up to 115 ft (35 m) ⁽¹⁾ 2.5, up to 131 ft (40 m) ⁽¹⁾ 3.5, up to 148 ft (45 m) 6, up to 164 ft (50 m)	1.4 (1.25 if installed in a metallic bypass or stilling well) ⁽¹⁾⁽²⁾	1.4, up to 49 ft (15 m) ⁽¹⁾ 1.8, up to 82 ft (25 m) ⁽¹⁾ 2.0, up to 115 ft (35 m) ⁽¹⁾ 3, up to 138 ft (42 m) 4, up to 151 ft (46 m) 6, up to 164 ft (50 m)

(1) Probe end projection software function will improve the minimum measurable dielectric constant. Consult factory for details.

(2) May be lower depending on installation.

Different parameters affect the echo and therefore the maximum measuring range differs depending on application according to:

- Disturbing objects close to the probe.
- Media with higher dielectric constant gives better reflection and allows a longer measuring range.
- Surface foam and particles in the tank atmosphere are circumstances that might affect measuring performance.
- Heavy coating / contamination on the probe can reduce the measuring range and might cause erroneous level readings. Consider to use a single lead probe or a non-contact radar transmitter.
- Tank material (e.g. concrete or plastic) for measurements with single lead probes (see "Mechanical Considerations" on page Level-16).

Coating

- Single lead probes are preferred when there is a risk for contamination (because coating can result in product bridging across the two leads for twin versions; between the inner lead and outer pipe for the coaxial probe).
- For viscous or sticky applications, the PTFE probes are recommended. Periodic cleaning might be required.
- Maximum error due to coating is 1-10% depending on probe type, dielectric constant, coating thickness and coating height above product surface.

Coaxial	Twin Lead	Single Lead
Maximum Viscosity		
500 cP	1500 cP	8000 cP ⁽¹⁾
Coating / Build-up		
Coating not recommended	Thin coating allowed, but no bridging	Coating allowed

(1) Consult factory if agitation / turbulence and high viscosity.

Interface

Rosemount 5302 is the ideal choice for measuring the level of oil, and the interface of oil and water, or other liquids with significant dielectric differences. Rosemount 5301 can also be used in applications where the probe is fully submerged in the liquid.

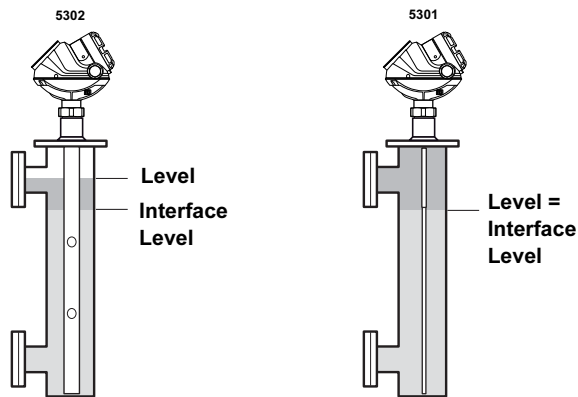

Interface Measurement with a Rosemount 5302 and a Rosemount 5301 (fully submerged probe).

When measuring interface, part of the pulse which was not reflected at the upper product surface, continues until reflected at the lower product surface. The speed of this pulse depends on the dielectric constant of the upper product.

If interface is to be measured, follow these criteria:

- The dielectric constant of the upper product must be known and should not vary. The RadarMaster software has a built-in dielectric constant calculator to help the user to estimate the upper product dielectric constant.
- The dielectric constant of the upper product must have a lower dielectric constant than the lower product.
- The difference between the dielectric constants for the two products must be larger than 6.
- Maximum dielectric constant for the upper product is 10 for the coaxial probe, 7 for the twin lead and 8 for the single lead probes.
- The upper product thickness must be larger than 5.1 in. (0.13 m) for all probes except the HTHP coaxial probe, which requires 8 in. (0.2 m), to distinguish echoes from the two liquids.

Maximum allowable upper product thickness / measuring range is primarily determined by the dielectric constants of the two liquids.

Target applications include interfaces between oil / oil-like and water / water-like liquids with low (<3) upper product dielectric constant and high (>20) lower product dielectric constant.

For such applications, the maximum measuring range is only limited by the length of the coaxial, rigid twin and rigid single lead probes.

For the flexible probes, the maximum measuring range will be reduced depending on the maximum upper product thickness according to the diagram below. The maximum interface distance is 164 ft (50 m) minus the maximum product thickness.

Maximum Upper Product Thickness for the Flexible Single Lead Probe in ft (m)

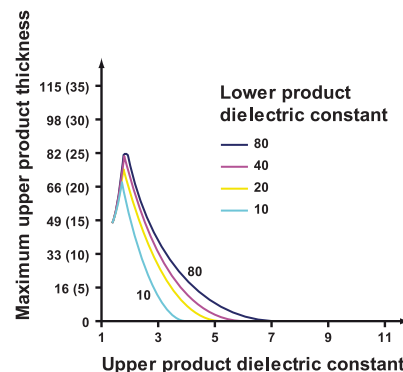

Maximum Upper Product Thickness for the Flexible Twin Lead Probe in ft (m)

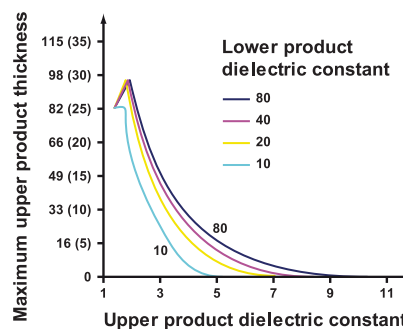

Emulsion Layer

Sometimes there is an emulsion layer (mix of the products) between the two products which can affect interface measurements. For assistance with emulsion applications, consult factory.

Product Data Sheet

00813-0100-4530, Rev AA

Catalog 2008 - 2009

Rosemount 5300 Series

Replacing a Displacer in an Existing Displacer Cage

A Rosemount 5300 Series transmitter is the perfect replacement in an existing displacer cage. Proprietary flanges are offered, enabling use of existing cages which makes installation easy.

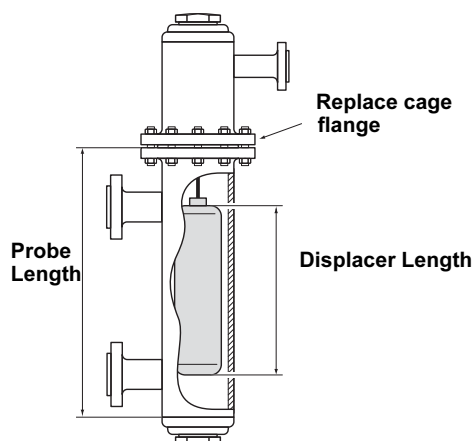

5300 Benefits

- No moving parts: Less need for maintenance - costs dramatically reduced, and as a result, also improved measurement availability.
- Reliable measurement, independent of density, turbulence, and vibrations.

Considerations when changing to 5300

When changing from a displacer to a Rosemount 5300 Series transmitter, make sure to correctly match the 5300 series flange choice and probe length to the cage. Both standard ANSI and EN (DIN) as well as proprietary cage flanges are available. See "Dimensional Drawings" on page 31 to identify the proprietary flanges.

With rigid probes, the risk of touching the tank wall is minor, so they are preferred in small diameter pipes and bypass cages.

The single lead probe is the best choice. It is excellent for interface measurements with a submerged probe. It is good for viscous and dirty liquids.

The twin lead probe has the same usage as the single probe, except it is not suitable for heavy-deposit liquids.

Both probe styles are easy to clean.

The coaxial probe measures best for low-dielectric and clean fluids. It is not recommended for submerged probe applications.

The following table gives guidelines on the required probe length.

Cage Manufacturer	Probe Length
Fisher 249B and 249C ⁽¹⁾	Displacer + 9 in. (23 cm)
Masonellan ⁽¹⁾	Displacer + 8 in. (20 cm)
Others	Displacer + 8 in. (20 cm), approximate value, length can vary

(1) See page 8 for flange rating.

Centering Discs

In order to prevent the probe from contacting the bridle wall when replacing displacers or installing in pipes, centering discs are available for stainless steel rigid single, flexible single and flexible twin lead probes. The disc is attached to the end of the probe and thus keeps the probe centered in the bridle. The discs are made of stainless steel or PTFE.

The centering disc in PTFE is not available for HTHP probes.

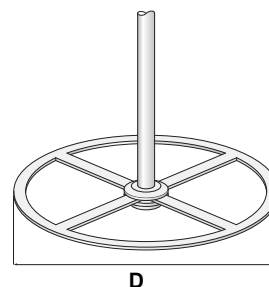

Size ⁽¹⁾	Diameter
2 in.	1.8 in. (45 mm)
3 in.	2.7 in. (68 mm)
4 in.	3.6 in. (92 mm)
6 in.	5.55 in. (141 mm)
8 in.	7.40 in. (188 mm)

(1) Centering discs can be used in pipes with material thickness up to Sch 80. If thicker, use a smaller centering disc.

Vented Flanges and Flushing Connection Rings

The 5300 Series is available with vented flanges. These flanges are designed with threaded connection (model code RA) and are ordered as accessories. As an alternative to a vented flange, it is possible to use a flushing connection ring on top of the standard nozzle (see "Special Flanges and Flushing Connection Rings" on page 31).

Solids

Rosemount 5303 is the perfect choice for most solid applications such as powders, granulates, or pellets with a grain size of up to 0.8 in. (20 mm). Material include plastics, fly-ash, cement, sand, sugar, cereals etc.

Measurements are independent of dust, moisture, and material fluctuations such as density and temperature. Even electrostatic discharges which can occur for plastics, cannot harm the 5303 transmitter.

The measured value is where the probe comes in contact with the material, which means that the shape of the material surface in the silo is not critical for the measurement.

The flexible single lead probe is recommended for solids. It is available in two versions to handle different loads and lengths:

- 0.16 in. (4 mm) in diameter.
Tensile strength is min. 2698 lb (12 kN).
Collapse load is max. 3597 lb (16 kN).
- 0.24 in. (6 mm) in diameter.
Tensile strength is min. 6519 lb (29 kN).
Collapse load is max. 7868 lb (35 kN).

It is important to keep the following in mind when planning for installation:

- In solid applications, media might cause down-pull forces on silo roofs. The silo roof must be able to withstand the probe collapse load or at least the maximum probe tensile load.
- The tensile load depends on the silo size, material density, and the friction coefficient. Forces increase with the buried length, the silo and probe diameter. In critical cases, such as for products with a risk for build-up, it is better to use a 0.24 in. (6 mm) probe.
- Depending on their position, forces on probes are generally two to ten times greater on probes with tie-down than on probes with ballast weights⁽¹⁾.

The table below shows guidelines for the tensile load from free-flowing solids acting on a suspended probe, without any tie-down or weight, in a silo with smooth metallic walls. A safety factor of 2 is included for the figures. Consult factory for more information.

NOTE:

Abrasive media can wear out the probe.
Consider using a non-contacting radar.

(1) The weight should not be fixed for 100 ft (30 m) or longer probes.

Material	Tensile load for 0.16 in. (4 mm) flexible single lead probe, lb (kN)				Tensile load for 0.24 in. (6 mm) flexible single lead probe, lb (kN)			
	Probe length 49 ft (15 m)		Probe length 115 ft (35 m)		Probe length 49 ft (15 m)		Probe length 115 ft (35 m)	
	Tank Ø= 10 ft (3 m)	Tank Ø= 39 ft (12 m)	Tank Ø= 10 ft (3 m)	Tank Ø= 39 ft (12 m)	Tank Ø= 10 ft (3 m)	Tank Ø= 39 ft (12 m)	Tank Ø= 10 ft (3 m)	Tank Ø= 39 ft (12 m)
Wheat	670 (3)	1120 (5)	1800 (8)	4500 (20). Not applicable	900 (4)	1690 (7.5)	2810 (12.5)	6740 (30). Exceeds the tensile strength limit.
Polypropylene Pellets	340 (1.5)	670 (3)	810 (3.6)	2360 (10.5)	450 (2)	920(4.1)	1190 (5.3)	3510 (15.6)
Cement	900 (4)	2020 (9)	2470 (11)	7310 (32.5). Not applicable	1350 (6)	2920 (13)	3600 (16)	10790 (48). Exceeds the tensile strength limit.

Product Data Sheet

00813-0100-4530, Rev AA

Catalog 2008 - 2009

Rosemount 5300 Series

Mechanical Considerations

Typically the transmitter is top mounted with a flanged or threaded tank connection, but the probe can also be installed at an angle of up to 90° from vertical. When the transmitter is installed, the housing can be rotated up to 360°.

The probe must be hung, fully extended, through the entire distance where level readings are desired.

To get best possible performance, the following must be considered before installing the transmitter:

- Maximum recommended nozzle height is 4 in. (10 cm) + the nozzle diameter for all probes except the coaxial. For the coaxial probe there are no such restrictions.

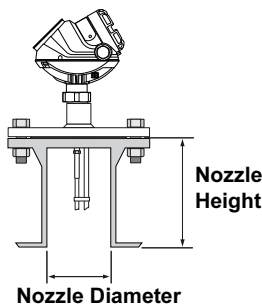

- Inlets should be kept at a distance in order to avoid product filling on the probe.

Recommended mounting position

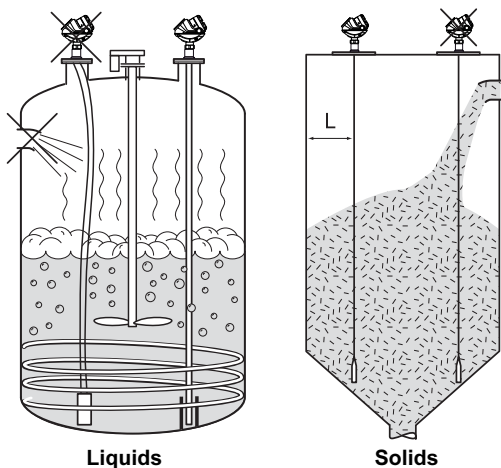

- Avoid physical contact between probes and agitators as well as applications with strong fluid movement unless the probe is anchored. If the probe can move to within 1 ft (30 cm) of any object during operation then probe tie-down is recommended.

- Select probe length according to the required measuring range. Most of the probes can be cut in field.

However, there are some restrictions for the standard and HP coaxial probes: these can be cut up to 2 ft (0.6 m). Probes shorter than 4.1 ft (1.25 m) can be cut to the minimum length of 1.3 ft (0.4 m).

The HTHP coaxial probe and the PTFE covered probes can not be cut in field.

- In order to stabilize the probe for side forces, it is possible to fix or guide the probe to the tank bottom.

For solids, consider using the 0.24 in. (6 mm) probe since it has higher tensile strength (see page Level-14). The probe should have a sag of ≥ 1 in./100 in. (1 cm/m) to prevent probe damage.

- Avoid anchoring in solids tanks over 98 ft (30 m) in height. See tensile load table in "Solids" on page 14.

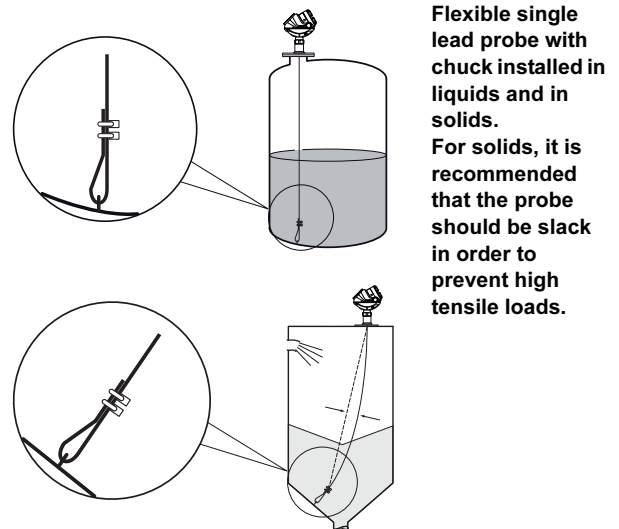

For more anchoring options, see the Reference Manual.

Rosemount 5300 Series

- For optimal single lead probe performance in non-metallic vessels, the probe must either be mounted with a 2-in. / DN 50 or larger metallic flange, or be screwed into an 8-in. (200 mm) or larger metal sheet (see the Reference Manual for placement).
- Installation on a thick concrete silo must be made flush with the lower edge, with metal shielding (see illustration to the right).
- If there is a chance the probe comes into contact with a wall, nozzle or other tank obstruction, the coaxial probe is the only recommended choice.
Minimum clearance is given in the table below.
- For solids: Installation of probes is preferably carried out when the silo is empty. Check the probe regularly for defects.

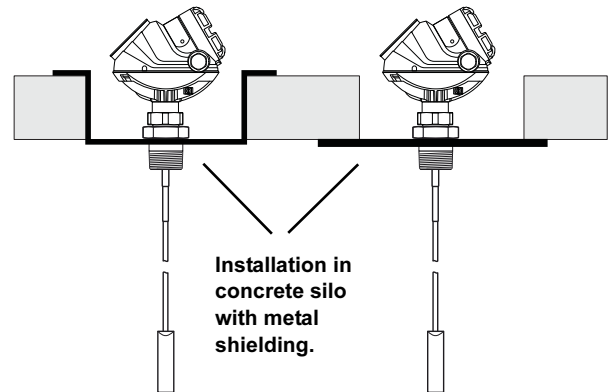

For more information on mechanical installation, see the Reference Manual (document number 00809-0100-4530)

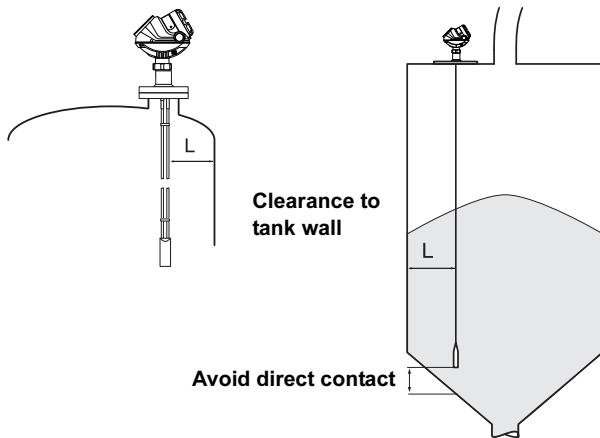

	Coaxial	Rigid Twin Lead	Flexible Twin Lead	Rigid Single Lead	Flexible Single Lead
Recommended nozzle diameter	Enough space to fit the probe	4 in. (10 cm) or more	4 in. (10 cm) or more	6 in. (15 cm) or more	6 in. (15 cm) or more
Min. nozzle diameter ⁽¹⁾	Enough space to fit the probe	2 in. (5 cm)	2 in. (5 cm)	2 in. (5 cm)	2 in. (5 cm)
Min. clearance to tank wall (L) or obstruction⁽²⁾	0 in. (0 cm)	4 in. (10 cm)	4 in. (10 cm)	4 in. (10 cm) if smooth metallic wall. 20 in. (50 cm) if disturbing objects, rugged metallic or concrete/plastic wall.	4 in. (10 cm) if smooth metallic wall. 20 in. (50 cm) if disturbing objects, rugged metallic or concrete/plastic wall.
Min. pipe / bypass diameter	1.5 in. (3.8 cm)	2 in. (5 cm) ⁽³⁾	Consult factory	2 in. (5 cm) ⁽⁴⁾	Consult factory

(1) Requires special configuration and setting of Upper Null Zone and may affect the maximum measuring range..

(2) Minimum clearance from tank bottom for the coaxial and rigid single probes is 0.2 in. (5 mm).

(3) The centermost lead must be at least 0.6 in. (15 mm) away from the pipe/bypass wall.

(4) The probe must be centered in the pipe/bypass. A centering disc (see "Centering Discs" on page 13 and "Ordering Information" on page 32) can be used to prevent the probe from contacting the bridle wall.

Specifications

General	
Product	Rosemount 5300 Series Guided Wave Radar; Model 5301, Liquid Level or Interface Transmitter (interface available for fully submerged probe). Model 5302 Liquid Level and Interface Transmitter. Model 5303 Solids Level Transmitter.
Measurement Principle	Time Domain Reflectometry (TDR).
Reference Conditions	Single standard probe, 77°F (25°C) in water and ambient pressure.
Microwave Output Power	Nominal 300 µW, Max. 45 mW.
CE-mark	Complies with applicable directives (EMC, ATEX).
Start-up Time	< 40 s
Measuring Performance	
Reference Accuracy	± 0.12 in. (3 mm) or 0.03% of measured distance, whichever is greatest. ⁽¹⁾
Repeatability	± 0.04 in. (1 mm).
Ambient Temperature Effect	± 0.008 in. (0.2 mm) /°K or ± 30 ppm/°K of measured value, whichever is greatest.
Update Interval	< 1 per second.
Measuring Range	16 in. (0.4 m) to 164 ft (50 m). See page 11 for further information.
Display / Configuration / Communication	
Integral Display	The integral digital display can toggle between: level, distance, volume, internal temperature, interface distance, interface level, peak amplitudes, interface thickness, percentage of range, analog current out. Note! The display cannot be used for configuration purposes.
Output Variables	All models: Level, Distance to Level, Volume, Level Rate, Signal Strength, Internal Temperature, Analog Output Current ⁽²⁾ and % of Range ⁽²⁾ , Model 5301 (in addition to the above for the case with fully submerged probe): Interface Level and Interface Distance. Model 5302 (in addition to the above): Interface Level, Interface Level Rate, Interface Distance, Upper Volume, Lower Volume and Upper Product Thickness.
Output Units	Level, Interface and Distance: ft, inches, m, cm or mm. Level Rate: ft/s, m/s, in./min, m/h. Volume: ft ³ , inch ³ , US gals, Imp gals, barrels, yd ³ , m ³ or liters. Temperature: °F and °C.
Configuration Tools	HART®: Rosemount RadarMaster, Rosemount 375 Field Communicator, AMS Suite or any other DD (Device Description) compatible host system. FOUNDATION™ fieldbus: Rosemount RadarMaster, Rosemount 375 Field Communicator, DeltaV® or any other DD (Device Description) compatible host system.
FOUNDATION™ fieldbus Blocks	Resource block, 3 Transducer blocks, 6 AI blocks, PID block, ISEL block, SGCR block, ARTH block, and OS block.
FOUNDATION™ fieldbus Class (Basic or Link Master)	Link Master (LAS).
FOUNDATION™ fieldbus Block Execution Time	AI-block: 30 ms. PID-block: 40 ms. ARTH-, ISEL-, OSPL-block: 65 ms. CHAR-block: 75 ms.
FOUNDATION™ fieldbus Instantiation	No.
Conforming FOUNDATION™ fieldbus	ITK 5.0.
FOUNDATION™ fieldbus PlantWeb® Alert Support	Yes.
Damping	0-60 s (2 s, default value).

Rosemount 5300 Series

Product Data Sheet
00813-0100-4530, Rev AA
Catalog 2008 - 2009

Electric	
Power Supply	HART [®] : 16-42.4 V dc (16-30 V dc in IS applications, 20-42.4 Vdc in Explosionproof / Flameproof applications). FOUNDATION [™] fieldbus: 9-32 V dc (9-30 V dc in IS applications, and 16-32 V dc in Explosionproof / Flameproof applications). FISCO, IS applications: 9-17.5 V dc.
Internal Power Consumption	< 50 mW in normal operation.
Output	HART [®] 4-20 mA current loop or FOUNDATION [™] fieldbus.
Quiescent Current Draw (FOUNDATION [™] fieldbus)	21 mA
Signal on Alarm	Standard : Low = 3.75 mA, High = 21.75 mA. Namur NE 43: Low = 3.60 mA, High = 22.50 mA.
Saturation Levels	Standard: Low = 3.9 mA, High = 20.8 mA. Namur NE 43: Low = 3.8 mA, High = 20.5 mA.
IS Parameters	See "Product Certifications" on page 21
Cable Entry	½ - 14 NPT for cable glands or conduit entries. Optional: M20 x 1.5 conduit / cable adapter, M12 4-pin male eurofast [®] connector or A size Mini 4-pin male minifast [®] connector.
Output Cabling	Twisted shielded pairs, 18-12 AWG.
Mechanical	
Probes	Coaxial: 1.3 ft (0.4 m) to 19.7 ft (6 m). Rigid Twin Lead: 1.3 ft (0.4 m) to 9.8 ft (3 m). Flexible Twin Lead: 3.3 ft (1 m) to 164 ft (50 m). Rigid Single Lead: 1.3 ft (0.4 m) to 9.8 ft (3 m). Flexible Single Lead: 3.3 ft (1 m) to 164 ft (50 m). For further information, see the probe table on page 10.
Tensile Strength	4 mm Flexible Single Lead probe (model code 5A, 5B): 2698 lb (12 kN) 6 mm Flexible Single Lead probe (model code 6A, 6B): 6519 lb (29 kN) Flexible Twin Lead probe: 2023 lb (9 kN).
Collapse Load	4 mm Flexible Single Lead probe (model code 5A, 5B): 3597 lb (16 kN) 6 mm Flexible Single Lead probe (model code 6A, 6B): 7868 lb (35 kN)
Sideway Capacity	Coaxial: 73.7 ft lbf or 3.7 lb at 19.7 ft (100 Nm or 1.67 kg at 6 m). Rigid Twin Lead: 2.2 ft lbf or 0.22 lb at 9.8 ft (3 Nm or 0.1 kg at 3 m). Rigid Single Lead: 4.4 ft lbf or 0.44 lb at 9.8 ft (6 Nm or 0.2 kg at 3 m).
Material Exposed to Tank Atmosphere	<ul style="list-style-type: none"> • 316 / 316L SST (EN 1.4404), PTFE, PFA⁽³⁾ and O-ring materials (model code 1) or • Hastelloy[®] C-276 (UNS N10276), PTFE, PFA⁽³⁾ and O-ring materials (model code 2) or • Monel[®] 400 (UNS N04400), PTFE, PFA⁽³⁾ and O-ring materials (model code 3) • PTFE⁽⁴⁾ (model code 7) or • PTFE⁽⁴⁾, 316 L SST (EN 1.4404) and O-ring materials (model code 8) • 316L SST (EN 1.4404), Ceramic (Al₂O₃), Graphite (HTHP Probe, model code H) • 316L SST (EN 1.4404), Ceramic (Al₂O₃), Graphite, PFA (HP Probe, model code P) See "Ordering Information" on page 32.
Dimensions	See "Dimensional Drawings" on page 23.
Probe Angle	0 to 90 degrees.
Housing / Enclosure	Polyurethane-covered Aluminum.
Flanges, Threads	See "Tank Connection" on page 7 and "Ordering Information" on page 32.
Height Above Flange	See "Dimensional Drawings" on page 23.
Weight	Transmitter Head (TH): 4.4 lbs (2 kg). Flange: depends on flange size. Coaxial probe: 0.67 lbs/ft (1 kg/m). Rigid Single Lead probe: 0.27 lbs/ft (0.4 kg/m). Rigid Twin Lead probe: 0.40 lbs/ft (0.6 kg/m). Flexible Single Lead probe: 0.05 lbs/ft (0.08 kg/m). Flexible Twin Lead probe: 0.09 lbs/ft (0.14 kg/m). End weight: 0.88 lbs (0.40 kg) for the 4 mm single lead probe, 1.2 lbs (0.55 kg) for the 6 mm single lead probe and 1.3 lbs (0.60 kg) for twin lead probes.

Product Data Sheet

00813-0100-4530, Rev AA

Catalog 2008 - 2009

Rosemount 5300 Series

Environment

Ambient Temperature	Non-Hazardous, HART [®] communication: -40°F to 176°F (-40°C to 80°C). IS/EEEx ia and XP/EEEx d, HART [®] communication: -40°F to 158°F (-40°C to 70°C). IS/EEEx ia and XP/EEEx d, FOUNDATION [™] fieldbus: -40°F to 140°F (-40°C to 60°C). LCD readable in: -4°F to 158°F (-20°C to 70°C).
Storage Temperature	-58°F to 194°F (-50°C to 90°C). LCD: -40°F to 185°F (-40°C to 85°C).
Process Temperature ⁽⁵⁾	Standard: -40°F to +302°F (-40°C to +150°C) HTHP: -76°F to +752°F (-60°C to +400°C) HP: -76°F to +392°F (-60°C to +200°C) See temperature and pressure diagrams on page Level-7.
Process Pressure ⁽⁵⁾	Standard: Full vacuum to 580 psig (-1 to 40 Bar). HTHP: Full vacuum to 5000 psig (-1 to 345 Bar). HP: Full vacuum to 5000 psig (-1 to 345 Bar). See temperature and pressure diagrams on page Level-7.
Humidity	0 - 100% Relative Humidity.
Ingress Protection	NEMA 4X, IP 66 and IP67.
Telecommunication (FCC and R&TTE)	FCC part 15 (1998) subpart B and R&TTE (EU directive 99/5/EC). Considered to be an unintentional radiator under the Part 15 rules.
Factory Sealed	Yes.
Vibration Resistance	Aluminum housing: IEC 60770-1 Level 1.
Electromagnetic Compatibility	Emission and Immunity: EMC directive 89/336/EEC. EN61326-1:1997 incl. A1:1998 and A2:2001. NAMUR recommendations NE21.
Built-in Lightning Protection	EN61326, IEC 801-5, level 1 kV. T1 option: the transmitter complies with IEEE 587 Category B transient protection and IEEE 472 surge protection
Pressure Equipment Directive (PED)	Complies with 97/23/EC article 3.3.

(1) For probes with spacers, the accuracy may deviate close to the spacers.

(2) Not applicable for FOUNDATION[™] fieldbus.

(3) PFA is a fluoropolymer with properties similar to PTFE.

(4) 1 mm PTFE cover.

(5) Final rating may be lower depending on flange and O-ring selection, See "Tank Connection" on page 7.

POWER SUPPLY

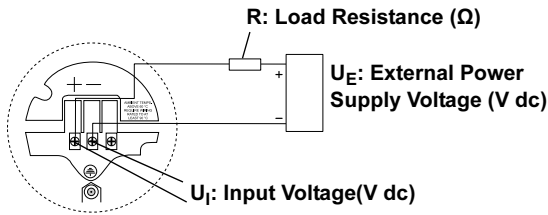

4-20 mA with HART[®]



The input voltage (U_I) for HART[®] is 16-42.4 V dc (16-30 V dc in IS applications, and 20-42.4 V dc in Explosionproof / Flameproof applications).

The maximum load resistance and power supply limitations for typical operating conditions can be obtained from the following diagrams and table.

Explosionproof / Flameproof (EEx d) Installations

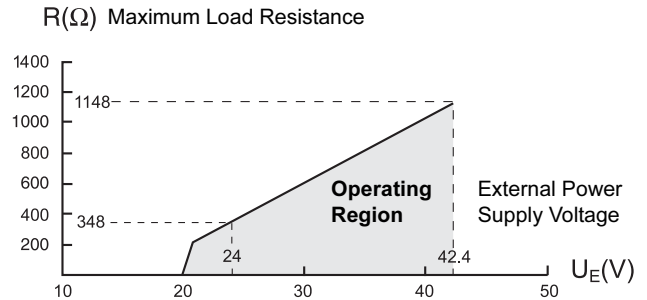

NOTE

For the EEx d case the diagram is only valid if the HART[®] load resistance is at the + side and if the - side is grounded, otherwise the load resistance value is limited to 435 Ohm.

Non-Hazardous Installations

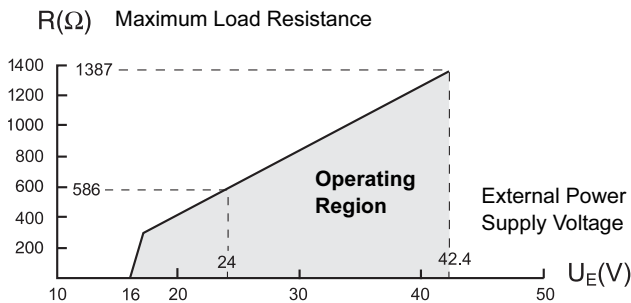

Intrinsically Safe Installations

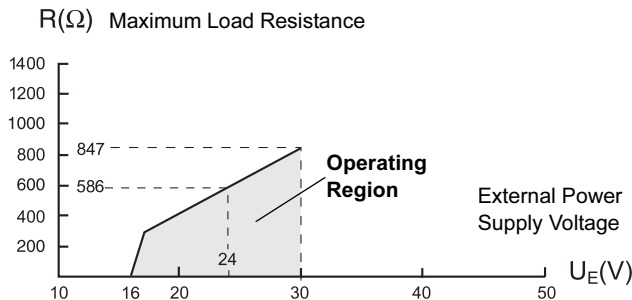

Minimum input voltage (U_I) at different currents

Hazardous approval	Current	
	3.75 mA	21.75 mA
Non-Hazardous Installations and Intrinsically Safe Installations	16 V dc	11 V dc
Explosionproof / Flameproof Installations	20 V dc	15.5 V dc

FOUNDATION[™] fieldbus



The input voltage for FOUNDATION[™] fieldbus is 9-32 V dc (9-30 V dc in IS applications, and 16-32 V dc in Explosionproof / Flameproof applications).

Product Data Sheet

00813-0100-4530, Rev AA

Catalog 2008 - 2009

Rosemount 5300 Series

Product Certifications

SAFETY NOTE

A safety isolator such as a zener barrier is always needed for intrinsic safety.

Probes covered with plastic and/or with plastic discs may generate an ignition-capable level of electrostatic charge under certain extreme conditions. Therefore, when the probe is used in a potentially explosive atmosphere, appropriate measures must be taken to prevent electrostatic discharge.

Factory Mutual (FM) Approval



Project ID: 3020497

E5 Explosion Proof for Class I, Div. 1, Groups B, C and D;
Dust Ignition Proof for Class II/III, Div. 1, Groups E, F and G;
With Intrinsically Safe connections to Class I, II, III, Div. 1, Groups B, C, D, E, F and G.
Temp. Code T4
Ambient temperature limits: -40°C to $+70^{\circ}\text{C}^{(1)}$.
Seal not required.

I5, IE Intrinsically Safe for Class I, II, III, Div. 1, Groups A, B, C, D, E, F and G,
Class I, Zone 0, AEx ia IIC T4 when installed per Control Drawing: 9240 030-936.
Non-Incendive Class I, Div. 2, Groups A, B, C and D;
Suitable for Class II, III, Div. 2, Groups F and G.
4-20 mA / HART[®] model: $U_i=30\text{ V dc}$, $I_i=130\text{ mA}$, $P_i=1.0\text{ W}$, $C_i=7.26\text{ nF}$, $L_i=0\text{ H}$.
FOUNDATION[™] fieldbus model: $U_i=30\text{ V dc}$, $I_i=300\text{ mA}$, $P_i=1.3\text{ W}$, $C_i=0\text{ nF}$, $L_i=0\text{ H}$.
FISCO model: $U_i=17.5\text{ V dc}$, $I_i=380\text{ mA}$, $P_i=5.32\text{ W}$, $L_i=C_i=0$.
Max operation:
4-20 mA / HART[®] model: 42.4 V, 25 mA,
FOUNDATION[™] fieldbus model: 32 V, 25 mA.
Temp. Code T4
Ambient temperature limits: -50°C to $+70^{\circ}\text{C}^{(1)}$

ATEX Approval

Nemko 04ATEX1073X

SPECIAL CONDITIONS FOR SAFE USE (X)

The intrinsically safe circuits do not withstand the 500 V ac test as specified in EN 50020 clause 6.4.12.

Probes covered with plastic and/or with plastic discs will have a non-conducting area that exceeds the maximum permissible areas for Group IIC and Category II 1G according to EN 50284 clause 4.4.3 (4 cm²). Therefore, when the antenna is used in a potentially explosive atmosphere, appropriate measures must be taken to prevent electrostatic discharge.

Impact and friction hazards need to be considered according to EN 50284, clause 4.3.1 when the transmitter exposed to the exterior atmosphere of the tank is made of light metal alloys, and is used in Category II 1 G.

E1 Flame Proof:
 II 1/2 GD T73°C⁽²⁾.
EEx iad IIC T4 ($-40^{\circ}\text{C} < T_a < +70^{\circ}\text{C}^{(1)}$)
 $U_m = 250\text{ V}$.

I1, IA
Intrinsically Safe:
 II 1 GD T73°C⁽²⁾.
EEx ia IIC T4 ($-50^{\circ}\text{C} < T_a < +70^{\circ}\text{C}^{(1)}$).
4-20 mA / HART[®] model: $U_i=30\text{ V dc}$, $I_i=130\text{ mA}$, $P_i=1.0\text{ W}$, $C_i=7.26\text{ nF}$, $L_i=0\text{ H}$.
FOUNDATION[™] fieldbus model: $U_i=30\text{ V dc}$, $I_i=300\text{ mA}$, $P_i=1.5\text{ W}$, $C_i=0\text{ nF}$, $L_i=0\text{ H}$.
FISCO model: $U_i=17.5\text{ V dc}$, $I_i=380\text{ mA}$, $P_i=5.32\text{ W}$, $L_i=C_i=0$.
Installation Drawing: 9240 030-938

(1) $+60^{\circ}\text{C}$ with FOUNDATION[™] fieldbus or FISCO option.

(2) $+63^{\circ}\text{C}$ with FOUNDATION[™] fieldbus or FISCO option.

Rosemount 5300 Series

Product Data Sheet
00813-0100-4530, Rev AA
Catalog 2008 - 2009

Canadian Standards Association (CSA) Approval

Cert. no. 1514653

E6 Explosionproof with internal Intrinsically Safe Circuits [Exia]
Class I, Div. 1, Groups B, C and D;
Temp Code T4.
Class II, Div. 1 and 2, Groups E, F and G;
Class III, Div. 1
Ambient temperature limits -40°C to $+70^{\circ}\text{C}^{(1)}$
Factory sealed.

I6, IF Intrinsically Safe Exia:
Class I, Div. 1, Groups A, B, C and D.
Temp Code T4.
4-20 mA / HART[®] model: $U_i=30\text{ V dc}$, $I_i=130\text{ mA}$, $P_i=1.0\text{ W}$,
 $C_i=7.3\text{ nF}$, $L_i=0\text{ H}$.
FOUNDATION[™] fieldbus model: $U_i=30\text{ V dc}$, $I_i=300\text{ mA}$,
 $P_i=1.3\text{ W}$, $C_i=0\text{ nF}$, $L_i=0\text{ H}$.
FISCO model: $U_i=17.5\text{ V dc}$, $I_i=380\text{ mA}$, $P_i=5.32\text{ W}$, $L_i=C_i=0$.

Installation Drawing: 9240 030-937
Ambient temperature limits -50°C to $+70^{\circ}\text{C}^{(1)}$.

IECEX Approval

IECEX NEM 06.0001X

CONDITIONS OF CERTIFICATION (X)

The intrinsically safe circuits do not withstand the 500 V ac test as specified in EN 50020 clause 6.4.12.

Probes covered with plastic and/or with plastic discs will have a non-conducting area that exceeds the maximum permissible areas for Group IIC according to IEC 60079-01 clause 7.3: 20 cm^2 for Zone 1, and 4 cm^2 for Zone 0. Therefore, when the probe is used in a potentially explosive atmosphere, appropriate measures must be taken to prevent electrostatic discharge.

Impact and friction hazards need to be considered according to IEC 60079-0, clause 8.1.2 when the transmitter exposed to the exterior atmosphere of the tank is made of light metal alloys, and is used in Zone 0.

E7 Flameproof:
Ex iad IIC T4 ($-40^{\circ}\text{C} < T_a < +70^{\circ}\text{C}^{(1)}$)
 $U_m = 250\text{ V}$.

I7, IG Intrinsically Safe Safety:
Ex ia IIC T4 ($-50^{\circ}\text{C} < T_a < +70^{\circ}\text{C}^{(1)}$).
4-20 mA / HART[®] model: $U_i=30\text{ V dc}$, $I_i=130\text{ mA}$, $P_i=1.0\text{ W}$,
 $C_i=7.26\text{ nF}$, $L_i=0\text{ H}$.
FOUNDATION[™] fieldbus model: $U_i=30\text{ V dc}$, $I_i=300\text{ mA}$,
 $P_i=1.5\text{ W}$, $C_i=0\text{ nF}$, $L_i=0\text{ H}$.
FISCO model: $U_i=17.5\text{ V dc}$, $I_i=380\text{ mA}$, $P_i=5.32\text{ W}$, $L_i=C_i=0$.
Installation Drawing: 9240 030-938

Combination Approvals

KA ATEX, FM, CSA Flameproof/Explosionproof
KB ATEX, FM, IECEx Flameproof/Explosionproof
KC ATEX, CSA, IECEx Flameproof/Explosionproof
KD FM, CSA, IECEx Flameproof/Explosionproof
KE ATEX, FM, CSA Intrinsic Safety
KF ATEX, FM, IECEx Intrinsic Safety
KG ATEX, CSA, IECEx Intrinsic Safety
KH FM, CSA, IECEx Intrinsic Safety
KI FISCO - ATEX, FM, CSA Intrinsic Safety
KJ FISCO - ATEX, FM, IECEx Intrinsic Safety
KK FISCO - ATEX, CSA, IECEx Intrinsic Safety
KL FISCO - FM, CSA, IECEx Intrinsic Safety

For detailed information, refer to the Reference Manual (document number 00809-0100-4530).

(1) $+60^{\circ}\text{C}$ with FOUNDATION[™] fieldbus or FISCO option.

Dimensional Drawings

Dimensions are in inches
(millimeters)

COAXIAL PROBE WITH FLANGE CONNECTION

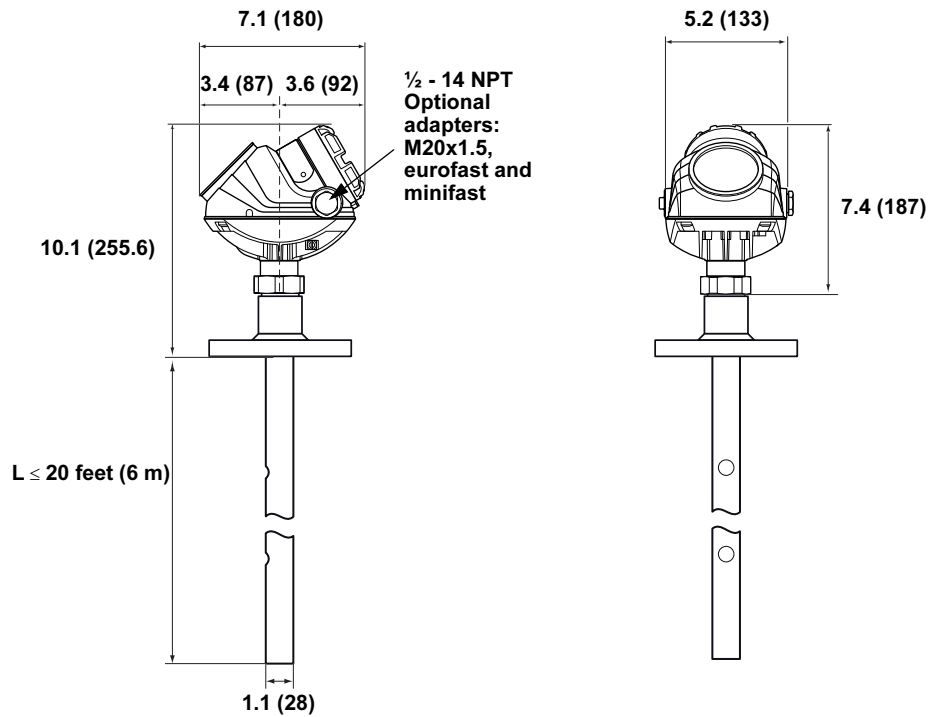

HThP/HP version

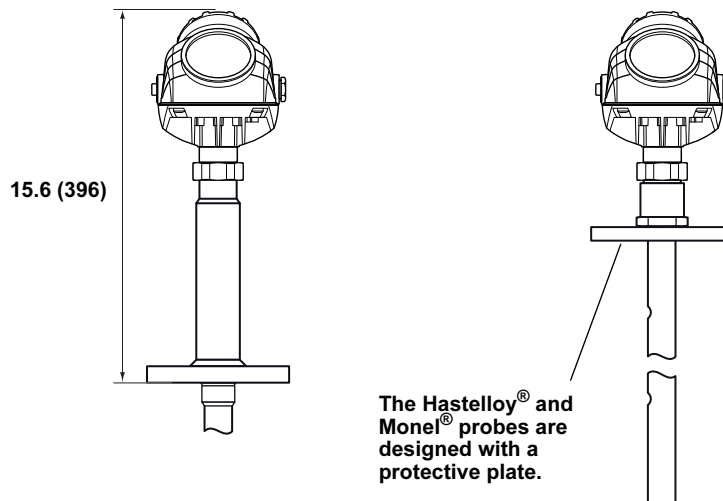

Rosemount 5300 Series

COAXIAL PROBE WITH THREADED CONNECTION

Dimensions are in inches
(millimeters)

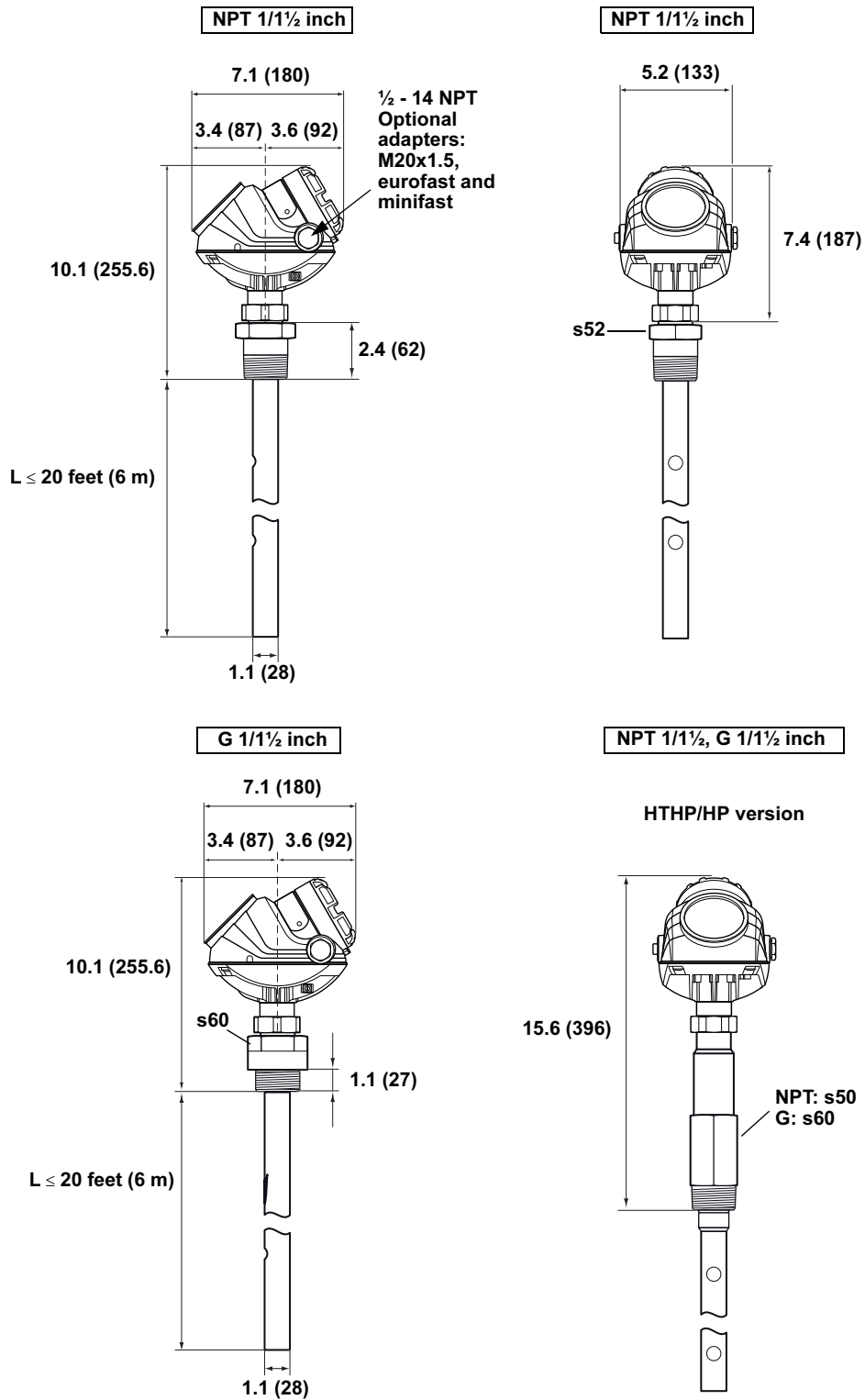

Product Data Sheet

00813-0100-4530, Rev AA

Catalog 2008 - 2009

Rosemount 5300 Series

RIGID TWIN LEAD PROBE

Dimensions are in inches
(millimeters)

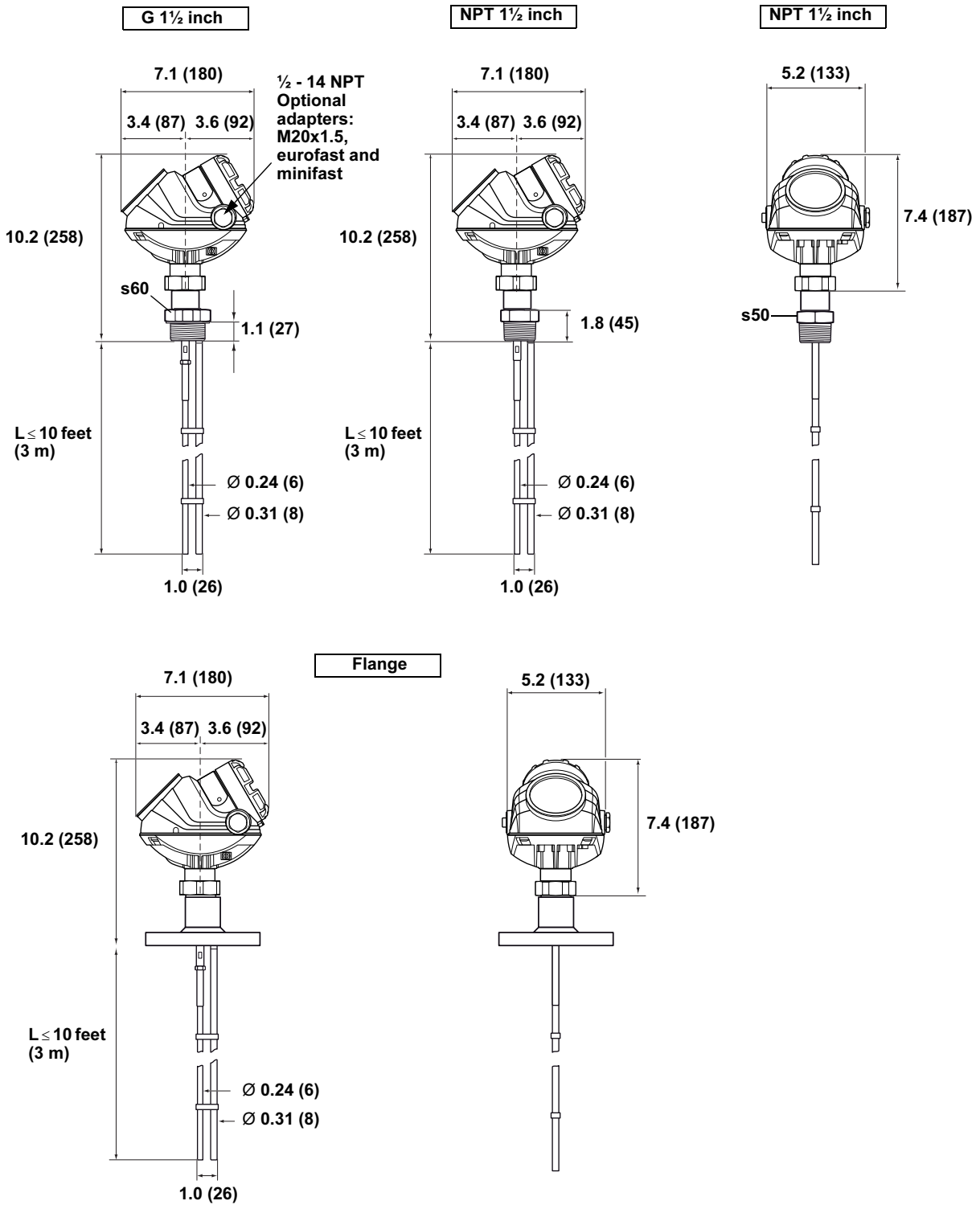

RIGID SINGLE LEAD PROBE WITH FLANGE CONNECTION

Dimensions are in inches
 (millimeters)

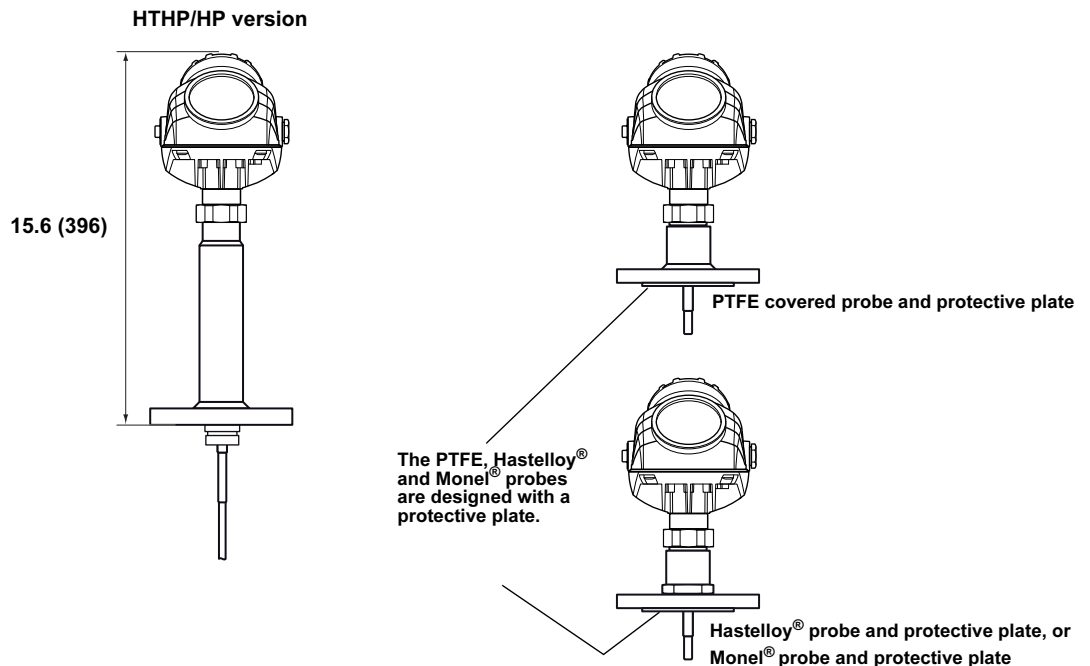
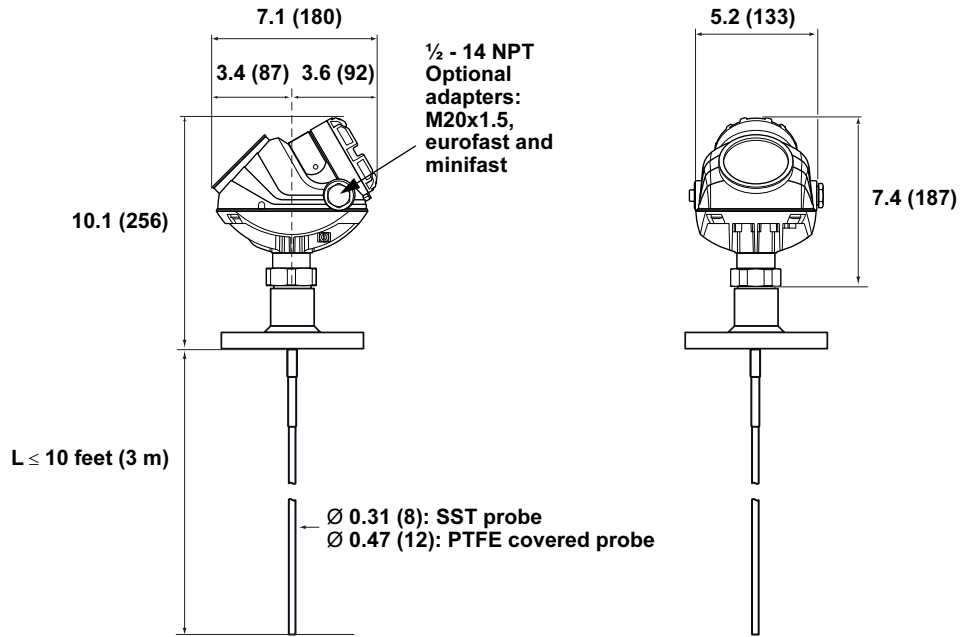

Rosemount 5300 Series

Product Data Sheet
 00813-0100-4530, Rev AA
 Catalog 2008 - 2009

RIGID SINGLE LEAD PROBE WITH THREADED CONNECTION

Dimensions are in inches
 (millimeters)

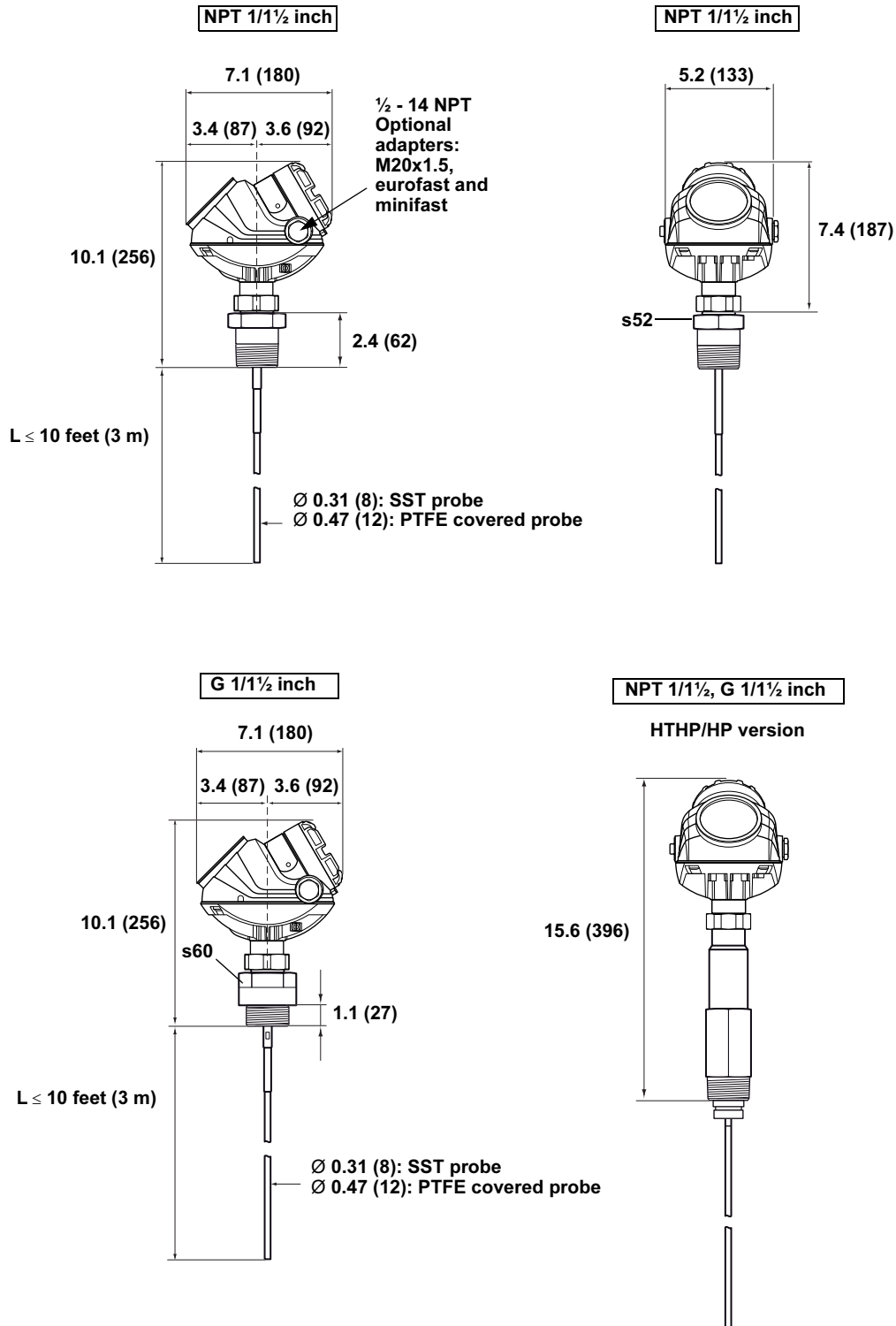

Product Data Sheet

00813-0100-4530, Rev AA
Catalog 2008 - 2009

Rosemount 5300 Series

FLEXIBLE SINGLE LEAD PROBE WITH FLANGE CONNECTION

Dimensions are in inches
(millimeters)

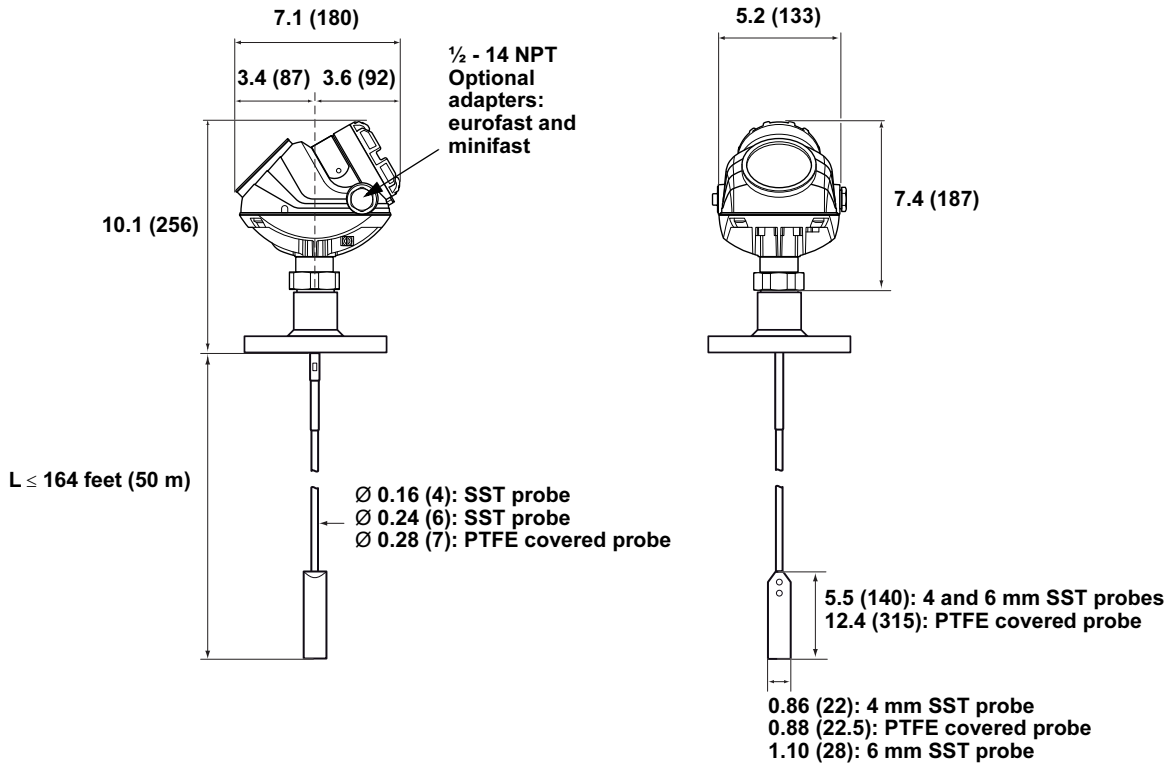

HTHP/HP version

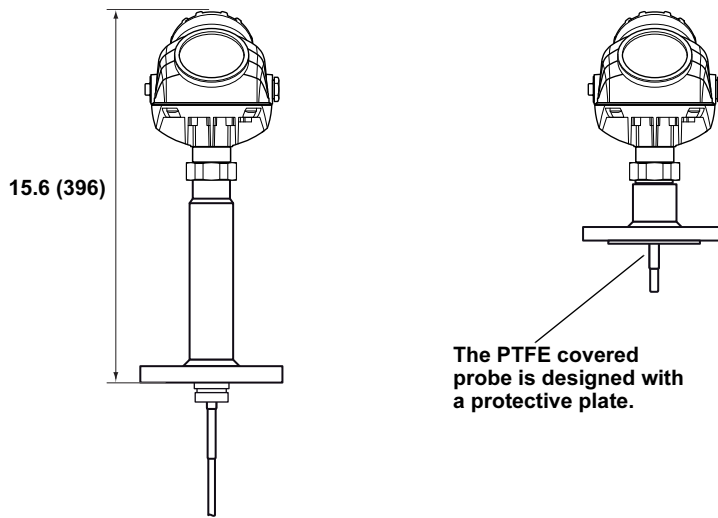

Rosemount 5300 Series

Product Data Sheet
 00813-0100-4530, Rev AA
 Catalog 2008 - 2009

FLEXIBLE SINGLE LEAD PROBE WITH THREADED CONNECTION

Dimensions are in inches
 (millimeters)

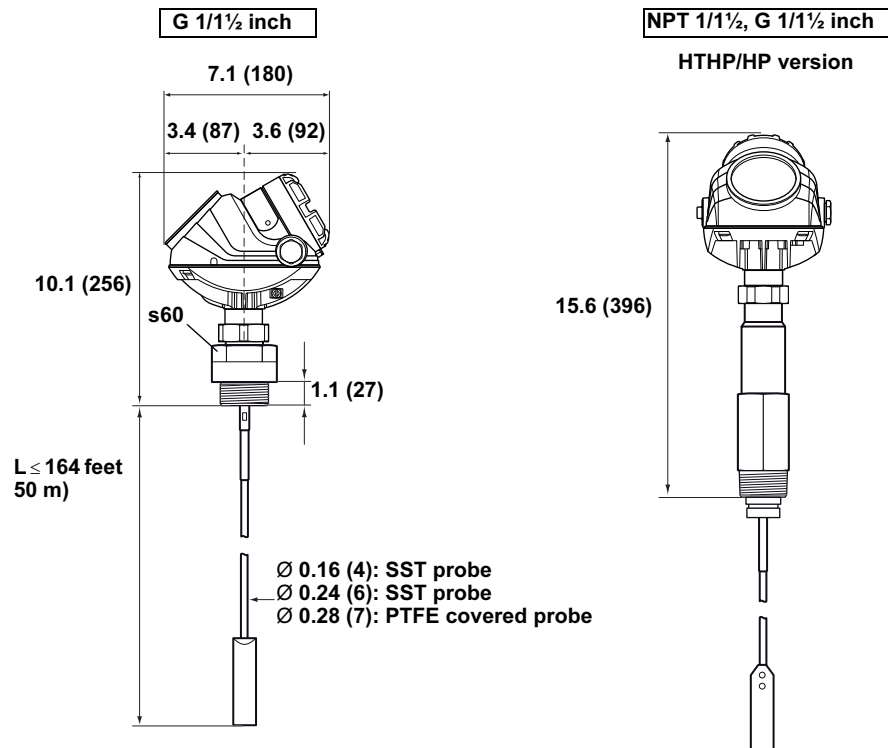
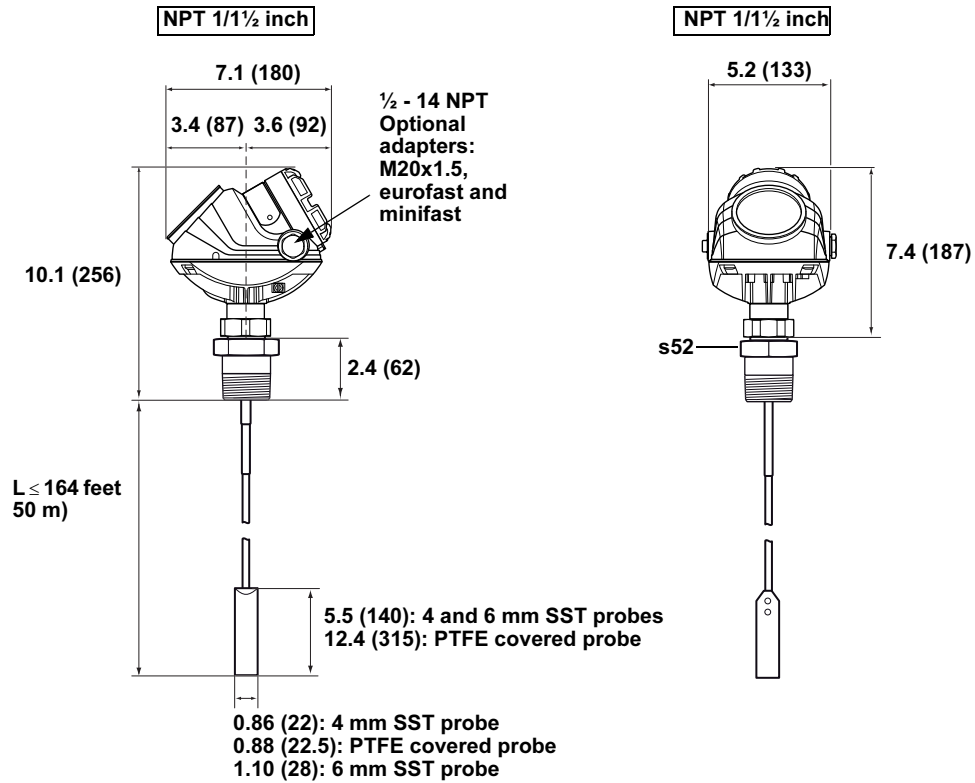

Product Data Sheet

00813-0100-4530, Rev AA
 Catalog 2008 - 2009

Rosemount 5300 Series

SPECIAL FLANGES AND FLUSHING CONNECTION RINGS

Dimensions are in inches
 (millimeters)

Raised Face

Recessed Face

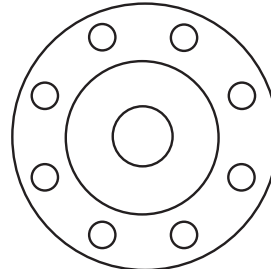
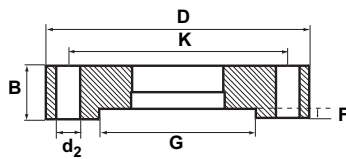
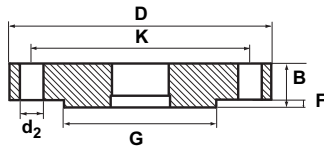

D: Outside diameter
B: Flange thickness
F: Raised Face
G: Face diameter
Bolts: Number of Bolts
K: Bolt hole circle diameter
d₂: Hole diameter

NOTE

Dimensions may be used to aid in the identification of installed flanges. It is not intended for manufacturing use.

Special Flanges ⁽¹⁾	D	B ₁	B ₂	F	G	# Bolts	K	N
Fisher 249B/259B ⁽²⁾	9.00 (228.6)	1.50 (38.2)	1.25 (31.8)	0.25 (6.4)	5.23 (132.8)	8	7.25 (184.2)	NA
Fisher 249C ⁽³⁾	5.69 (144.5)	0.94 (23.8)	1.13 (28.6)	-0.19 (-4.8)	3.37 (85.7)	8	4.75 (120.65)	NA
Masoneilan ⁽²⁾	7.51 (191.0)	1.54 (39.0)	1.30 (33.0)	0.24 (6.0)	4.02 (102.0)	8	5.87 (149.0)	NA

- (1) These flanges are also available in a vented version.
- (2) Flange with raised face.
- (3) Flange with recessed face.

Masoneilan and Fisher flanges are also available in vented versions (see "Accessories" on page 39), with the same dimensions as shown in the table above.

Vented flanges must be ordered with a 1 ½ in. NPT threaded process connection (code RA).

For information about flange temperature and pressure ratings, see page Level-7.

Flushing Connection Ring

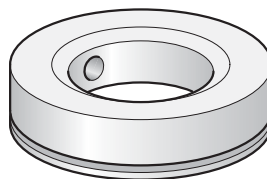
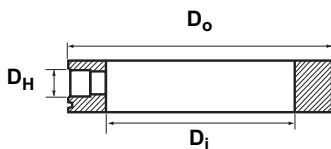

Flushing Connection Rings	D _i	D _o	D _H
2 in. ANSI	2.12 (53.8)	3.62 (91.9)	¼ in. NPT
3 in. ANSI	3.60 (91.4)	5.00 (127.0)	¼ in. NPT
4 in. ANSI	3.60 (91.4)	6.20 (157.5)	¼ in. NPT
DN50	2.40 (61.0)	4.00 (102.0)	¼ in. NPT
DN80	3.60 (91.4)	5.43 (138.0)	¼ in. NPT

Ordering Information

MODEL CODE 5301 AND 5302 LEVEL AND/OR INTERFACE IN LIQUIDS

Model	Product Description		
5301	Guided Wave Radar Liquid Level or Interface Transmitter (interface available for fully submerged probe)		
5302	Guided Wave Radar Liquid Level and Interface Transmitter		
Code	Signal Output		
H	4-20 mA with HART® communication		
F	FOUNDATION™ fieldbus		
Code	Housing Material		
A	Polyurethane-covered Aluminum		
Code	Conduit / Cable Threads		
1	½ - 14 NPT		
2	M20 x 1.5 adapter		
E	M12, 4-pin, Male connector (eurofast®) ⁽¹⁾		
M	A size Mini, 4-pin, Male connector (minifast®) ⁽¹⁾		
Code	Operating Temperature and Pressure ⁽²⁾	Probe Type	
S	- 15 psig (-1bar) to 580 psig (40 bar) @ 302 °F (150 °C)	All	
H	High Temp / High Pressure ⁽³⁾ : 2940 psi @ 752 °F and 5000 psi @ 100 °F (203 bar @ 400 °C and 345 bar @ 38 °C) according to ANSI Class 2500	3A, 3B, 4A, 5A and 5B (only SST)	
P	High Pressure ⁽³⁾ : Max 392 °F (200 °C): 3500 psi @ 392 °F and 5000 psi @ 100 °F (243 bar @ 200 °C and 345 bar @ 38 °C) according to ANSI Class 2500	3A, 3B, 4A, 5A and 5B (only SST)	
Code	Material of Construction ⁽⁴⁾ : Process Connection / Probe	Probe Type	
1	316 / 316 L SST (EN 1.4404)	All	
2	Hastelloy® C-276 (UNS N10276). With plate design if flanged version.	3A, 3B, 4A	
3	Monel® 400 (UNS N04400). With plate design if flanged version.	3A, 3B, 4A	
7	PTFE covered probe and flange. With plate design.	4A and 5A	
8	PTFE covered probe	4A and 5A	
Code	Sealing, O-ring Material (Consult factory for other o-ring materials)		
N	None ⁽⁵⁾		
V	Viton® fluoroelastomer		
E	Ethylene Propylene		
K	Kalrez® 6375 perfluoroelastomer		
B	Buna-N		
Code	Probe Type	Process Connection	Probe Lengths
1A	Rigid Twin Lead ⁽⁷⁾	Flange or 1.5 in. Thread	Min: 1 ft 4 in. (0.4 m). Max: 9 ft 10 in. (3 m)
2A	Flexible Twin Lead with weight ⁽⁷⁾	Flange or 1.5 in. Thread	Min: 3 ft 4 in. (1 m). Max: 164 ft (50 m)
3A	Coaxial (for level measurement) ⁽⁶⁾	Flange, 1 ⁽⁷⁾ or 1.5 in. Thread	Min: 1 ft 4 in. (0.4 m). Max: 19 ft 8 in. (6 m)
3B	Coaxial, perforated. For level and interface measurement, or easier cleaning.	Flange, 1 ⁽⁷⁾ or 1.5 in. Thread	Min: 1 ft 4 in. (0.4 m). Max: 19 ft 8 in. (6 m)
4A	Rigid Single Lead	Flange, 1 ⁽⁷⁾ or 1.5 in. Thread	Min: 1 ft 4 in. (0.4 m). Max: 9 ft 10 in. (3 m)
5A	Flexible Single Lead with weight	Flange, 1 ⁽⁷⁾ or 1.5 in. Thread	Min: 3 ft 4 in. (1 m). Max: 164 ft (50 m)
5B	Flexible Single Lead with chuck ⁽⁸⁾	Flange, 1 ⁽⁷⁾ or 1.5 in. Thread	Min: 3 ft 4 in. (1 m). Max: 164 ft (50 m)
Code	Probe Length Units		
E	English (feet, in.)		
M	Metric (meters, centimeters)		

Product Data Sheet

00813-0100-4530, Rev AA

Catalog 2008 - 2009

Rosemount 5300 Series

Code		Total Probe Length ⁽⁹⁾ (feet/m)
xxx		0-164 ft or 0-50 m
Code		Total Probe Length ⁽⁹⁾ (in./cm)
xx		0-11 in. or 0-99 cm
Code Process Connection - Size / Type (consult factory for other process connections)		
ANSI Flanges in 316L SST (EN 1.4404)		
AA		2 in. ANSI, 150 lb
AB		2 in. ANSI, 300 lb
AC		2 in. ANSI, 600 lb. HTHP / HP units
AD		2 in. ANSI, 900 lb. HTHP / HP units
AE		2 in. ANSI, 1500 lb. HTHP / HP units
AI		2 in. ANSI, 600 lb, RTJ (Ring Type Joint). HTHP / HP units
AJ		2 in. ANSI, 900 lb, RTJ (Ring Type Joint). HTHP / HP units
AK		2 in. ANSI, 1500 lb, RTJ (Ring Type Joint). HTHP / HP units
BA		3 in. ANSI, 150 lb
BB		3 in. ANSI, 300 lb
BC		3 in. ANSI, 600 lb. HTHP / HP units
BD		3 in. ANSI, 900 lb. HTHP / HP units
BE		3 in. ANSI, 1500 lb. HTHP / HP units
BI		3 in. ANSI, 600 lb, RTJ (Ring Type Joint). HTHP / HP units
BJ		3 in. ANSI, 900 lb, RTJ (Ring Type Joint). HTHP / HP units
BK		3 in. ANSI, 1500 lb, RTJ (Ring Type Joint). HTHP / HP units
CA		4 in. ANSI, 150 lb
CB		4 in. ANSI, 300 lb
CC		4 in. ANSI, 600 lb. HTHP / HP units
CD		4 in. ANSI, 900 lb. HTHP / HP units
CE		4 in. ANSI, 1500 lb. HTHP / HP units
CI		4 in. ANSI, 600 lb, RTJ (Ring Type Joint). HTHP / HP units
CJ		4 in. ANSI, 900 lb, RTJ (Ring Type Joint). HTHP / HP units
CK		4 in. ANSI, 1500 lb, RTJ (Ring Type Joint). HTHP / HP units
DA		6 in. ANSI, 150 lb
EN (DIN) Flanges in 316L SST (EN 1.4404)		
HB		DN50, PN40
HC		DN50, PN63. HTHP / HP units
HD		DN50, PN100. HTHP / HP units
HE		DN50, PN160. HTHP / HP units
HF		DN50, PN250. HTHP / HP units
IA		DN80, PN16
IB		DN80, PN40
IC		DN80, PN63 . HTHP / HP units
ID		DN80, PN100. HTHP / HP units
IE		DN80, PN160. HTHP / HP units
IF		DN80, PN250. HTHP / HP units
JA		DN100, PN16
JB		DN100, PN40
JC		DN100, PN63. HTHP / HP units
JD		DN100, PN100. HTHP / HP units

Rosemount 5300 Series

Product Data Sheet
00813-0100-4530, Rev AA
Catalog 2008 - 2009

Code	Process Connection - Size / Type (consult factory for other process connections)	
JE	DN100, PN160. HTHP / HP units	
JF	DN100, PN250. HTHP / HP units	
KA	DN150, PN16	
JIS Flanges in 316L SST (EN 1.4404)		
UA	50A, 10K	
UB	50A, 20K	
VA	80A, 10K	
VB	80A, 20K	
XA	100A, 10K	
XB	100A, 20K	
YA	150A, 10K	
YB	150A, 20K	
ZA	200A, 10K	
ZB	200A, 20K	
Threaded Connections		Probe Type
RA	1 ½ in. NPT thread	All
RB	1 in. NPT thread	3A, 3B, 4A, 5A, 5B, standard temperature and pressure
SA	1 ½ in. BSP (G 1 ½ in.) thread	All
SB	1 in. BSP (G 1 in.) thread	3A, 3B, 4A, 5A, 5B, standard temperature and pressure
Proprietary Flanges		
TF	Fisher - proprietary 316L SST (for 249B cages) Torque Tube Flange	
TT	Fisher - proprietary 316L SST (for 249C cages) Torque Tube Flange	
TM	Masoneilan - proprietary 316L SST Torque Tube Flange	
Code	Hazardous Locations Certifications	
NA	No Hazardous Locations Certifications	
E1	ATEX Flameproof	
E5	FM Explosion Proof	
E6	CSA Explosion Proof	
E7	IECEX Flameproof	
I1	ATEX Intrinsic Safety	
IA	ATEX FISCO Intrinsic Safety ⁽¹⁰⁾	
I5	FM Intrinsic Safety and Non-Incendive	
IE	FM FISCO Intrinsic Safety ⁽¹⁰⁾	
I6	CSA Intrinsic Safety	
IF	CSA FISCO Intrinsic Safety ⁽¹⁰⁾	
I7	IECEX Intrinsic Safety	
IG	IECEX FISCO Intrinsic Safety ⁽¹⁰⁾	
KA	ATEX, FM, CSA Flameproof/Explosionproof	
KB	ATEX, FM, IECEX Flameproof/Explosionproof	
KC	ATEX, CSA, IECEX Flameproof/Explosionproof	
KD	FM, CSA, IECEX Flameproof/Explosionproof	
KE	ATEX, FM, CSA Intrinsic Safety	
KF	ATEX, FM, IECEX Intrinsic Safety	
KG	ATEX, CSA, IECEX Intrinsic Safety	

Product Data Sheet

00813-0100-4530, Rev AA

Catalog 2008 - 2009

Rosemount 5300 Series

Code		Hazardous Locations Certifications	
KH		FM, CSA, IECEx Intrinsic Safety	
KI		FISCO - ATEX, FM, CSA Intrinsic Safety ⁽¹⁰⁾	
KJ		FISCO - ATEX, FM, IECEx Intrinsic Safety ⁽¹⁰⁾	
KK		FISCO - ATEX, CSA, IECEx Intrinsic Safety ⁽¹⁰⁾	
KL		FISCO - FM, CSA, IECEx Intrinsic Safety ⁽¹⁰⁾	
Code		Options	
M1		Integral digital display	
P1		Hydrostatic testing ⁽¹¹⁾	
N2		NACE material recommendation per MR-0175 ⁽¹²⁾	
LS		Long stud ⁽¹³⁾ 9.8 in (250 mm) for flexible single lead probe to prevent contact with wall/nozzle. Standard height is 3.9 in (100 mm) for probes 5A and 5B.	
T1		Transient Protection Terminal Block (standard with FISCO options)	
Sx and Px - Centering Discs		Outer Diameter	
S2	2 in. Centering disc SST ⁽¹⁴⁾	1.8 in. (45 mm)	
S3	3 in. Centering disc SST ⁽¹⁴⁾	2.7 in. (68 mm)	
S4	4 in. Centering disc SST ⁽¹⁴⁾	3.6 in. (92 mm)	
S6	6 in. Centering disc SST ⁽¹⁴⁾	5.55 in. (141 mm)	
S8	8 in. Centering disc SST ⁽¹⁴⁾	7.40 in. (188 mm)	
P2	2 in. Centering disc PTFE ⁽¹⁵⁾	1.8 in. (45 mm)	
P3	3 in. Centering disc PTFE ⁽¹⁵⁾	2.7 in. (68 mm)	
P4	4 in. Centering disc PTFE ⁽¹⁵⁾	3.6 in. (92 mm)	
P6	6 in. Centering disc PTFE ⁽¹⁵⁾	5.55 in. (141 mm)	
P8	8 in. Centering disc PTFE ⁽¹⁵⁾	7.40 in. (188 mm)	
Cx - Special Configuration (Software)			
C1	Factory configuration (CDS required with order)		
C4	Namur alarm and saturation levels, high alarm		
C5	Namur alarm and saturation levels, low alarm		
C8	Low alarm ⁽¹⁶⁾ (standard Rosemount alarm and saturation levels)		
Qx - Special Certifications			
Q4	Calibration Data Certification		
Q8	Material Traceability Certification per EN 10204 3.1 ⁽¹⁷⁾		

(1) Not available with Flame/Explosionproof approvals (E1, E5, E6, E7, KA, KB, KC, and KD)

(2) Process seal rating. Final rating depends on flange and O-ring selection. See "Tank Connection" on page 7.

(3) Requires option None for sealing (no O-ring). Only for SST ("Material of Construction", code 1).

(4) For other materials, consult factory.

(5) Requires High Temperature High Pressure (code H) or High Pressure (code P) probe.

(6) Requires model 5301.

(7) Only available with standard temperature and pressure (code S).

(8) Extra length for fastening is added in factory.

(9) Probe weight included if applicable. Give the total probe length in feet and inches or meters and centimeters, depending on selected probe length unit. If tank height is unknown, please round up to an even length when ordering. Probes can be cut to exact length in field. Maximum allowable length is determined by process conditions. See "Mechanical Considerations" on page 15 for more probe length guidance.

(10) Requires Foundation™ fieldbus signal output (U_j parameter listed in "Product Certifications" on page 21).

(11) For standard tank connection, only available with flange.

(12) Valid for probe type 3A, 3B and 4A.

(13) Not available with PTFE covered probes.

(14) Available for SST probes, type 2A, 4A and 5A. For more information, see "Centering Discs" on page 13.

(15) Available for SST probes, type 2A, 4A and 5A, except for HTHP.

(16) The standard alarm setting is high.

(17) Certificate includes all pressure retaining wetted parts.

Example Model String: 5301-H-A-1-S-1-V-1A-M-002-05-AA-I1-M1C1. E-002-05, means 2 ft and 5 in. probe length. M-002-05, means 2.05 m.

Rosemount 5300 Series

Product Data Sheet
00813-0100-4530, Rev AA
Catalog 2008 - 2009

MODEL CODE 5303, LEVEL FOR SOLIDS

Model	Product Description		
5303	Guided Wave Solids Level Transmitter		
Code	Signal Output		
H	4-20 mA with HART® communication		
F	FOUNDATION™ fieldbus		
Code	Housing Material		
A	Polyurethane-covered Aluminum		
Code	Conduit / Cable Threads		
1	½ - 14 NPT		
2	M20 x 1.5 adapter		
E	M12, 4-pin, Male connector (eurofast®)(1)		
M	A size Mini, 4-pin, Male connector (minifast®)(1)		
Code	Operating Temperature and Pressure	Probe Type	
S	- 15 psig (-1bar) to 580 psig (40 bar) @ 302 °F (150 °C) (2)	All	
Code	Material of Construction(3): Process Connection / Probe	Probe Type	
1	316 / 316 L SST (EN 1.4404)	All	
Code	Sealing, O-ring Material (Consult factory for other o-ring materials)		
V	Viton® fluoroelastomer		
E	Ethylene Propylene		
K	Kalrez® 6375 perfluoroelastomer		
B	Buna-N		
Code	Probe Type	Process Connection	Probe Lengths
5A	Flexible Single Lead with weight, 4 mm	Flange, 1 or 1.5 in. Thread	Min: 3 ft 4 in. (1 m). Max: 115 ft. (35 m)
5B	Flexible Single Lead with chuck, 4 mm(4)	Flange, 1 or 1.5 in. Thread	Min: 3 ft 4 in. (1 m). Max: 115 ft. (35 m)
6A	Flexible Single Lead with weight, 6 mm	Flange, 1 or 1.5 in. Thread	Min: 3 ft 4 in. (1 m). Max: 164 ft. (50 m)
6B	Flexible Single Lead with chuck, 6 mm(4)	Flange, 1 or 1.5 in. Thread	Min: 3 ft 4 in. (1 m). Max: 164 ft. (50 m)
Code	Probe Length Units		
E	English (feet, in.)		
M	Metric (meters, centimeters)		
Code	Total Probe Length (5) (feet/m)		
xxx	0-164 ft or 0-50 m		
Code	Total Probe Length (5) (in./cm)		
xx	0-11 in. or 0-99 cm		

Product Data Sheet

00813-0100-4530, Rev AA

Catalog 2008 - 2009

Rosemount 5300 Series

Code		Process Connection - Size / Type (consult factory for other process connections)
ANSI Flanges in 316L SST (EN 1.4404)		
AA	2 in. ANSI, 150 lb	
AB	2 in. ANSI, 300 lb	
BA	3 in. ANSI, 150 lb	
BB	3 in. ANSI, 300 lb	
CA	4 in. ANSI, 150 lb	
CB	4 in. ANSI, 300 lb	
DA	6 in. ANSI, 150 lb	
EN (DIN) Flanges in 316L SST (EN 1.4404)		
HB	DN50, PN40	
IA	DN80, PN16	
IB	DN80, PN40	
JA	DN100, PN16	
JB	DN100, PN40	
KA	DN150, PN16	
JIS Flanges in 316L SST (EN 1.4404)		
UA	50A, 10K	
UB	50A, 20K	
VA	80A, 10K	
VB	80A, 20K	
XA	100A, 10K	
XB	100A, 20K	
YA	150A, 10K	
YB	150A, 20K	
ZA	200A, 10K	
ZB	200A, 20K	
Threaded Connections		Probe Type
RA	1 ½ in. NPT thread	All
RB	1 in. NPT thread	4A, 5A, 5B, 6A, 6B standard temperature and pressure
SA	1 ½ in. BSP (G 1 ½ in.) thread	All
SB	1 in. BSP (G 1 in.) thread	4A, 5A, 5B, 6A, 6B standard temperature and pressure

Rosemount 5300 Series

Product Data Sheet
00813-0100-4530, Rev AA
Catalog 2008 - 2009

Hazardous Locations Certifications	
NA	No Hazardous Locations Certifications
E1	ATEX Flameproof
E5	FM Explosion Proof
E6	CSA Explosion Proof
E7	IECEX Flameproof
I1	ATEX Intrinsic Safety
IA	ATEX FISCO Intrinsic Safety ⁽⁶⁾
I5	FM Intrinsic Safety and Non-Incendive
IE	FM FISCO Intrinsic Safety ⁽⁶⁾
I6	CSA Intrinsic Safety
IF	CSA FISCO Intrinsic Safety ⁽⁶⁾
I7	IECEX Intrinsic Safety
IG	IECEX FISCO Intrinsic Safety ⁽⁶⁾
KA	ATEX, FM, CSA Flameproof/Explosionproof
KB	ATEX, FM, IECEX Flameproof/Explosionproof
KC	ATEX, CSA, IECEX Flameproof/Explosionproof
KD	FM, CSA, IECEX Flameproof/Explosionproof
KE	ATEX, FM, CSA Intrinsic Safety
KF	ATEX, FM, IECEX Intrinsic Safety
KG	ATEX, CSA, IECEX Intrinsic Safety
KH	FM, CSA, IECEX Intrinsic Safety
KI	FISCO - ATEX, FM, CSA Intrinsic Safety ⁽⁶⁾
KJ	FISCO - ATEX, FM, IECEX Intrinsic Safety ⁽⁶⁾
KK	FISCO - ATEX, CSA, IECEX Intrinsic Safety ⁽⁶⁾
KL	FISCO - FM, CSA, IECEX Intrinsic Safety ⁽⁶⁾
Options	
M1	Integral digital display
P1	Hydrostatic testing ⁽⁷⁾
LS	Long stud 9.8 in (250 mm) for flex. single lead probe to prevent contact with wall/nozzle. Standard height is 3.9 in (100 mm) for probes 5A and 5B; 5.9 in. (150 mm) for probes 6A and 6B.
T1	Transient Protection Terminal Block (standard with FISCO options)
Cx - Special Configuration (Software)	
C1	Factory configuration (CDS required with order)
C4	Namur alarm and saturation levels, high alarm
C5	Namur alarm and saturation levels, low alarm
C8	Low alarm ⁽⁸⁾ (standard Rosemount alarm and saturation levels)
Qx - Special Certifications	
Q4	Calibration Data Certification
Q8	Material Traceability Certification per EN 10204 3.1 ⁽⁹⁾

(1) Not available with Flame/Explosionproof approvals (E1, E5, E6, E7, KA, KB, KC, and KD)

(2) Process seal rating. Final rating depends on flange and O-ring selection. See "Tank Connection" on page 7.

(3) For other materials, consult factory.

(4) Extra length for fastening is added in factory.

(5) Probe weight included if applicable. Give the total probe length in feet and inches or meters and centimeters, depending on selected probe length unit. If tank height is unknown, please round up to an even length when ordering. Probes can be cut to exact length in field. Maximum allowable length is determined by process conditions. See "Mechanical Considerations" on page 15 for more probe length guidance.

(6) Requires Foundation™ fieldbus signal output (U_i parameter listed in "Product Certifications" on page 21).

(7) Available for flanged connection.

(8) The standard alarm setting is high.

(9) Certificate includes all pressure retaining wetted parts.

Example Model String: 5303-H-A-1-S-1-V-6A-M-025-50-AA-I1-M1C1. E-025-05, means 25 ft and 5 in. probe length. M-025-50, means 25.5 m.

Product Data Sheet

00813-0100-4530, Rev AA

Catalog 2008 - 2009

Rosemount 5300 Series

ACCESSORIES

Code	Process Connection - Size/Type (consult factory for other process connections)	
Centering discs⁽¹⁾		Outer Diameter
03300-1655-0001	Kit, 2-in. Centering Disk, SST, Rigid Single	1.8 in. (45 mm)
03300-1655-0002	Kit, 3-in. Centering Disk, SST, Rigid Single	2.7 in. (68 mm)
03300-1655-0003	Kit, 4-in. Centering Disk, SST, Rigid Single	3.6 in. (92 mm)
03300-1655-0004	Kit, 6-in. Centering Disk, SST, Rigid Single	5.55 in. (141 mm)
03300-1655-0005	Kit, 8-in. Centering Disk, SST, Rigid Single	7.40 in. (188 mm)
03300-1655-0006	Kit, 2-in. Centering Disk, PTFE, Rigid Single	1.8 in. (45 mm)
03300-1655-0007	Kit, 3-in. Centering Disk, PTFE, Rigid Single	2.7 in. (68 mm)
03300-1655-0008	Kit, 4-in. Centering Disk, PTFE, Rigid Single	3.6 in. (92 mm)
03300-1655-0009	Kit, 6-in. Centering Disk, PTFE, Rigid Single	5.55 in. (141 mm)
03300-1655-0010	Kit, 8-in. Centering Disk, PTFE, Rigid Single	7.40 in. (188 mm)
03300-1655-1001	Kit, 2-in. Centering Disk, SST, Single / Twin Flex Lead	1.8 in. (45 mm)
03300-1655-1002	Kit, 3-in. Centering Disk, SST, Single / Twin Flex Lead	2.7 in. (68 mm)
03300-1655-1003	Kit, 4-in. Centering Disk, SST, Single / Twin Flex Lead	3.6 in. (92 mm)
03300-1655-1004	Kit, 6-in. Centering Disk, SST, Single / Twin Flex Lead	5.55 in. (141 mm)
03300-1655-1005	Kit, 8-in. Centering Disk, SST, Single / Twin Flex Lead	7.40 in. (188 mm)
03300-1655-1006	Kit, 2-in. Centering Disk, PTFE, Single / Twin Flex Lead	1.8 in. (45 mm)
03300-1655-1007	Kit, 3-in. Centering Disk, PTFE, Single / Twin Flex Lead	2.7 in. (68 mm)
03300-1655-1008	Kit, 4-in. Centering Disk, PTFE, Single / Twin Flex Lead	3.6 in. (92 mm)
03300-1655-1009	Kit, 6-in. Centering Disk, PTFE, Single / Twin Flex Lead	5.55 in. (141 mm)
03300-1655-1010	Kit, 8-in. Centering Disk, PTFE, Single / Twin Flex Lead	7.40 in. (188 mm)
Vented Flanges⁽²⁾		
03300-1811-9001	Fisher 249B	
03300-1811-9002	Fisher 249C	
03300-1811-9003	Masoneilan	
Flushing Connection Rings		
DP0002-2111-S6	2 in. ANSI, ¼ in. NPT connection	
DP0002-3111-S6	3 in. ANSI, ¼ in. NPT connection	
DP0002-4111-S6	4 in. ANSI, ¼ in. NPT connection	
DP0002-5111-S6	DN50, ¼ in. NPT connection	
DP0002-8111-S6	DN80, ¼ in. NPT connection	
Other		
03300-7004-0001	Viatic HART [®] Modem and cables (RS232 connection)	
03300-7004-0002	Viatic HART [®] Modem and cables (USB connection)	

(1) If a centering disc is required for a flanged probe the centering disc can be ordered with options Sx or Px on page 35 in the model code. If a centering disc is required for a threaded connection or as a spare part it should be ordered using the item numbers listed below.

(2) 1½ in. NPT threaded connection (RA) is required.

Rosemount 5300 Series

Product Data Sheet
00813-0100-4530, Rev AA
Catalog 2008 - 2009

Product Data Sheet

00813-0100-4530, Rev AA
Catalog 2008 - 2009

Rosemount 5300 Series

Standard Terms and Conditions of Sale can be found at www.rosemount.com/terms_of_sale
Rosemount and the Rosemount logotype are registered trademarks of Rosemount Inc.
PlantWeb is a registered trademark of one of the Emerson Process Management group of companies.
HART is a registered trademark of the HART Communication Foundation
Viton, and Kalrez are registered trademarks of Du Pont Performance Elastomers.
FOUNDATION is a trademark of the Fieldbus Foundation.
AMS Suite is a trademark of Emerson Process Management.
DeltaV is a trademark of Emerson Process Management group of companies.
Hastelloy is a registered trademark of Haynes International.
Monel is a registered trademark of International Nickel Co.
Eurofast and Minifast are registered trademarks of Turck Inc.
All other marks are the property of their respective owners.

Emerson Process Management, Rosemount Inc.

The Americas

Emerson Process Management
8200 Market Boulevard
Chanhassen, MN 55317 USA
T (U.S.) 1-800-999-9307
T (International) (952) 906-8888
F (952) 949-7001

Europe, Middle East & Africa

Emerson Process Management
Shared Services Ltd.
Heath Place
Bognor Regis
West Sussex PO22 9SH
England
Tel 44 1243 845500
Fax 44 1243 867554

Asia Pacific

Emerson Process Management
Singapore Pte Ltd.
1 Pandan Crescent
Singapore 128461
Tel 65 6777 8211
Fax 65 6777 0947
Enquiries@AP.emersonprocess.com

www.rosemount.com