

# Rosemount Compact Orifice Flowmeter Series

**INTEGRATED DESIGN FOR LIMITED  
STRAIGHT PIPE RUN, CLOSED LOOP  
CONTROL, AND GENERAL PURPOSE  
MONITORING APPLICATIONS**

- *Reduced installation cost compared to a traditional orifice plate*
- *Accurate and repeatable*
- *Easy-to-install direct mount assembly*
- *Self-centering*
- *Based on ASME/ISO corner tap design*
- *Patent-pending technology*

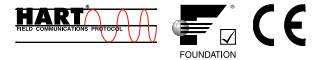

## Content

The Rosemount 405 Compact Orifice Series . . . . .	page 2
Rosemount DP Flow Solutions . . . . .	page 2
Rosemount 3051SFC Compact Orifice Flowmeter . . . . .	page 4
Specifications . . . . .	page 4
Product Certifications . . . . .	page 10
Dimensional Drawings . . . . .	page 13
Ordering Information . . . . .	page 14
Rosemount 3095MFC Compact Orifice Mass Flowmeter . . . . .	page 18
Specifications . . . . .	page 18
Product Certifications . . . . .	page 23
Dimensional Drawings . . . . .	page 25
Ordering Information . . . . .	page 26
Rosemount 405 Compact Orifice Primary Element . . . . .	page 29
Specifications . . . . .	page 29
Dimensional Drawings . . . . .	page 32
Ordering Information . . . . .	page 34
HART Configuration Data Sheet (CDS) . . . . .	page 36
FOUNDATION fieldbus™ Configuration Data Sheet (CDS) . . . . .	page 39
Fluid Data Sheet (FDS) . . . . .	page 42

## The Rosemount 405 Compact Orifice Series

### Best-in-Class Integrated DP Flowmeters

By integrating Rosemount pressure transmitters with the 405 Compact Orifice Series primary element, Rosemount provides the highest performing DP Flowmeters. This fully integrated flowmeter eliminates the need for fittings, tubing, valves, adapters, manifolds, and mounting brackets, thereby reducing welding and installation time.

### Less Expensive than an Orifice Plate Installation

Direct mounting minimizes total installed cost by reducing engineering, procurement, labor, and material expenditures while offering unsurpassed utility.

### Direct Mount

A 3-valve isolation manifold and 1-in (25 mm) thick wafer-style body allows direct mounting while eliminating field connections between the process and the differential pressure-measuring device. The integral configuration results in a robust, inexpensive, and easy-to-install assembly.

### Accurate and Repeatable

The 405C Conditioning Orifice is ideal for limited pipe run measurements in gas, liquid, or steam applications (8-in. (200 mm) nominal diameter and smaller lines). The 405C Conditioning Orifice delivers consistent and accurate measurements one would expect from traditional orifice plate technology.

### Centering Mechanism

Improper centering of any orifice type device can cause an error of up to  $\pm 5\%$  in small line sizes. A centering mechanism independent of flange rating is standard with the 405 Compact Orifice Series.

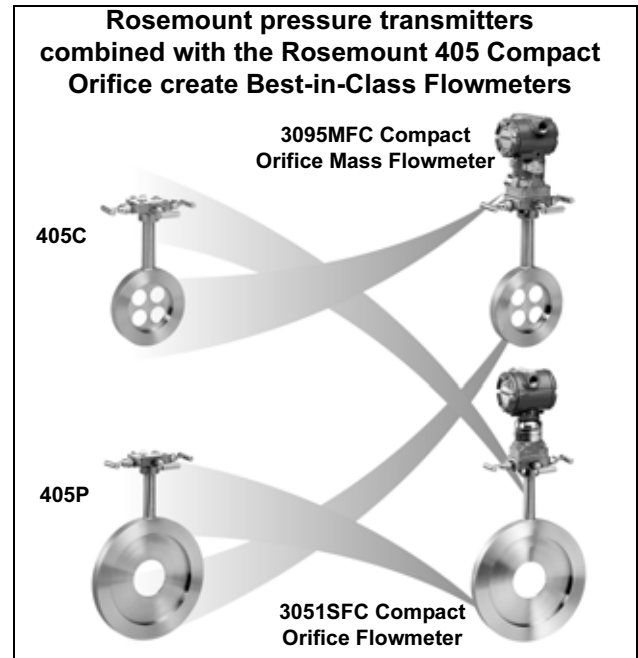

### Based on ASME/ISO Corner Tap Design

The incorporation of design features from proven standards results in a product that performs in a predictable manner and operates on well-known principles.

### Advanced PlantWeb® Functionality

Rosemount orifice flowmeters power *PlantWeb* through a scalable architecture, advanced diagnostics, and MultiVariable capabilities. This reduces operational and maintenance expenditures while improving throughput and utilities management.



## Rosemount DP Flow Solutions

### Annubar® Flowmeter Series: Rosemount 3051SFA ProBar®, 3095MFA Mass ProBar®, 485, and 285

The state-of-the-art, fifth generation Rosemount 485 Annubar combined with the 3051S or 3095 MultiVariable transmitter creates an accurate, repeatable and dependable insertion-type flowmeter. The Rosemount 285 provides a commercial product offering for your general purpose applications.

### Compact Orifice Flowmeter Series: Rosemount 3051SFC, 3095MFC, and 405

Compact Orifice Flowmeters can be installed between existing flanges, up to a Class 600 (PN100) rating. In tight fit applications, a conditioning orifice plate version is available, requiring only two diameters of straight run upstream.

### Integral Orifice Flowmeter Series: Rosemount 3051SFP ProPlate®, 3095MFP Mass ProPlate®, and 1195

These integral orifice flowmeters eliminate the inaccuracies that become more pronounced in small orifice line installations. The completely assembled, ready to install flowmeters reduce cost and simplify installation.

### Orifice Plate Primary Element Systems: Rosemount 1495 and 1595 Orifice Plates, 1496 Flange Unions and 1497 Meter Sections

A comprehensive offering of orifice plates, flange unions and meter sections that is easy to specify and order. The 1595 Conditioning Orifice provides superior performance in tight fit applications.

## 405 Compact Orifice Series Selection Guide

### Rosemount 3051SFC Compact Orifice Flowmeter

See ordering information on page 14.

- Combines the Rosemount 3051S scalable pressure transmitter with the 405 Compact Orifice Primary
- Accuracy up to  $\pm 0.80\%$  of volumetric rate
- Remote display and interface assembly enables direct mounting with "at-grade" operator interface
- *FOUNDATION*<sup>®</sup> fieldbus protocol available
- Ideal fluid type: liquid



3051SFC Compact Orifice Flowmeter

### Rosemount 3095MFC Compact Orifice Mass Flowmeter

See ordering information on page 26.

- Combines the Rosemount 3095MV MultiVariable mass flow transmitter with the 405 Compact Orifice Primary
- Accuracy up to  $\pm 0.70\%$  of mass flow rate
- Measures differential pressure, static pressure, and process temperature (remotely) all in one flowmeter assembly
- Dynamically calculates compensated mass flow
- Ideal fluid types: gas and steam



3095MFC Compact Orifice Mass Flowmeter

### Rosemount 405 Compact Orifice Primary

See ordering information on page 34.

- Integral manifold head allows direct mounting of DP transmitters
- Ideal fluid types: liquid, gas, and steam
- Accuracy up to  $\pm 0.5\%$  of discharge coefficient uncertainty
- Direct mounting capability to ANSI 600# rating
- Self-centering alignment ring



405C Conditioning Orifice

405P Compact Orifice

## Rosemount 3051SFC Compact Orifice Flowmeter

### SPECIFICATIONS

#### Performance

##### System Reference Accuracy

Percent (%) of volumetric flow rate

TABLE 1. 3051SFC Compact Orifice Flowmeter

Type	Beta	Classic (8:1 flow turndown)	Ultra (8:1 flow turndown)	Ultra for Flow (10:1 flow turndown)
3051SFCC	0.4 0.65	±1.05% ±1.20%	±0.85% ±1.00%	±0.80% ±0.90%
3051SFCCP <sup>(1)</sup>	0.4 0.65 <sup>(4)</sup>	±2.00%	±1.90%	±1.85%
3051SFCCP <sup>(2)</sup>	0.4 0.65 <sup>(4)</sup>	±2.00%	±1.90%	±1.85%
3051SFCCP <sup>(3)</sup>	0.4 0.65 <sup>(4)</sup>	±1.55%	±1.45%	±1.40%

(1) Line sizes <sup>1</sup>/<sub>2</sub>-in. (15mm)

(2) Line sizes 1-in. to 1 <sup>1</sup>/<sub>2</sub>-in. (25mm to 40mm)

(3) Line sizes 2-in. to 8-in. (50mm to 200mm)

(4) For 0.65 beta and ReD < 10,000 add an additional 0.5% to the Discharge Coefficient Uncertainty.

#### Repeatability

±0.1%

#### Line Sizes

- <sup>1</sup>/<sub>2</sub>-in. (15 mm) – not available for the 3051SFCC
- 1-in. (25 mm) – not available for the 3051SFCC
- 1 <sup>1</sup>/<sub>2</sub>-in. (40 mm) – not available for the 3051SFCC
- 2-in. (50 mm)
- 3-in. (80 mm)
- 4-in. (100 mm)
- 6-in. (150 mm)
- 8-in. (200 mm)

#### Performance Statement Assumptions

- Measured pipe I.D

#### Sizing

Contact an Emerson Process Management representative for assistance. A Configuration Data Sheet is required prior to order for application verification.

#### Functional

##### Service

- Liquid
- Gas
- Steam

##### 4–20 mA/HART

##### Zero and Span Adjustment

Zero and span values can be set anywhere within the range. Span must be greater than or equal to the minimum span.

##### Output

Two-wire 4–20 mA is user-selectable for linear or square root output. Digital process variable superimposed on 4–20 mA signal, available to any host that conforms to the HART protocol.

##### Power Supply

External power supply required.

Standard transmitter (4–20 mA): 10.5 to 42.4 V dc with no load

3051S SIS Safety transmitter: 12 to 42 Vdc with no load

3051S HART Diagnostics transmitter: 12 to 42 Vdc with no load

**Load Limitations**

Maximum loop resistance is determined by the voltage level of the external power supply, as described by:

**Standard Transmitter**

Maximum Loop Resistance =  $43.5 * (\text{Power Supply Voltage} - 10.5)$

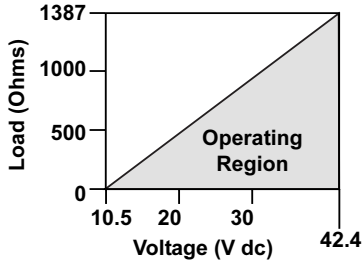

*The HART communicator requires a minimum loop resistance of 250Ω for communication.*

**3051S SIS Safety Transmitter (output code B)  
 3051S HART Diagnostics Transmitter (option code DA1)**

Maximum Loop Resistance =  $43.5 * (\text{Power Supply Voltage} - 12.0)$

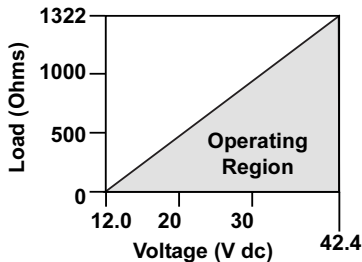

*The HART communicator requires a minimum loop resistance of 250Ω for communication.*

**HART Diagnostics Suite (Option Code DA1)**

The 3051S HART Diagnostics Transmitter provides Abnormal Situation Prevention (ASP) indication, device operating hours, variable logging, and enhanced EDDL graphic displays for easy visual analysis.

The integral statistical process monitoring (SPM) technology calculates the mean and standard deviation of the process variable 22 times per second and makes them available to the user. The 3051S ASP algorithm uses these values and highly flexible configuration options for customization to detect many user-defined or application specific abnormal situations (e.g. plugged impulse line detection).

The device operating hours are logged along with the occurrence of diagnostic events to enable quick troubleshooting of application and installation issues.

**FOUNDATION fieldbus**

**Power Supply**

External power supply required; transmitters operate on 9.0 to 32.0 V dc transmitter terminal voltage.

**Current Draw**

17.5 mA for all configurations (including LCD display option)

**FOUNDATION fieldbus Parameters**

Schedule Entries	14 (max.)
Links	30 (max.)
Virtual Communications Relationships (VCR)	20 (max.)

**Standard Function Blocks**

**Resource Block**

- Contains hardware, electronics, and diagnostic information.

**Transducer Block**

- Contains actual sensor measurement data including the sensor diagnostics and the ability to trim the pressure sensor or recall factory defaults.

**LCD Block**

- Configures the local display.

**2 Analog Input Blocks**

- Processes the measurements for input into other function blocks. The output value is in engineering or custom units and contains a status indicating measurement quality.

**PID Block with Auto-tune**

- Contains all logic to perform PID control in the field including cascade and feedforward. Auto-tune capability allows for superior tuning for optimized control performance.

**Backup Link Active Scheduler (LAS)**

The transmitter can function as a Link Active Scheduler if the current link master device fails or is removed from the segment.

**Software Upgrade in the Field**

Software for the 3051S with FOUNDATION fieldbus is easy to upgrade in the field using the FOUNDATION fieldbus Common Device Software Download procedure.

**PlantWeb Alerts**

Enable the full power of the PlantWeb digital architecture by diagnosing instrumentation issues, communicating advisory, maintenance, and failure details, and recommending a solution.

**Advanced Control Function Block Suite (Option Code A01)**

**Input Selector Block**

- Selects between inputs and generates an output using specific selection strategies such as minimum, maximum, midpoint, average, or first "good."

**Arithmetic Block**

- Provides pre-defined application-based equations including flow with partial density compensation, electronic remote seals, hydrostatic tank gauging, ratio control and others.

**Signal Characterizer Block**

- Characterizes or approximates any function that defines an input/output relationship by configuring up to twenty X, Y coordinates. The block interpolates an output value for a given input value using the curve defined by the configured coordinates.

**Integrator Block**

- Compares the integrated or accumulated value from one or two variables to pre-trip and trip limits and generates discrete output signals when the limits are reached. This block is useful for calculating total flow, total mass, or volume over time.

### Output Splitter Block

- Splits the output of one PID or other control block so that the PID will control two valves or other actuators.

### Control Selector Block

- Selects one of up to three inputs (highest, middle, or lowest) that are normally connected to the outputs of PID or other control function blocks.

Block	Execution Time
Resource	-
Transducer	-
LCD Block	-
Analog Input 1, 2	20 milliseconds
PID with Auto-tune	25 milliseconds
Input Selector	20 milliseconds
Arithmetic	20 milliseconds
Signal Characterizer	20 milliseconds
Integrator	20 milliseconds
Output Splitter	20 milliseconds
Control Selector	20 milliseconds

### Fully Compensated Mass Flow Block (Option Code H01)

Calculates fully compensated mass flow based on differential pressure with external process pressure and temperature measurements over the fieldbus segment. Configuration for the mass flow calculation is easily accomplished using the Rosemount 3095 Engineering Assistant.

### FOUNDATION fieldbus Diagnostics Suite (Option Code D01)

3051S FOUNDATION fieldbus Diagnostics provide Abnormal Situation Prevention (ASP) indication and enhanced EDDL graphic displays for easy visual analysis.

The integral statistical process monitoring (SPM) technology calculates the mean and standard deviation of the process variable 22 times per second and makes them available to the user. The 3051S ASP algorithm uses these values and highly flexible configuration options for customization to detect many user-defined or application specific abnormal situations (e.g. plugged impulse line detection).

### Process Temperature Limits

Direct Mount Electronics

- 450 °F (232 °C)

Remote Mount Electronics

- 850 °F (454 °C) – Stainless Steel

### Electronics Temperature Limits

Ambient

- -40 to 185 °F (-40 to 85 °C)
- With Integral Mount LCD Display: -4 to 175 °F (-20 to 80 °C)

Storage

- -50 to 230 °F (-46 to 110 °C)
- With Integral Mount LCD Display: -40 to 185 °F (-40 to 85 °C)

### Pressure Limits<sup>(1)</sup>

Direct Mount Electronics

- Pressure retention per ANSI B16.5 600# or DIN PN

### Static Pressure Limits

- Range 1A: Operates within specification between static line pressures of 0.5 psia to 2000 psig (0.03 to 138 bar)
- Ranges 2A– 3A: Operates within specifications between static line pressures of 0.5 psia and 3626 psig (0.03 bar-A to 250 bar-G)

### Burst Pressure Limits

Coplanar or traditional process flange

- 10000 psig (689,5 bar).

### Overpressure Limits

Flowmeters withstand the following limits without damage:

- Range 1A: 2000 psig (138 bar)
- Ranges 2A–3A: 3626 psig (250 bar)

TABLE 2. Overpressure Limits<sup>(1)</sup>

Standard	Type	Carbon Steel Rating	Stainless Steel Rating
ANSI/ASME	Class 150	285 (20)	275 (19)
ANSI/ASME	Class 300	740 (51)	720 (50)
ANSI/ASME	Class 600	1480 (102)	1440 (99)
<i>At 100 °F (38 °C), the rating decreases with increasing temperature.</i>			
DIN	PN 10/40	580 (40)	580 (40)
DIN	PN 10/16	232 (16)	232 (16)
DIN	PN 25/40	580 (40)	580 (40)
<i>At 248 °F (120 °C), the rating decreases with increasing temperature.</i>			

(1) Carbon Steel and Stainless Steel Ratings are measured in psig (bar).

(1) Static pressure selection may effect pressure limitations.

**Humidity Limits**

- 0–100% relative humidity

**Turn-On Time**

Performance within specifications less than 2 seconds (typical) after power is applied to the transmitter

**Damping**

Analog output response to a step input change is user-selectable from 0 to 60 seconds for one time constant. This software damping is in addition to sensor module response time

**Failure Mode Alarm**

**HART 4-20mA (output option codes A and B)**

If self-diagnostics detect a gross transmitter failure, the analog signal will be driven offscale to alert the user. Rosemount standard (default), NAMUR, and custom alarm levels are available (see Table 3).

High or low alarm signal is software-selectable or hardware-selectable via the optional switch (option D1).

TABLE 3. Alarm Configuration

	High Alarm	Low Alarm
Default	≥ 21.75 mA	≤ 3.75 mA
NAMUR compliant <sup>(1)</sup>	≥ 22.5 mA	≤ 3.6 mA
Custom levels <sup>(2) (3)</sup>	20.2 - 23.0 mA	3.6 - 3.8 mA

(1) Analog output levels are compliant with NAMUR recommendation NE 43, see option codes C4 or C5.

(2) Low alarm must be 0.1 mA less than low saturation and high alarm must be 0.1 mA greater than high saturation.

(3) Not available with the 3051S SIS Safety Transmitter.

**3051S SIS Safety Transmitter Failure Values**

Safety accuracy: 2.0%<sup>(1)</sup>

Safety response time: 1.5 seconds

(1) A 2% variation of the transmitter mA output is allowed before a safety trip. Trip values in the DCS or safety logic solver should be derated by 2%.

**Dynamic Performance**

	4 - 20 mA (HART®) <sup>(1)</sup>	Fieldbus protocol <sup>(2)</sup>	Typical Transmitter Response Time
<b>Total Response Time (Td + Tc)<sup>(3)</sup>:</b>			
3051S_C, Ranges 2A - 3A:	100 milliseconds	152 milliseconds	
Range 1A:	255 milliseconds	307 milliseconds	
<b>Process Variable Response Time</b>			
3051S SIS, Ranges 2A - 3A:	220 milliseconds	Not Applicable	
Range 1A:	375 milliseconds	Not Applicable	
<b>Dead Time (Td)<sup>(4)</sup></b>			
	45 milliseconds (nominal)	97 milliseconds	
<b>Update Rate</b>			
3051S	22 times per second	22 times per second	
3051S SIS	11 times per second	Not Applicable	

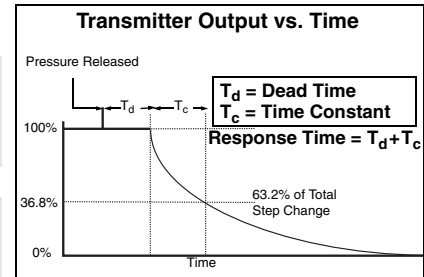

(1) Dead time and update rate apply to all models and ranges; analog output only

(2) Transmitter fieldbus output only, segment macro-cycle not included.

(3) Nominal total response time at 75 °F (24 °C) reference conditions. For option code DA1, add 40 milliseconds (nominal) to 4-20 mA (HART®) total response time values.

(4) For option code DA1, dead time (Td) is 85 milliseconds (nominal).

## Physical

### Temperature Measurement

#### Remote RTD

- 100 Ohm platinum with 1/2-in. NPT nipple and union (078 series with Rosemount 644 housing)  
Model 0078D21N00A025T32Ex  
Connection Head: 00644-4410-0011
- Standard RTD cable is shielded armored cable, length is 12 feet (3.66 m)

#### Thermowell with Remote RTD

- 1/2-in. x 1/2-in. NPT, 316 SST

### NOTE

Remote temperature measurement is not available for 1/2-in., 1-in., and 1 1/2-in. sizes.

### Electronic Connections for Remote Mount

1/2–14 NPT, G 1/2, and M20 x 1.5 (CM20) conduit. HART interface connections fixed to terminal block for output code A

### Material of Construction

#### Body/Plate

- 316 SST

#### Manifold Head/Valves

- 316 SST

#### Flange Studs and Nuts

- Customer supplied
- Available as a spare part

#### Transmitter Connection Studs and Nuts

- Studs– A193 Grade B8M.
- Nuts– A194 Grade 8M.

#### Gasket and O-rings

- Gaskets are customer supplied.
- Durlon 8500 fiber gaskets are recommended. Consult an Emerson Process Management representative for use with other gaskets.
- Available as a spare part

### NOTE

Gaskets and O-rings must be replaced when the 405 is disassembled.

### Transmitter Connections

#### Remote Mount

- Available with 1/4-in. (standard) or 1/2-in. (option code E) connections

#### Orifice Type

- Square edged
- Corner tapped
- Concentric
- Wafer-style

### Process Connections

Mounts between the following flange configurations:

ASME B16.5 (ANSI)	DIN	JIS
Class 150	PN16 (option code G)	10k (option code B)
Class 300	PN40 (option code H)	20k (option code R)
Class 600	PN100 (option code H)	40k (option code S)

ANSI alignment ring is included as standard when ordering.

### Typical Orifice Hole Sizes (For 3051SFCC)

Beta is calculated by:  $(\beta) = d_C / \text{Pipe ID}$ , where the calculated bore is equal to 2 x typical orifice hole size ( $d_C = 2d$ ). The table below shows the diameter of each of the four typical orifice holes.

TABLE 4.  $\beta = 0.4$  <sup>(1)(2)</sup>

Line Size	3051SFCC	3051SFCP
1/2-in. (15 mm)	Not Available	0.249 (6.325)
1-in. (25 mm)	Not Available	0.420 (10.668)
1 1/2-in. (40 mm)	Not Available	0.644 (16.358)
2-in. (50 mm)	0.413 (10.490)	0.827 (21.006)
3-in. (80 mm)	0.614 (15.596)	1.227 (31.166)
4-in. (100 mm)	0.805 (20.447)	1.610 (40.894)
6-in. (150 mm)	1.213 (30.810)	2.426 (61.620)
8-in. (200 mm)	1.596 (40.538)	3.192 (81.077)

TABLE 5.  $\beta = 0.65$  <sup>(1)(2)</sup>

Line Size	3051SFCC	3051SFCP
1/2-in. (15 mm)	Not Available	0.404 (10.262)
1-in. (25 mm)	Not Available	0.682 (17.323)
1 1/2-in. (40 mm)	Not Available	1.047 (26.594)
2-in. (50 mm)	0.620 (15.748) <sup>(3)</sup>	1.344 (34.138)
3-in. (80 mm)	0.997 (25.324)	1.994 (50.648)
4-in. (100 mm)	1.308 (33.223)	2.617 (66.472)
6-in. (150 mm)	1.971 (50.063)	3.942 (100.127)
8-in. (200 mm)	2.594 (65.888)	5.188 (131.775)

(1) Measurement is in inches (millimeters)

(2) Tolerance =  $\pm 0.002$ -in.

(3) Beta ( $\beta$ ) = 0.60-in. (15.24 mm) for 2-in. line size only.

### Weight

Line Size	Direct Mount (D3) <sup>(1)</sup>	Remote Mount (R3) <sup>(1)</sup>
1/2-in. (15 mm)	11.20 (5.08)	8.0 (3.63)
1-in. (25 mm)	11.70 (5.31)	8.5 (3.86)
1 1/2-in. (40 mm)	12.45 (5.65)	9.25 (4.20)
2-in. (50 mm)	13.20 (5.99)	10.0 (4.54)
3-in. (80 mm)	13.95 (6.32)	11.75 (5.33)
4-in. (100 mm)	14.95 (6.78)	13.5 (6.12)
6-in. (150 mm)	20.45 (9.28)	17.25 (7.83)
8-in. (200 mm)	24.95 (11.32)	21.75 (9.87)

(1) Measurement in lb (kg).



## Installation Considerations

### Straight Run Requirements

TABLE 6. 3051SFCC Straight Pipe Requirements<sup>(1)</sup>

	Beta	0.40	0.65	
		<b>Upstream (inlet) side of primary</b>	Reducer (1 line size)	2
		Single 90° bend or tee	2	2
		Two or more 90° bends in the same plane	2	2
		Two or more 90° bends in different plane	2	2
		Up to 10° of swirl	2	2
		Butterfly valve (75% open)	2	2
<b>Downstream (outlet) side of primary</b>		2	2	

TABLE 7. 3051SFCP Straight Pipe Requirements<sup>(1)(2)(3)</sup>

	Beta	0.40	0.65	
		<b>Upstream (inlet) side of primary</b>	Reducer (1 line size)	5
		Single 90° bend or tee	16	44
		Two or more 90° bends in the same plane	10	44
		Two or more 90° bends in different plane	50	60
		Expander	12	28
		Ball / Gate valve fully open	12	18
<b>Downstream (outlet) side of primary</b>		6	7	

- (1) Consult an Emerson Process Management representative if disturbance is not listed.
- (2) Recommended lengths represented in pipe diameters per ISO 5167.
- (3) Refer to ISO 5167 for recommended lengths when using flow straighteners.

### Pipe Orientation

Pipe orientation for both 3051SFCC Compact Conditioning and standard 3051SFCP Compact Orifice.

Orientation/ Flow Direction	Process <sup>(1)</sup>		
	Gas	Liquid	Steam
Horizontal	D/R	D/R	D/R
Vertical Up	R	D/R	R
Vertical Down	D/R	NR	NR

- (1) D = Direct mount acceptable (recommended)  
R = Remote mount acceptable  
NR = Not recommended

### Pipe Centering

Improper centering of any orifice type device can cause an error of up to ±5% in small line sizes. A centering mechanism (centering ring) independent of flange rating comes standard with the 405 Compact Orifice Series.

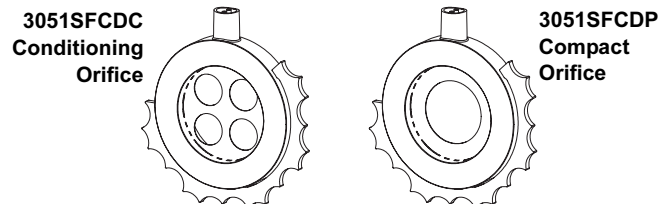

### Flowmeter Orientation

Flowmeter orientation for both 3051SFC Conditioning Compact Orifice and standard Compact Orifice.

#### Gas (Horizontal)

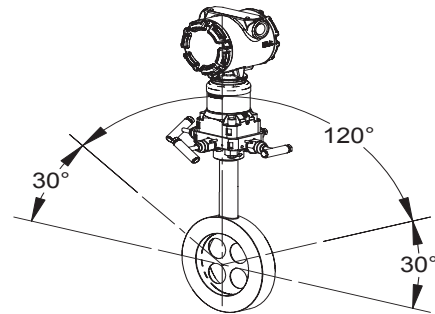

#### Liquid and Steam (Horizontal)

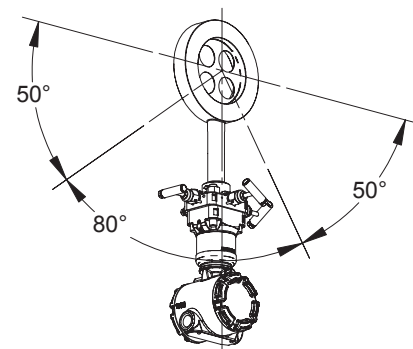

#### Gas (Vertical)

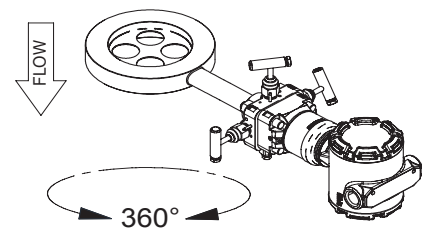

#### Liquid (Vertical)

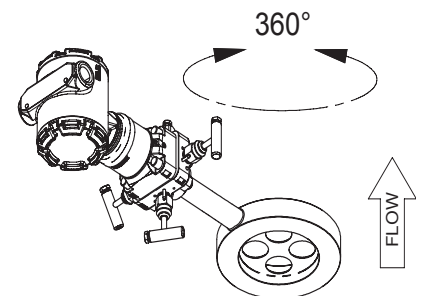

## PRODUCT CERTIFICATIONS

### Approved Manufacturing Locations

Rosemount Inc. — Chanhassen, Minnesota USA  
Emerson Process Management GmbH & Co. — Wessling, Germany  
Emerson Process Management Asia Pacific Private Limited — Singapore  
Beijing Rosemount Far East Instrument Co., LTD — Beijing, China

### European Directive Information

The EC declaration of conformity for all applicable European directives for this product can be found at [www.rosemount.com](http://www.rosemount.com). A hard copy may be obtained by contacting an Emerson Process Management representative.

#### ATEX Directive (94/9/EC)

Emerson Process Management complies with the ATEX Directive.

#### European Pressure Equipment Directive (PED) (97/23/EC)

Models 3051S\_CA4; 3051S\_CD2, 3, 4, 5; (also with P9 option)  
Pressure Transmitters — QS Certificate of Assessment - EC No. PED-H-20, Module H Conformity Assessment  
All other Model 3051S Pressure Transmitters — Sound Engineering Practice  
Transmitter Attachments: Diaphragm Seal - Process Flange - Manifold — Sound Engineering Practice  
Primary Elements, Flowmeter  
— See appropriate Primary Element QIG

#### Electro Magnetic Compatibility (EMC) (89/336/EEC)

All Models: EN 50081-1: 1992; EN 50082-2:1995;  
EN 61326-1:1997 – Industrial

### Ordinary Location Certification for FM

As standard, the transmitter has been examined and tested to determine that the design meets basic electrical, mechanical, and fire protection requirements by FM, a nationally recognized testing laboratory (NRTL) as accredited by the Federal Occupational Safety and Health Administration (OSHA).

## Hazardous Locations Certifications

### North American Certifications

#### FM Approvals

**E5** Explosion-proof for Class I, Division 1, Groups B, C, and D; dust-ignition proof for Class II and Class III, Division 1, Groups E, F, and G; hazardous locations; enclosure Type 4X, conduit seal not required when installed according to Rosemount drawing 03151-1003.

**I5/IE** Intrinsically Safe for use in Class I, Division 1, Groups A, B, C, and D; Class II, Division 1, Groups E, F, and G; Class III, Division 1; Class I, Zone 0 AEx ia IIC when connected in accordance with Rosemount drawing 03151-1006; Non-incendive for Class I, Division 2, Groups A, B, C, and D Enclosure Type 4X  
For entity parameters see control drawing 03151-1006.

#### Canadian Standards Association (CSA)

**E6** Explosion-proof for Class I, Division 1, Groups B, C, and D; Dust-Ignition-Proof for Class II and Class III, Division 1, Groups E, F, and G; suitable for Class I, Division 2, Groups A, B, C, and D, when installed per Rosemount drawing 03151-1013, CSA Enclosure Type 4X; conduit seal not required.

**I6/IF** Intrinsically Safe for Class I, Division 1, Groups A, B, C, and D when connected in accordance with Rosemount drawings 03151-1016;  
For entity parameters see control drawing 03151-1016.

## European Certifications



**I1/IA** ATEX Intrinsic Safety  
Certificate No.: BAS01ATEX1303X  II 1G  
EEx ia IIC T5 (-60°C ≤ T<sub>a</sub> ≤ 40°C)  
T4 (-60°C ≤ T<sub>a</sub> ≤ 70°C)  
T4 (-60°C ≤ T<sub>a</sub> ≤ 40°C) (FISCO)  
**CE** 1180

TABLE 8. Input Parameters

Loop / Power	Groups
U <sub>i</sub> = 30 V	HART / FOUNDATION fieldbus/ Remote Display / SIS
U <sub>i</sub> = 17.5 V	FISCO
I <sub>i</sub> = 300 mA	HART / FOUNDATION fieldbus/ Remote Display / SIS
I <sub>i</sub> = 380 mA	FISCO
P <sub>i</sub> = 1.0 W	HART / Remote Display / SIS
P <sub>i</sub> = 1.3 W	FOUNDATION fieldbus
P <sub>i</sub> = 5.32 W	FISCO
C <sub>i</sub> = 30 nF	SuperModule™ Platform
C <sub>i</sub> = 11.4 nF	HART / SIS
C <sub>i</sub> = 0	FOUNDATION fieldbus / Remote Display / FISCO
L <sub>i</sub> = 0	HART / FOUNDATION fieldbus/ SIS / FISCO
L <sub>i</sub> = 60 μH	Remote Display

#### Special conditions for safe use (x)

- The apparatus, excluding the Types 3051 S-T and 3051 S-C (In-line and Coplanar SuperModules respectively), is not capable of withstanding the 500V test as defined in Clause 6.4.12 of EN 50020. This must be considered during installation.
- The terminal pins of the Types 3051 S-T and 3051 S-C must be protected to IP20 minimum.

**N1** ATEX Type n  
Certificate No.: BAS01ATEX3304X  II 3 G  
EEx nL IIC T5 ( $T_a = -40\text{ °C TO } 70\text{ °C}$ )  
 $U_i = 45\text{ Vdc max}$   
IP66  
**CE**

**Special conditions for safe use (x)**

The apparatus is not capable of withstanding the 500V insulation test required by Clause 9.1 of EN 50021: 1999. This must be taken into account when installing the apparatus.

**ND** ATEX Dust  
Certificate No.: BAS01ATEX1374X  II 1 D  
 $T_{105\text{ °C}} (-20\text{ °C} \leq T_{\text{amb}} \leq 85\text{ °C})$   
 $V_{\text{max}} = 42.4\text{ volts max}$   
 $A = 24\text{ mA}$   
IP66  
**CE 1180**

**Special conditions for safe use (x)**

1. The user must ensure that the maximum rated voltage and current (42.4 volts, 22 milliampere, DC) are not exceeded. All connections to other apparatus or associated apparatus shall have control over this voltage and current equivalent to a category "ib" circuit according to EN 50020.
2. Cable entries must be used which maintain the ingress protection of the enclosure to at least IP66.
3. Unused cable entries must be filled with suitable blanking plugs which maintain the ingress protection of the enclosure to at least IP66.
4. Cable entries and blanking plugs must be suitable for the ambient range of the apparatus and capable of withstanding a 7J impact test.
5. The 3051S must be securely screwed in place to maintain the ingress protection of the enclosure.

**E1** ATEX Flameproof  
Certificate No.: KEMA00ATEX2143X  II 1/2 G  
EEx d IIC T6 ( $-50\text{ °C} \leq T_{\text{amb}} \leq 65\text{ °C}$ )  
EEx d IIC T5 ( $-50\text{ °C} \leq T_{\text{amb}} \leq 80\text{ °C}$ )  
 $V_{\text{max}} = 42.4\text{V}$   
**CE 1180**

**Special conditions for safe use (x)**

This device contains a thin wall diaphragm. Installation, maintenance and use shall take into account the environmental conditions to which the diaphragm will be subjected. The manufacturer's instructions for installation and maintenance shall be followed in detail to assure safety during its expected lifetime. The Model 3051S pressure transmitter must include a Series 300S housing integrally mounted to a Series Model 3051S Sensor module as per Rosemount drawing 03151-1023.

**Japanese Certifications**

**E4** JIS Flameproof  
Ex d IIC T6

Certificate	Description
TC15682	Coplanar with Junction Box Housing
TC15683	Coplanar with PlantWeb Housing
TC15684	Coplanar with PlantWeb Housing and LCD Display
TC15685	In-Line SST with Junction Box Housing
TC15686	In-Line Hastelloy with Junction Box Housing
TC15687	In-Line SST with PlantWeb Housing
TC15688	In-Line Hastelloy with Plantweb Housing
TC15689	In-Line SST with Plantweb Housing and LCD Display
TC15690	In-Line Hastelloy with PlantWeb Housing and LCD Display

**Australian Certifications**

**E7** SAA Explosion-proof and DIP  
Certification No.: AUS Ex 3798X  
Ex d IIC T6 ( $T_a = 60\text{ °C}$ ) IP66  
DIP A21 TA T6 ( $T_a = 60\text{ °C}$ ) IP66

**Special conditions for safe use (x)**

1. It is a condition of manufacture that each transmitter module shall be pressure tested in accordance with clause 4.3 of AS 2380.2 at minimum pressure of 1450 kPa. As the model 300S housing passed tests at 4 times the reference pressures (400 kPa for single and 3800 kPa for dual compartment housing) and are not of welded construction, they may be exempted from the routing pressure test of clause 4.3 of AS 2380.2.
2. It is a condition of manufacture that each transmitter module and housing combination shall be subjected to a routine high voltage test in accordance with clause 6.2 of AS 2380.1, with the following variation. The test voltage applied to each single or dual compartment housing shall not be less than 500 V, 47 to 62 Hz, for a period of not less than one minute, with a breakdown current of less than 5 mA.
3. It is a condition of safe use that each housing shall be connected to external circuits via suitable conduit or Standards Australia certified cable glands. Where only one entry is used for connection to external circuits, the unused entry shall be closed by means of the blanking plug supplied by the equipment manufacturer or by a suitable Standards Australia certified blanking plug.
4. It is a condition of safe use that a dielectric strength test shall be applied whenever the terminal block is changed or replaced in either the dual compartment or single compartment housings. The breakdown current shall be less than 5 mA, when 500 V, 47 to 62 Hz, is applied for one minute. Note: if tested with an optional T1 transient protector terminal block fitted, the protection will operate and hence there will be no current indicated.
5. It is a condition of safe use that each transmitter module shall be used with a Model 300S housing, in order to comply with flameproof requirements.

6. It is a condition of safe use that each model 300S housing fitted with a transmitter module shall be marked with the same certification marking code information. Should the housing be replaced after initial supply to another model 300S housing, the replacement housing shall have the same certification marking code information as the housing it replaces.

## IECEX Certifications

### I7/IG IECEX Intrinsic Safety

Certificate No.: IECEXBAS04.0017X

Ex ia IIC T5 ( $T_a = -60\text{ °C}$  to  $40\text{ °C}$ ) -HART/SIS/Remote Meter

Ex ia IIC T4 ( $T_a = -60\text{ °C}$  to  $70\text{ °C}$ ) -HART/SIS/Remote Meter

Ex ia IIC T4 ( $T_a = -60\text{ °C}$  to  $70\text{ °C}$ ) -FOUNDATION Fieldbus

Ex ia IIC T4 ( $T_a = -60\text{ °C}$  to  $40\text{ °C}$ ) -FISCO

IP66

TABLE 9. Input Parameters

Loop / Power	Groups
$U_i = 30\text{ V}$	HART / FOUNDATION fieldbus/ Remote Display / SIS
$U_i = 17.5\text{ V}$	FISCO
$I_i = 300\text{ mA}$	HART / FOUNDATION fieldbus/ Remote Display / SIS
$I_i = 380\text{ mA}$	FISCO
$P_i = 1.0\text{ W}$	HART / Remote Display / SIS
$P_i = 1.3\text{ W}$	FOUNDATION fieldbus
$P_i = 5.32\text{ W}$	FISCO
$C_i = 30\text{ nF}$	SuperModule™ Platform
$C_i = 11.4\text{ nF}$	HART / SIS
$C_i = 0$	FOUNDATION fieldbus / Remote Display / FISCO
$L_i = 0$	HART / FOUNDATION fieldbus/ SIS / FISCO

### Special conditions for safe use (x)

1. The Models 3051S HART 4-20mA, 3051S Fieldbus, 3051S Profibus and 3051S FISCO are not capable of withstanding the 500V test as defined in clause 6.4.12 of IEC 60079-11. This must be taken into account during installation.

2. The terminal pins of the Types 3051S-T and 3051S-C must be protected to IP20 minimum.

### N7 IECEX Type n

Certificate No.: IECEXBAS04.0018X

Ex nC IIC T5 ( $T_a = -40\text{ °C}$  to  $70\text{ °C}$ )

$U_i = 45\text{ Vdc MAX}$

IP66

### Special conditions for safe use (x)

The apparatus is not capable of withstanding the 500 V insulation test required by Clause 8 of IEC 79-15: 1987.

## Combinations of Certifications

Stainless steel certification tag is provided when optional approval is specified. Once a device labeled with multiple approval types is installed, it should not be reinstalled using any other approval types. Permanently mark the approval label to distinguish it from unused approval types.

**K1** Combination of E1, I1, N1, and ND

**K5** Combination of E5 and I5

**K6** Combination of E6 and I6

**K7** Combination of E7, I7, and N7

**KA** Combination of E1, I1, E6, and I6

**KB** Combination of E5, I5, I6 and E6

**KC** Combination of E5, E1, I5 and I1

**KD** Combination of E5, I5, E6, I6, E1, and I1

**DIMENSIONAL DRAWINGS**

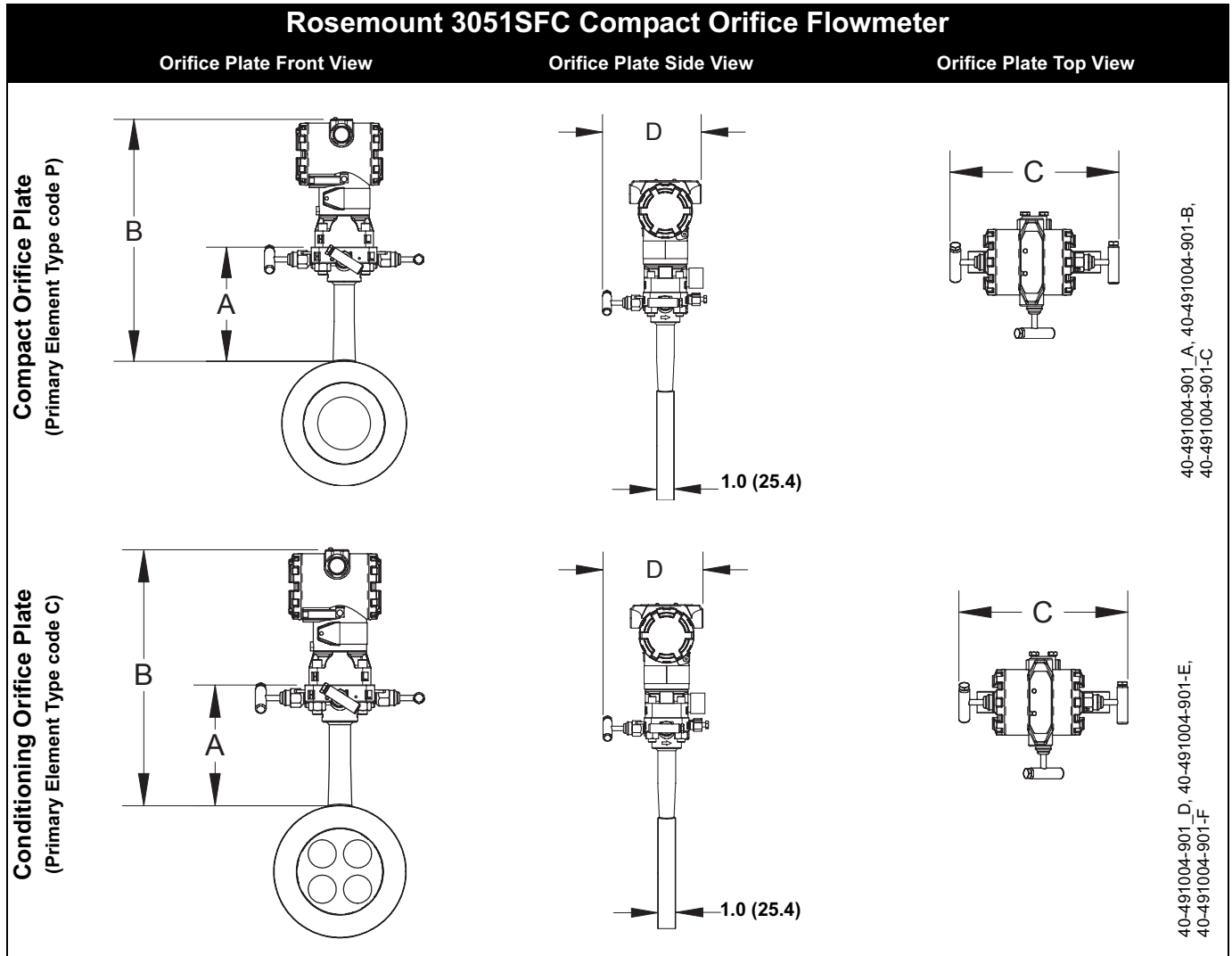

TABLE 10. Dimensional Drawings<sup>(1)</sup>

Plate Type	A	B	Transmitter Height	C	D
Type P and C	6.0 (152)	Transmitter Height + A	7.75 (197)	7.75 (197) - closed 8.25 (210) - open	6.00 (152) - closed 6.25 (159) - open

<sup>(1)</sup> Measurement in inches (millimeters).

# Rosemount Compact Orifice Flowmeter Series

**Product Data Sheet**  
00813-0100-4810, Rev FA  
August 2006

## ORDERING INFORMATION

### Rosemount 3051SFC Compact Orifice Flowmeter Ordering Information

Model	Product Description		
3051SFC	Compact Orifice Flowmeter		
Code	Measurement Type		
D	Differential Pressure		
Code	Primary Element Type		
C	Conditioning Orifice Plate		
P	Orifice Plate		
Code	Material Type		
S	316 Stainless Steel (SST)		
Code	Line Size		
005 <sup>(1)</sup>	1/2-in. (15 mm)		
010 <sup>(1)</sup>	1-in. (25 mm)		
015 <sup>(1)</sup>	1 1/2-in. (40 mm)		
020	2-in. (50 mm)		
030	3-in. (80 mm)		
040	4-in. (100 mm)		
060	6-in. (150 mm)		
080	8-in. (200 mm)		
Code	Primary Element Style		
N	Square Edged		
Code	Beta Ratio		
040	0.40 Beta Ratio ( $\beta$ )		
065 <sup>(2)</sup>	0.65 Beta Ratio ( $\beta$ )		
Code	Temperature Measurement		
R	Remote Thermowell and RTD		
0	No Temperature Sensor		
Code	Electronics Connection Platform		
3	Direct-mount, 3-valve integral manifold, SST		
7	Remote-mount, 1/4-in. NPT connections		
Code	Differential Pressure Range		
1A	0 to 25 in H <sub>2</sub> O (0 to 62.2 mbar)		
2A	0 to 250 in H <sub>2</sub> O (0 to 623 mbar)		
3A	0 to 1000 in H <sub>2</sub> O (0 to 2.5 bar)		
Code	Output Protocol		
A	4–20 mA with digital signal based on <i>HART</i> protocol		
B <sup>(3)</sup>	4–20 mA Safety Certified with digital signal based on <i>HART</i> protocol		
F <sup>(4)</sup>	<i>FOUNDATION</i> fieldbus protocol		
Code	Electronics Housing Style	Material	Conduit Entry Size
1A	<i>PlantWeb</i> Housing	Aluminum	1/2-14 NPT
1B	<i>PlantWeb</i> Housing	Aluminum	M20 x 1.5 (CM20)
1C	<i>PlantWeb</i> Housing	Aluminum	G1/2
1J	<i>PlantWeb</i> Housing	316L SST	1/2-14 NPT
1K	<i>PlantWeb</i> Housing	316L SST	M20 x 1.5 (CM20)
1L	<i>PlantWeb</i> Housing	316L SST	G1/2
2A	Junction Box Housing	Aluminum	1/2-14 NPT
2B	Junction Box Housing	Aluminum	M20 x 1.5 (CM20)
2C	Junction Box Housing	Aluminum	G1/2
2E	Junction Box housing with output for remote display and interface	Aluminum	1/2-14 NPT
2F	Junction Box housing with output for remote display and interface	Aluminum	M20 x 1.5 (CM20)
2G	Junction Box housing with output for remote display and interface	Aluminum	G1/2
2J	Junction Box Housing	316L SST	1/2-14 NPT

**Rosemount 3051SFC Compact Orifice Flowmeter Ordering Information**

2M	Junction Box housing with output for remote display and interface	316L SST	1/2-14 NPT
7J <sup>(5)</sup>	Quick Connect (A size Mini, 4-pin male termination)	316L SST	
<b>Code</b>	<b>Electronics Performance Class for Flow</b>		
3 <sup>(6)</sup>	Ultra for Flow: up to $\pm 0.75\%$ flow rate accuracy, 14:1 flow turndown, 10-year stability, limited 12-year warranty		
1 <sup>(6)</sup>	Ultra: up to $\pm 0.85\%$ flow rate accuracy, 8:1 flow turndown, 10-year stability, limited 12-year warranty		
2	Classic: up to $\pm 1.05\%$ flow rate accuracy, 8:1 flow turndown, 5-year stability		
<b>Code</b>	<b>Options</b>		
<b>Installation Accessories</b>			
G	DIN alignment ring (PN 16)		
H	DIN alignment ring (PN 40, PN 100)		
B	JIS Alignment Ring 10K		
R	JIS Alignment Ring 20K		
S	JIS Alignment Ring 40K		
<b>Remote Adapters</b>			
E	Flange adapters 316 SST (1/2-in. NPT)		
<b>High Temperature Applications</b>			
T	Graphite valve packing (Tmax = 850 °F)		
<b>Flow Calibration</b>			
WC <sup>(7)</sup>	Discharge coefficient verification (3 point)		
WD <sup>(7)</sup>	Discharge coefficient verification (full 10 point)		
<b>Pressure Testing</b>			
P1	Hydrostatic testing with certificate		
<b>Special Cleaning</b>			
P2	Cleaning for special processes		
PA	Cleaning per ASTM G93 Level D (section 11.4)		
<b>Special Inspection</b>			
QC1	Visual and dimensional inspection with certificate		
QC7	Inspection and performance certificate		
<b>Transmitter Calibration Certification</b>			
Q4	Calibration Data Certificate for Transmitter		
QP	Calibration Data Certificate and Tamper Evident Seal		
<b>Material Traceability Certification</b>			
Q8	Material certification per ISO 10474 3.1.B and EN 10204 3.1.B		
<b>Safety Certification</b>			
QS	Certificate of FMEDA data		
<b>Code Conformance</b>			
J2	ANSI B31.1		
J3	ANSI B31.3		
J4	ANSI B31.8		
J5 <sup>(8)</sup>	NACE MR-0175 / ISO 15156		
<b>Country Certification</b>			
J1	Canadian Registration		
<b>Product Certifications</b>			
E1	ATEX Flameproof		
I1	ATEX Intrinsically Safe		
N1	ATEX Type n		
IA <sup>(9)</sup>	ATEX FISCO Intrinsically Safe; for FOUNDATION fieldbus protocol only		
K1	ATEX Flameproof, Intrinsically Safe, Type n, Dust (combination of E1, I1, N1, and ND)		
ND	ATEX Dust		
E5	FM Explosion-proof		
I5	FM Intrinsically Safe, Non-incendive		
IE <sup>(9)</sup>	FM FISCO Intrinsically Safe; for FOUNDATION fieldbus protocol only		
K5	FM Explosion-proof, Intrinsically Safe, Non-incendive (combination of E5 and I5)		
E6	CSA Explosion-proof, Division 2		
I6	CSA Intrinsically Safe		
IF <sup>(9)</sup>	CSA FISCO Intrinsically Safe; for FOUNDATION fieldbus protocol only		

# Rosemount Compact Orifice Flowmeter Series

Product Data Sheet  
00813-0100-4810, Rev FA  
August 2006

## Rosemount 3051SFC Compact Orifice Flowmeter Ordering Information

K6	CSA Explosion-proof, Intrinsically Safe, Division 2 (combination of E6 and I6)
E7 <sup>(9)</sup>	SAA Flameproof, Dust Ignition-proof
I7	IECEX Intrinsically Safe
IG <sup>(9)</sup>	IECEX FISCO Intrinsically Safe
N7	IECEX Type n
K7	SAA Flameproof, Dust Ignition-proof, IECEX Intrinsically Safe, and Type n (combination of E7, I7, and N7)
KA	ATEX and CSA Flameproof, Intrinsically Safe (combination of E1, I1, E6, and I6) <i>Note: Only available on Housing Style codes 1A, 1J, 2A, 2J, 2E, or 2M.</i>
KB	FM and CSA Explosion-proof, Intrinsically Safe, Division 2 (combination of E5, E6, I5, and I6) <i>Note: Only available on Housing Style codes 1A, 1J, 2A, 2J, 2E, or 2M.</i>
KC	FM and ATEX Explosion-proof, Intrinsically Safe, Non-incendive (combination of E5, E1, I5, and I1) <i>Note: Only available on Housing Style codes 1A, 1J, 2A, 2J, 2E, or 2M.</i>
KD	FM, CSA, and ATEX Explosion-proof, Intrinsically Safe (combination of E5, I5, E6, I6, E1, and I1) <i>Note: Only available on Housing Style codes 1A, 1J, 2A, 2J, 2E, or 2M.</i>
<b>Alternative Transmitter Material of Construction</b>	
L1	Inert Sensor Fill Fluid (not available with Differential Pressure range code 1A)
L2	Graphite-filled Teflon <sup>®</sup> (PTFE) o-ring
LA	Inert sensor fill fluid and graphite-filled Teflon (PTFE) o-ring
<b>Display<sup>(10)</sup></b>	
M5	<i>PlantWeb</i> LCD display
M7 <sup>(6)(11)</sup>	Remote mount LCD display and interface, <i>PlantWeb</i> housing, no cable, SST bracket
M8 <sup>(6)(11)</sup>	Remote mount LCD display and interface, <i>PlantWeb</i> housing, 50 foot cable, SST bracket
M9 <sup>(6)(11)</sup>	Remote mount LCD display and interface, <i>PlantWeb</i> housing, 100 foot cable, SST bracket
<b>Terminal Blocks</b>	
T1 <sup>(10)</sup>	Transient terminal block
T2 <sup>(12)</sup>	Terminal block with WAGO spring clamp terminals
T3 <sup>(12)</sup>	Transient terminal block with WAGO spring clamp terminals
<b>Manifold for Remote Mount Option</b>	
F2	3-Valve Manifold, SST
F6	5-Valve Manifold, SST
<b><i>PlantWeb</i> Control Functionality</b>	
A01 <sup>(13)</sup>	FOUNDATION fieldbus Advanced Control Function Block Suite
<b><i>PlantWeb</i> Diagnostic Functionality</b>	
D01 <sup>(13)</sup>	FOUNDATION fieldbus Diagnostics Suite
DA1 <sup>(14)</sup>	HART Diagnostic Suite
<b><i>PlantWeb</i> Enhanced Measurement Functionality</b>	
H01 <sup>(13)(15)</sup>	Fully Compensated Mass Flow Block
<b>Special Configuration (Software)</b>	
C4 <sup>(16)</sup>	NAMUR alarm and saturation signal levels, high alarm
C5 <sup>(16)</sup>	NAMUR alarm and saturation signal levels, low alarm
C6 <sup>(6)(16)</sup>	Custom alarm and saturation signal levels, high alarm <i>Note: Requires option code C1, custom software configuration. A Configuration Data Sheet must be completed, see page 36.</i>
C7 <sup>(6)(16)</sup>	Custom alarm and saturation signal levels, low alarm <i>Note: Requires option code C1, custom software configuration. A Configuration Data Sheet must be completed, see page 36.</i>
C8 <sup>(16)</sup>	Low alarm (standard Rosemount alarm and saturation signal levels)
<b>Special Configuration (Hardware)</b>	
D1 <sup>(16)</sup>	Hardware Adjustment (zero, span, alarm, security).
D4	External ground screw
DA <sup>(16)</sup>	Hardware adjustment (zero, span, security) and external ground screw
<b>Conduit Electrical Connector</b>	
GE <sup>(17)</sup>	M12, 4-pin, Male Connector ( <i>euromast</i> <sup>®</sup> )
GM <sup>(17)</sup>	A size Mini, 4-pin, Male Connector ( <i>minifast</i> <sup>®</sup> )



- (1) *Not available for Primary Element Type code C.*
- (2) *For 2-in. (50.8 mm) line sizes the Beta Ratio is 0.6 for Primary Element Type code C.*
- (3) *Requires PlantWeb housing and Hardware Adjustments option code D1.*
- (4) *Requires PlantWeb housing.*
- (5) *Available with output code A only. Available approvals are FM Intrinsically Safe, Non-incendive (option code I5) or ATEX Intrinsically Safe (option code I1). Contact an Emerson Process Management representative for additional information.*
- (6) *Not available with Output Protocol code B.*
- (7) *Not available with Primary Element Type code P.*
- (8) *Materials of Construction comply with metallurgical requirements within NACE MR0175/ISO for sour oil field production environments. Environmental limits apply to certain materials. Consult latest standard for details. Selected materials also conform to NACE MR0103 for sour refining environments.*
- (9) *Consult factory for availability.*
- (10) *Not available with Housing code 7J.*
- (11) *Not available with Output Protocol code F or option code DA1.*
- (12) *Available with Output Protocol code A and Plantweb housing only.*
- (13) *Requires PlantWeb housing and output code F.*
- (14) *Requires PlantWeb housing and output code A. Includes Hardware Adjustments as standard. Contact an Emerson Process Management representative regarding availability.*
- (15) *Requires Rosemount 3095 Engineering Assistant to configure.*
- (16) *Not available for Output Protocol code F.*
- (17) *Not available with Housing code 7J. Available with Intrinsically Safe approvals only. For FM Intrinsically Safe, Non-incendive approval (option code I5) or FM FISCO Intrinsically Safe approval (option code IE), install in accordance with Rosemount drawing 03151-1009 to maintain NEMA 4X rating.*

## Rosemount 3095MFC Compact Orifice Mass Flowmeter

### SPECIFICATIONS

#### Performance

##### System Reference Accuracy

Percent (%) of mass flow rate

TABLE 11. 3095MFC Compact Orifice Mass Flowmeter

TYPE	BETA	Mass flow (8:1 flow turndown)	Ultra for Flow (10:1 flow turndown)
3095MFCC	0.4	±0.90%	±0.70%
	0.65	±1.10%	±0.90%
3095MFCCP <sup>(1)</sup>	0.4	±2.50%	±2.45%
	0.65 <sup>(4)</sup>		
3095MFCCP <sup>(2)</sup>	0.4	±2.10%	±2.00%
	0.65 <sup>(4)</sup>		
3095MFCCP <sup>(3)</sup>	0.4	±1.50%	±1.40%
	0.65 <sup>(4)</sup>		

(1) Line sizes 1/2-in. (15mm)

(2) Line sizes 1-in. to 1 1/2-in. (25mm to 40mm)

(3) Line sizes 2-in. to 8-in. (50mm to 200mm)

(4) For 0.65 beta and  $ReD < 10,000$  add an additional 0.5% to the Discharge Coefficient Uncertainty.

#### Repeatability

±0.1%

#### Line Sizes

- 1/2-in. (15 mm) – not available for the 3095MFCC
- 1-in. (25 mm) – not available for the 3095MFCC
- 1 1/2-in. (40 mm) – not available for the 3095MFCC
- 2-in. (50 mm)
- 3-in. (80 mm)
- 4-in. (100 mm)
- 6-in. (150 mm)
- 8-in. (200 mm)

#### Output

Two-wire 4–20 mA, user-selectable for DP, AP, GP, PT, mass flow, or totalized flow. Digital *HART* protocol superimposed on 4–20 mA signal, available to any host that conforms to the *HART* protocol.

#### Performance Statement Assumptions

- Measured pipe I.D
- Electronics are trimmed for optimum flow accuracy

#### Sizing

Contact an Emerson Process Management representative for assistance. A Configuration Data Sheet is required prior to order for application verification.

#### Functional

##### Service

- Liquid
- Gas
- Steam

##### Power Supply

4–20 mA option

- External power supply required. Standard transmitter (4–20 mA) operates on 11 to 55 v dc with no load

##### Process Temperature Limits

Direct Mount Electronics

- 450 °F (232 °C)

Remote Mount Electronics

- 850 °F (454 °C) – Stainless Steel

##### Electronics Temperature Limits

Ambient

- -40 to 185 °F (-40 to 85 °C)
- with integral meter: -4 to 175 °F (-20 to 80 °C)

Storage

- -50 to 230 °F (-46 to 110 °C)
- with integral meter: -40 to 185 °F (-40 to 85 °C)

##### Pressure Limits<sup>(1)</sup>

Direct Mount Electronics

- Pressure retention per ANSI B16.5 600# or DIN PN 100

##### Overpressure Limits

0 to 2 times the absolute pressure range with a maximum of 3626 psia (250 bar).

##### Static Pressure Limits

Operates within specification between static pressures of 0.5 psia (0.03 bar-A) and the URL of the static pressure sensor.

(1) Static pressure selection may effect pressure limitations.

**Load Limitations**

Maximum loop resistance is determined by the voltage level of the external power supply, as described by:

$$\text{Maximum Loop Resistance} = \frac{\text{Power Supply} - 11.0}{0.022}$$

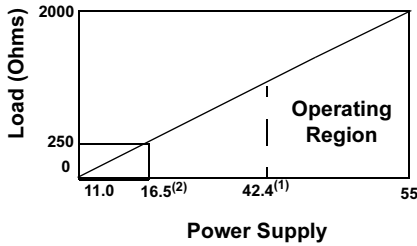

(1) For CSA approval, power supply must not exceed 42.4 V dc.

(2) HART protocol communication requires a loop resistance value between 250-1100 ohms, inclusive.

**FOUNDATION fieldbus (output option code V)**

**Power Supply**

External power supply required; transmitters operate on 9.0 to 32.0 V dc transmitter terminal voltage.

**Current Draw**

17.5 mA for all configurations (including LCD display option)

**Humidity Limits**

- 0–100% relative humidity

**Turn-On Time**

Digital and analog measured variables will be within specification 7 – 10 seconds after power is applied to the transmitter.

Digital and analog flow output will be within specifications 10 – 14 seconds after power is applied to the transmitter.

**Damping**

Analog output response to a step input change is user-selectable from 0 to 29 seconds for one time constant. This software damping is in addition to sensor module response time

**Failure Mode Alarm**

**Output Code A**

If self-diagnostics detect a non-recoverable transmitter failure, the analog signal will be driven either below 3.75 mA or above 21.75 mA to alert the user. High or low alarm signal is user-selectable by internal jumper pins.

**Output Code V**

If self-diagnostics detect a gross transmitter failure, that information gets passed as a status along with the process variable(s).

**Configuration**

HART Hand-held Communicator (Model 275 or 375)

- Performs traditional transmitter maintenance functions

3095 Multivariable Engineering Assistant (EA) software package

- Contains built-in physical property database
- Enables mass flow configuration, maintenance, and diagnostic functions via HART modem (output option code A)

Enables mass flow configuration via PCMCIA Interface for FOUNDATION fieldbus (output option code V)

**Physical Properties Database**

- Maintained in Engineering Assistant Software Configurator
- Physical properties for over 110 fluids
- Natural gas per AGA
- Steam and water per ASME
- Other database fluids per American Institute of Chemical Engineers (AIChE)
- Optional custom entry

**FOUNDATION fieldbus Function Blocks**

**Standard Function Blocks**

**Resource Block**

- Contains hardware, electronics, and diagnostic information.

**Transducer Block**

- Contains actual sensor measurement data including the sensor diagnostics and the ability to trim the pressure sensor or recall factory defaults.

**LCD Block**

- Configures the local display.

**5 Analog Input Blocks**

- Processes the measurements for input into other function blocks. The output value is in engineering or custom units and contains a status indicating measurement quality.

**PID Block with Auto-tune**

- Contains all logic to perform PID control in the field including cascade and feedforward. Auto-tune capability allows for superior tuning for optimized control performance.

**Advanced Control Function Block Suite (Option Code A01)**

**Input Selector Block**

- Selects between inputs and generates an output using specific selection strategies such as minimum, maximum, midpoint, average, or first "good."

**Arithmetic Block**

- Provides pre-defined application-based equations including flow with partial density compensation, electronic remote seals, hydrostatic tank gauging, ratio control and others.

**Signal Characterizer Block**

- Characterizes or approximates any function that defines an input/output relationship by configuring up to twenty X, Y coordinates. The block interpolates an output value for a given input value using the curve defined by the configured coordinates.

**Integrator Block**

- Compares the integrated or accumulated value from one or two variables to pre-trip and trip limits and generates discrete output signals when the limits are reached. This block is useful for calculating total flow, total mass, or volume over time.

**Output Splitter Block**

- Splits the output of one PID or other control block so that the PID will control two valves or other actuators.

**Control Selector Block**

- Selects one of up to three inputs (highest, middle, or lowest) that are normally connected to the outputs of PID or other control function blocks.

## Physical

### Temperature Measurement <sup>(1)</sup>

#### Remote RTD

- 100 Ohm platinum with 1/2-in. NPT nipple and union (078 series with Rosemount 644 housing)  
Model 0078D21N00A025T32Ex  
Connection Head: 00644-4410-0011
- Standard RTD cable is shielded armored cable, length is 12 feet (3.66 m)
- Remote RTD material is SST

#### Thermowell

- 1/2-in. x 1/2-in. NPT, 316 SST

### NOTE

Remote temperature measurement is not available for 1/2-in., 1-in., and 1 1/2-in. sizes.

### Electronic Connections for Remote Mount

- 1/2-14 NPT, G 1/2, and M20 x 1.5 (CM20) conduit. HART interface connections fixed to terminal block for output code A

## Material of Construction

#### Body/Plate

- 316 SST

#### Manifold Head/Valves

- 316 SST

#### Flange Studs and Nuts

- Customer supplied
- Available as a spare part

#### Transmitter Connection Studs and Nuts

- Studs– A193 Grade B8M.
- Nuts– A194 Grade 8M.

#### Gasket and O-rings

- Gaskets are customer supplied.
- Durlon 8500 fiber gaskets are recommended. Consult an Emerson Process Management representative for use with other gaskets.
- Available as a spare part

### NOTE

Gaskets and O-rings should be replaced when the 405 is disassembled.

## Transmitter Connections

#### Remote Mount

- Available with 1/4-in. (standard) or 1/2-in. (option code E) connections

#### Orifice Type

- Square edged
- Corner tapped
- Concentric
- Wafer-style

## Process Connections

Mounts between the following flange configurations

ASME B16.5 (ANSI)	DIN	JIS
Class 150	PN16 (option code G)	10k (option code B)
Class 300	PN40 (option code H)	20k (option code R)
Class 600	PN100 (option code H)	40k (option code S)

ANSI alignment ring is included as standard when ordering

**Typical Orifice Hole Sizes (For 3051MFCC)**

Beta is calculated by:  $(\beta) = d_C / \text{Pipe ID}$ , where the calculated bore is equal to 2 x typical orifice hole size ( $d_C = 2d$ ). The table below shows the diameter of each of the four typical orifice holes.

TABLE 12.  $\beta = 0.4^{(1)(2)}$

Line Size	3095MFCC	3095MFCP
1/2-in. (15 mm)	Not Available	0.249 (6.325)
1-in. (25 mm)	Not Available	0.420 (10.668)
1 1/2-in. (40 mm)	Not Available	0.644 (16.358)
2-in. (50 mm)	0.413 (10.490)	0.827 (21.006)
3-in. (80 mm)	0.614 (15.596)	1.227 (31.166)
4-in. (100 mm)	0.805 (20.447)	1.610 (40.894)
6-in. (150 mm)	1.213 (30.810)	2.426 (61.620)
8-in. (200 mm)	1.596 (40.538)	3.192 (81.077)

TABLE 13.  $\beta = 0.65^{(1)(2)}$

Line Size	3095MFCC	3095MFCP
1/2-in. (15 mm)	Not Available	0.404 (10.262)
1-in. (25 mm)	Not Available	0.682 (17.323)
1 1/2-in. (40 mm)	Not Available	1.047 (26.594)
2-in. (50 mm)	0.620 (15.748) <sup>(3)</sup>	1.344 (34.138)
3-in. (80 mm)	0.997 (25.324)	1.994 (50.648)
4-in. (100 mm)	1.308 (33.223)	2.617 (66.472)
6-in. (150 mm)	1.971 (50.063)	3.942 (100.127)
8-in. (200 mm)	2.594 (65.888)	5.188 (131.775)

(1) Measurement is in inches (millimeters)

(2) Tolerance =  $\pm 0.002$ -in.

(3) Beta ( $\beta$ ) = 0.60-in. (15.24 mm) for 2-in. line size only.

**Weight**

Line Size (in.)	Direct Mount (D3) <sup>(1)</sup>	Remote Mount (R3) <sup>(1)</sup>
1/2-in. (15 mm)	11.20 (5.08)	8.0 (3.63)
1-in. (25 mm)	11.70 (5.31)	8.5 (3.86)
1 1/2-in. (40 mm)	12.45 (5.65)	9.25 (4.20)
2-in. (50 mm)	13.20 (5.99)	10 (4.54)
3-in. (80 mm)	13.95 (6.32)	11.75 (5.33)
4-in. (100 mm)	14.95 (6.78)	13.5 (6.12)
6-in. (150 mm)	20.45 (9.28)	17.25 (7.83)
8-in. (200 mm)	24.95 (11.32)	21.75 (9.87)

(1) Measurement in lb (kg).

**Installation Considerations**

**Straight Run Requirements**

TABLE 14. 3095MFCC Straight Pipe Requirements<sup>(1)</sup>

Beta	0.40	0.65	
Upstream (inlet) side of primary	Reducer (1 line size)	2	2
	Single 90° bend or tee	2	2
	Two or more 90° bends in the same plane	2	2
	Two or more 90° bends in different plane	2	2
	Up to 10° of swirl	2	2
	Butterfly valve (75% open)	2	2
Downstream (outlet) side of primary	2	2	

# Rosemount Compact Orifice Flowmeter Series

**Product Data Sheet**  
00813-0100-4810, Rev FA  
August 2006

TABLE 15. 3095MFCCP Straight Pipe Requirements<sup>(1)(2)(3)</sup>

Beta	0.40		0.65	
	Reducer	5	12	
Upstream (inlet) side of primary	Single 90° bend or tee	16	44	
	Two or more 90° bends in the same plane	10	44	
	Two or more 90° bends in different plane	50	60	
Downstream (outlet) side of primary	Expander	12	28	
	Ball / Gate valve fully open	12	18	
		6	7	

- (1) Consult an Emerson Process Management representative if disturbance is not listed.
- (2) Recommended lengths represented in pipe diameters per ISO 5167.
- (3) Refer to ISO 5167 for recommended lengths when using flow straighteners.

## Pipe Orientation

Pipe orientation for both 3095MFCC Compact Conditioning Mass Orifice and standard 3095MFCCP Compact Mass Orifice.

Orientation/ Flow Direction	Process <sup>(1)</sup>		
	Gas	Liquid	Steam
Horizontal	D/R	D/R	D/R
Vertical Up	R	D/R	R
Vertical Down	D/R	NR	NR

- (1) D = Direct mount acceptable (recommended)  
R = Remote mount acceptable  
NR = Not recommended

## Pipe Centering

Improper centering of any orifice type device can cause an error of up to ±5% in small line sizes. A centering mechanism (centering ring) independent of flange rating comes standard with the 405 Compact Orifice Series.

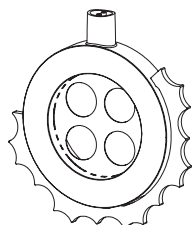

**3095MFCCD**  
Conditioning Orifice

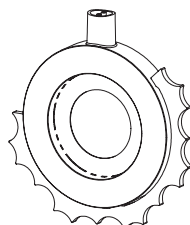

**3095MFCCD**  
Compact Orifice

## Flowmeter Orientation

Flowmeter orientation for both 3095MFC Conditioning Compact Orifice and standard Compact Orifice.

### Gas (Horizontal)

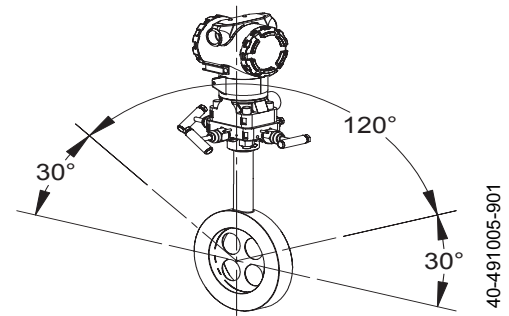

### Liquid and Steam (Horizontal)

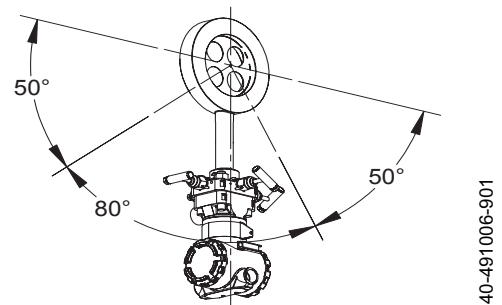

### Gas (Vertical)

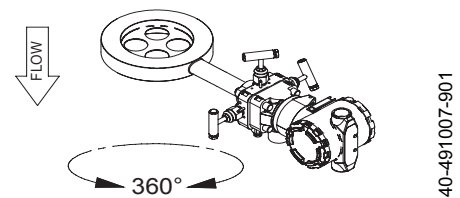

### Liquid (Vertical)

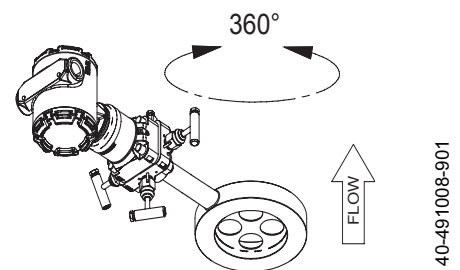

## PRODUCT CERTIFICATIONS

### Rosemount 3095 with HART

#### European Directive Information

The EC declaration of conformity for all applicable European directives for this product can be found on the Rosemount website at [www.rosemount.com](http://www.rosemount.com). A hard copy may be obtained by contacting our local sales office.

#### ATEX Directive (94/9/EC)

Emerson Process Management complies with the ATEX Directive.

#### European Pressure Equipment Directive (PED) (97/23/EC)

3095M\_2/3,4/D Flow Transmitters — QS Certificate of Assessment - EC No. PED-H-20  
Module H Conformity Assessment

All other 3095\_ Transmitters/Level Controller —  
Sound Engineering Practice

Transmitter Attachments: Process Flange - Manifold —  
Sound Engineering Practice

#### Electro Magnetic Compatibility (EMC) (89/336/EEC)

3095MV Flow Transmitters  
— EN 50081-1: 1992; EN 50082-2:1995;  
EN 61326-1:1997 – Industrial

#### Ordinary Location Certification for Factory Mutual

As standard, the transmitter has been examined and tested to determine that the design meets basic electrical, mechanical, and fire protection requirements by FM, a nationally recognized testing laboratory (NRTL) as accredited by the Federal Occupational Safety and Health Administration (OSHA).

## Hazardous Locations Certifications

### North American Certifications

#### FM Approvals

- E5 Explosion Proof for Class I, Division 1, Groups B, C, and D. Dust-Ignition Proof for Class II/Class III, Division 1, Groups E, F, and G. Enclosure type NEMA 4X. Factory Sealed. Provides nonincendive RTD connections for Class I, Division 2, Groups A, B, C, and D.
- I5 Intrinsically Safe for use in Class I, II and III, Division 1, Groups A, B, C, D, E, F, and G hazardous outdoor locations. Non-incendive for Class I, Division 2, Groups A, B, C, and D. Temperature Code T4. Factory Sealed.
- For input parameters and installation see control drawing 03095-1020.

#### Canadian Standards Association (CSA)

- E6 Explosion Proof for Class I, Division 1, Groups B, C, and D. Dust-Ignition Proof for Class II/Class III, Division 1, Groups E, F, and G. CSA enclosure Type 4X suitable for indoor and outdoor hazardous locations. Provides nonincendive RTD connection for Class I, Division 2, Groups A, B, C, and D. Factory Sealed. Install in accordance with Rosemount Drawing 03095-1024. Approved for Class I, Division 2, Groups A, B, C, and D.
- I6 Intrinsically Safe for Class I, Division 1, Groups A, B, C, and D. when installed in accordance with Rosemount drawing 03095-1021. Temperature Code T3C.
- For input parameters and installation see control drawing 03095-1021.

### European Certifications

- I1 ATEX Intrinsic Safety  
Certificate Number: BAS98ATEX1359X  II 1 G  
EEx ia IIC T5 (T<sub>amb</sub> = -45 °C to 40 °C)  
EEx ia IIC T4 (T<sub>amb</sub> = -45 °C to 70 °C)  
CE 1180

TABLE 16. Connection Parameters (Power/Signal Terminals)

U <sub>i</sub> = 30V
I <sub>i</sub> = 200 mA
P <sub>i</sub> = 1.0 W
C <sub>i</sub> = 0.012 μF
L <sub>i</sub> = 0

TABLE 17. Temperature Sensor Connection Parameters

U <sub>o</sub> = 30V
I <sub>o</sub> = 19 mA
P <sub>o</sub> = 140 mW
C <sub>i</sub> = 0.002 μF
L <sub>i</sub> = 0

TABLE 18. Temp Sensor Terminals Connection Parameters

C <sub>o</sub> = 0.066 μF	Gas Group IIC
C <sub>o</sub> = 0.560 μF	Gas Group IIB
C <sub>o</sub> = 1.82 μF	Gas Group IIA
L <sub>o</sub> = 96 mH	Gas Group IIC
L <sub>o</sub> = 365 mH	Gas Group IIB
L <sub>o</sub> = 696 mH	Gas Group IIA
L <sub>o</sub> /R <sub>o</sub> = 247 μH/ohm	Gas Group IIC
L <sub>o</sub> /R <sub>o</sub> = 633 μH/ohm	Gas Group IIB
L <sub>o</sub> /R <sub>o</sub> = 633 μH/ohm	Gas Group IIA

#### Special Conditions for Safe Use

The 3095, when fitted with the transient terminal block (order code B), are not capable of withstanding the 500 volts insulation test required by EN50 020, Clause 6.4.12 (1994). This condition must be accounted for during installation.

- N1 ATEX Type N  
Certificate Number: BAS98ATEX3360X  II 3 G  
EEx nL IIC T5 (T<sub>amb</sub> = -45 °C to 40 °C)  
EEx nL IIC T4 (T<sub>amb</sub> = -45 °C to 70 °C)  
U<sub>i</sub> = 55V

#### CE

The apparatus is designed for connection to a remote temperature sensor such as a resistance temperature detection (RTD)

## Special Conditions for Safe Use

The 3095, when fitted with the transient terminal block (order code B), are not capable of withstanding the 500 volts insulation test required by EN50 021, Clause 9.1 (1995). This condition must be accounted for during installation.

- E1 ATEX Flameproof  
Certificate Number: KEMA02ATEX2320X  II 1/2 G  
EEx d IIC T5 (-50°C ≤ T<sub>amb</sub> ≤ 80°C)  
T6 (-50°C ≤ T<sub>amb</sub> ≤ 65°C)  
CE 1180

## Special Conditions for Safe Use (x):

The device contains a thin wall diaphragm. Installation, maintenance, and use shall take into account the environmental conditions to which the diaphragm will be subjected. The manufacturer's instructions for installation and maintenance shall be followed in detail to assure safety during its expected lifetime.

- ND ATEX Dust  
Certificate Number: KEMA02ATEX2321  II 1 D  
V = 55 Vdc MAX  
I = 23 mA MAX  
IP66  
CE 1180

## Combinations of Certifications

Stainless steel certification tag is provided when optional approval is specified. Once a device labeled with multiple approval types is installed, it should not be reinstalled using any other approval types. Permanently mark the approval label to distinguish it from unused approval types.

- K5 E5 and I5 combination  
K6 E6 and I6 combination  
K1 I1, N1, E1, and ND combination

## Rosemount 3095 with *Fieldbus*

### European Directive Information

The EC declaration of conformity for all applicable European directives for this product can be found on the Rosemount website at [www.rosemount.com](http://www.rosemount.com). A hard copy may be obtained by contacting our local sales office.

### ATEX Directive (94/9/EC)

Emerson Process Management complies with the ATEX Directive.

### European Pressure Equipment Directive (PED) (97/23/EC)

3095F\_2/3,4/D and 3095M\_2/3,4/D Flow Transmitters  
— QS Certificate of Assessment - EC No. PED-H-20  
Module H Conformity Assessment  
All other 3095\_ Transmitters/Level Controller  
— Sound Engineering Practice  
Transmitter Attachments: Process Flange - Manifold  
— Sound Engineering Practice  
Primary Elements, Flowmeter  
— See appropriate Primary Element QIG

## Electro Magnetic Compatibility (EMC) (89/336/EEC)

3095 Flow Transmitters  
— EN 50081-1: 1992; EN 50082-2:1995; EN 61326-1:1997 – Industrial

## Ordinary Location Certification for Factory Mutual

As standard, the transmitter has been examined and tested to determine that the design meets basic electrical, mechanical, and fire protection requirements by FM, a nationally recognized testing laboratory (NRTL) as accredited by the Federal Occupational Safety and Health Administration (OSHA).

## Rosemount 3095 Fieldbus Hazardous Locations Certifications

### North American Certifications

#### FM Approvals

- E5 Explosion Proof for Class I, Division 1, Groups B, C, and D. Dust-Ignition Proof for Class II/Class III, Division 1, Groups E, F, and G. Enclosure type NEMA 4X. Factory Sealed. Provides nonincendive RTD connections for Class I, Division 2, Groups A, B, C, and D.  
I5 Intrinsically Safe for use in Class I, II and III, Division 1, Groups A, B, C, D, E, F, and G hazardous outdoor locations. Non-incendive for Class I, Division 2, Groups A, B, C, and D. Temperature Code T4. Factory Sealed.

For input parameters and installation see control drawing 03095-1020.

- IE FISCO for use in Class I, II and III, Division 1, Groups A, B, C, D, E, F, and G hazardous outdoor locations. Temperature Code T4. Factory Sealed.

For input parameters and installation see control drawing 03095-1020.

#### Combinations of Certifications

Stainless steel certification tag is provided when optional approval is specified. Once a device labeled with multiple approval types is installed, it should not be reinstalled using any other approval types. Permanently mark the approval label to distinguish it from unused approval types.

- K5 E5 and I5 combination

### Canadian Standards Association (CSA)

- IF CSA FISCO Intrinsically Safe; for FOUNDATION fieldbus protocol only

### European Certifications

- IA ATEX FISCO Intrinsically Safe; for FOUNDATION fieldbus protocol only

### Australian Certifications

- IG IECEx FISCO Intrinsic Safety



**DIMENSIONAL DRAWINGS**

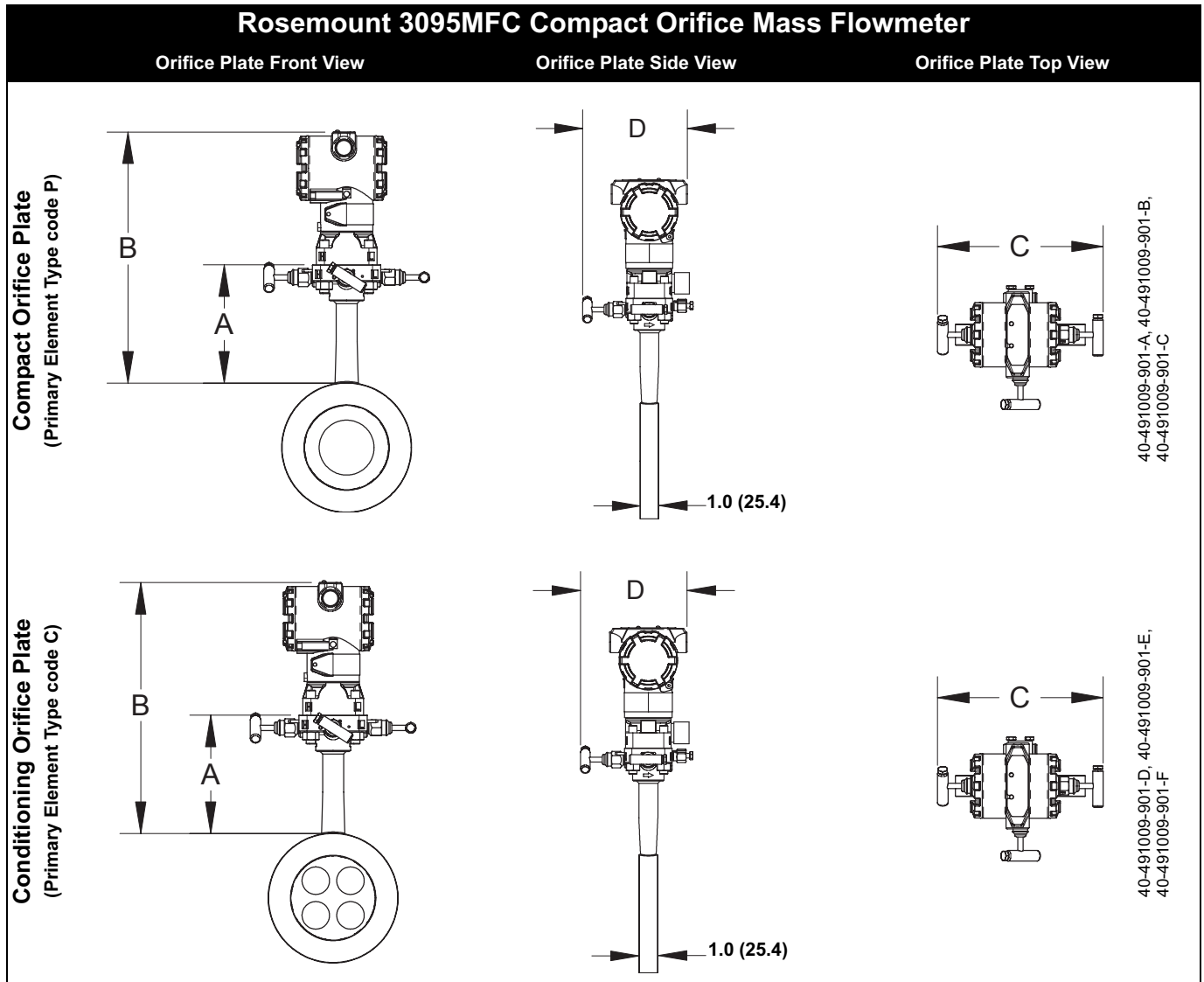

TABLE 19. Dimensional Drawings<sup>(1)</sup>

Plate Type	A	B	Transmitter Height	C	D
Type P & C	6.00 (152)	Transmitter Height + A	6.25-in. (159)	7.75 (197) - closed 8.25 (210) - open	6.00-in. (152) - closed 6.25-in. (159) - open

<sup>(1)</sup> Measurement is in inches (millimeters).

# Rosemount Compact Orifice Flowmeter Series

**Product Data Sheet**  
00813-0100-4810, Rev FA  
August 2006

## ORDERING INFORMATION

### Rosemount 3095MFC Compact Orifice Mass Flowmeter Ordering Information

Model	Product Description	
3095MFC	Compact Orifice Mass Flowmeter	
Code	Primary Element Type	
C	Conditioning Orifice Plate	
P	Orifice Plate	
Code	Material Type	
S	316 Stainless Steel (SST)	
Code	Line Size	
005 <sup>(1)</sup>	1/2-in. (15 mm)	
010 <sup>(1)</sup>	1-in. (25 mm)	
015 <sup>(1)</sup>	1 1/2-in. (40 mm)	
020	2-in. (50 mm)	
030	3-in. (80 mm)	
040	4-in. (100 mm)	
060	6-in. (150 mm)	
080	8-in. (200 mm)	
Code	Primary Element Style	
N	Square Edged	
Code	Beta Ratio	
040	0.40 Beta Ratio ( $\beta$ )	
065 <sup>(2)</sup>	0.65 Beta Ratio ( $\beta$ )	
Code	Temperature Measurement	
R	Remote Thermowell and RTD	
0	No Temperature Sensor	
Code	Electronics Connection Platform	
3	Direct-mount, 3-valve integral manifold, SST	
7	Remote-mount, 1/4-in. NPT connections	
Code	Differential Pressure Range	
1	0 to 25 in H <sub>2</sub> O (0 to 62.2 mbar)	
2	0 to 250 in H <sub>2</sub> O (0 to 623 mbar)	
3	0 to 1000 in H <sub>2</sub> O (0 to 2.5 bar)	
Code	Static Pressure Range	
B	0 – 8 to 0 – 800 psia (0 –55.16 to 0 – 5515.8 kPa)	
C	0 – 8 to 0 – 800 psig (0 –55.16 to 0 – 5515.8 kPa)	
D	0 – 36.2 to 0 – 3626 psia (0 –250 to 0 – 25000 kPa)	
E	0 – 36.2 to 0 – 3626 psig (0 –250 to 0 – 25000 kPa)	
Code	Output Protocol	
A	4–20 mA with digital signal based on <i>HART</i> protocol	
V	<i>FOUNDATION</i> fieldbus protocol	
Code	Transmitter Housing Material	Conduit Entry Size
1A	Polyurethane-covered aluminum	1/2-14 NPT
1B	Polyurethane-covered aluminum	M20 x 1.5 (CM20)
1C	Polyurethane-covered aluminum	PG 13.5
1J	SST	1/2-14 NPT
1K	SST	M20 x 1.5 (CM20)
1L	SST	PG 13.5

**Rosemount 3095MFC Compact Orifice Mass Flowmeter Ordering Information**

<b>Code</b>	<b>Options</b>
<b>Performance Class</b>	
U3 <sup>(3)</sup>	Ultra for Flow: up to ±0.75% mass flow rate accuracy, up to 10:1 turndown, 10-year stability, limited 12-year warranty
<b>PlantWeb Control Functionality</b>	
A01 <sup>(4)</sup>	Advanced Control Function Block Suite
<b>Installation Accessories</b>	
G	DIN alignment ring (PN 16)
H	DIN alignment ring (PN 40, PN 100)
B	JIS Alignment Ring 10K
R	JIS Alignment Ring 20K
S	JIS Alignment Ring 40K
<b>Remote Adapters</b>	
E	Flange adapters 316 SST (1/2-in. NPT)
<b>High Temperature Applications</b>	
T	Graphite valve packing (Tmax = 850 °F)
<b>Flow Calibration</b>	
WC <sup>(5)</sup>	Discharge coefficient verification (3 point)
WD <sup>(5)</sup>	Discharge coefficient verification (full 10 point)
<b>Pressure Testing</b>	
P1	Hydrostatic Testing with certificate
<b>Special Cleaning</b>	
P2	Cleaning for special processes
PA	Cleaning per ASTM G93 Level D (section 11.4)
<b>Special Inspection</b>	
QC1	Visual and dimensional inspection with certificate
QC7	Inspection and performance certificate
<b>Transmitter Calibration Certification</b>	
Q4	Calibration data certificate for transmitter
<b>Material Traceability Certification</b>	
Q8	Material certification per ISO 10474 3.1.B and EN 10204 3.1.B
<b>Code Conformance</b>	
J2	ANSI B31.1
J3	ANSI B31.3
J4	ANSI B31.8
J5 <sup>(6)</sup>	NACE MR-0175 / ISO 15156
<b>Country Certification</b>	
J1	Canadian Registration
<b>Product Certifications</b>	
E1	ATEX Flameproof
I1	ATEX Intrinsically Safe
N1	ATEX Type n
K1	ATEX Flameproof, Intrinsically Safe, Type n, and Dust (combination of E1, I1, N1, and ND)
ND	ATEX Dust
E5	FM Explosion proof
I5	FM Intrinsically Safe, non-incendive
K5	FM Explosion-proof, Intrinsically Safe, Non-Incendive
E6	CSA Explosion proof
I6	CSA Intrinsically Safe, Division 2
K6	CSA Explosion-proof, Intrinsically Safe, Division 2
IE <sup>(7)</sup>	FM FISCO Intrinsically Safe; for FOUNDATION fieldbus protocol only
IF <sup>(7)</sup>	CSA FISCO Intrinsically Safe; for FOUNDATION fieldbus protocol only
IA <sup>(7)</sup>	ATEX FISCO Intrinsically Safe; for FOUNDATION fieldbus protocol only
IG <sup>(7)</sup>	IECEx FISCO Intrinsically Safe

# Rosemount Compact Orifice Flowmeter Series

**Product Data Sheet**  
00813-0100-4810, Rev FA  
August 2006

## Rosemount 3095MFC Compact Orifice Mass Flowmeter Ordering Information

### Alternative Transmitter Material of Construction

L1 Inert Sensor Fill Fluid

### Display

M5 Integral mount LCD display

### Terminal Blocks

T1 Transient Protection

### Manifold for Remote Mount Option

F2 3-Valve Manifold, SST

F6 5-Valve Manifold, SST

**Typical Model Number: 3051MFC C S 040 N 040 0 3 B A 1A**

- (1) Not available for Primary Element Type code C.
- (2) For 2-in. (50.8 mm) line sizes the Beta Ratio is 0.6 for Primary Element Type code C.
- (3) Ultra for Flow applicable for HART protocol, DP ranges 2 and 3 with SST isolator material and silicone fill fluid options only.
- (4) Function Blocks include: Arithmetic, Integrator, Analog Output, Signal Characterizer, Control Selector, and Output Selector.
- (5) Not available with Primary Element Type code P.
- (6) Materials of Construction comply with metallurgical requirements within NACE MR0175/ISO 15156 for sour oil field production environments. Environmental limits apply to certain materials. Consult latest standard for details. Selected materials also conform to NACE MR0103 for sour refining environments.
- (7) Consult factory for availability.

## Rosemount 405 Compact Orifice Primary Element

### SPECIFICATIONS

#### Performance

##### Discharge Coefficient Uncertainty

TABLE 20. 405 Compact Orifice Primary Element

Type	Beta	Discharge Coefficient Uncertainty
405C	0.4	±0.50%
(Conditioning Compact)	0.65	±0.75%
405P <sup>(1)(2)</sup>	0.4	±1.75%
(Standard Compact)	0.65	±1.75%
405P <sup>(3)</sup>	0.4	±1.25%
(Standard Compact)	0.65	±1.25%

(1) Line sizes  $1/2$  to  $1\ 1/2$ -in. (12.7 to 38.1 mm).

(2) Discharge Coefficient Uncertainty for  $1/2$ -in. units with Beta = 0.65 is ±2.25%.

(3) Line sizes 2 to 8-in. (50.8 to 203.2 mm)

#### Line Sizes

- $1/2$ -in. (15 mm) – not available for the 405C
- 1-in. (25 mm) – not available for the 405C
- $1\ 1/2$ -in. (40 mm) – not available for the 405C
- 2-in. (50 mm)
- 3-in. (80 mm)
- 4-in. (100 mm)
- 6-in. (150 mm)
- 8-in. (200 mm)

#### Sizing

Contact an Emerson Process Management sales representative assistance. A "Configuration Data Sheet" is required prior to order for application verification.

### Functional

#### Service

- Liquid
- Gas
- Vapor

#### Operating Process Temperature Limits

Standard (direct/remote mount):

- -40 to 450 °F (-40 to 232 °C)

Extended (remote mount only with option code T):

- -148 to 850 °F (-100 to 454 °C)

#### Maximum Working Pressure

- Pressure retention per ANSI B16.5 600# or DIN PN100

#### Assembly to a transmitter

Select option code C11 for the Rosemount 3051S transmitter (or option code S3 for the Rosemount 3051C or 3095MV transmitters) to factory assemble the Rosemount 405 to a Rosemount pressure transmitter. If the 405 and transmitter are not factory assembled, they may be shipped separately. For a consolidated shipment, inform the Emerson Process Management representative when placing the order.

### Physical

#### Material of Construction

Body/Plate

- 316 SST

Manifold Head/Valves

- 316 SST

Flange Studs and Nuts

- Customer supplied
- Available as a spare part

Transmitter Connection Studs and Nuts

- Studs– A193 Grade B8M.
- Nuts– A194 Grade 8M.

Gasket and O-rings

- Gaskets are customer supplied.
- Durlon 8500 fiber gaskets are recommended. Consult an Emerson Process Management representative for use with other gaskets.
- Available as a spare part

#### NOTE

Gaskets and O-rings should be replaced when the 405 is disassembled.

#### Transmitter Connections

Direct Mount

- Integrally mount to 3051 and 3095 transmitters, range 1, 2, and 3.

Remote Mount

- Available with  $1/4$ -in. (standard) or  $1/2$ -in. (option code E) connections

Orifice Plate Type

- Square edged
- Corner tapped
- Concentric
- Wafer-style

# Rosemount Compact Orifice Flowmeter Series

**Product Data Sheet**  
00813-0100-4810, Rev FA  
August 2006

## Process Connections

Mounts between the following flange configurations:

ASME B16.5 (ANSI)	DIN	JIS
Class 150	PN16 (option code G)	10k (option code B)
Class 300	PN40 (option code H)	20k (option code R)
Class 600	PN100 (option code H)	40k (option code S)

ANSI alignment ring is included as standard when ordering.

## Typical Orifice Hole Sizes (For 405C)

Beta is calculated by:  $\beta = d_C / \text{Pipe ID}$ , where the calculated bore is equal to 2 x typical orifice hole size ( $d_C = 2d$ ). The table below shows the diameter of each of the four typical orifice holes.

TABLE 21.  $\beta = 0.4^{(1)(2)}$

Line Size	405C	405P
1/2-in. (15 mm)	Not Available	0.249 (6.325)
1-in. (25 mm)	Not Available	0.420 (10.668)
1 1/2-in. (40 mm)	Not Available	0.644 (16.358)
2-in. (50 mm)	0.413 (10.490)	0.827 (21.006)
3-in. (80 mm)	0.614 (15.596)	1.227 (31.166)
4-in. (100 mm)	0.805 (20.447)	1.610 (40.894)
6-in. (150 mm)	1.213 (30.810)	2.426 (61.620)
8-in. (200 mm)	1.596 (40.538)	3.192 (81.077)

TABLE 22.  $\beta = 0.65^{(1)(2)}$

Line Size	405C	405P
1/2-in. (15 mm)	Not Available	0.404 (10.262)
1-in. (25 mm)	Not Available	0.682 (17.323)
1 1/2-in. (40 mm)	Not Available	1.047 (26.594)
2-in. (50 mm)	0.620 (15.748) <sup>(3)</sup>	1.344 (34.138)
3-in. (80 mm)	0.997 (25.324)	1.994 (50.648)
4-in. (100 mm)	1.308 (33.223)	2.617 (66.472)
6-in. (150 mm)	1.971 (50.063)	3.942 (100.127)
8-in. (200 mm)	2.594 (65.888)	5.188 (131.775)

(1) Measurement is in inches (millimeters)

(2) Tolerance =  $\pm 0.002$ -in.

(3) Beta ( $\beta$ ) = 0.60 (15.24 mm) for 2-in. line size only.

## Weight

Line Size (in.)	Direct Mount (D3) <sup>(1)</sup>	Remote Mount (R3) <sup>(1)</sup>
1/2-in. (15 mm)	4.0 (1.81)	8.0 (3.63)
1-in. (25 mm)	4.5 (2.04)	8.5 (3.86)
1 1/2-in. (40 mm)	5.25 (2.38)	9.25 (4.20)
2-in. (50 mm)	6.0 (2.72)	10 (4.54)
3-in. (80 mm)	6.75 (3.06)	11.75 (5.33)
4-in. (100 mm)	7.75 (3.52)	13.5 (6.12)
6-in. (150 mm)	13.25 (6.01)	17.25 (7.82)
8-in. (200 mm)	17.75 (8.05)	21.75 (9.87)

(1) Measurement in lb (kg).

## Installation Consideration

### Straight Pipe Requirement

Use the appropriate lengths of straight pipe upstream and downstream of the 405 to minimize the effects of moderate flow disturbances in the pipe. Table 23 and Table 24 lists recommended lengths of straight pipe per ISO 5167.

TABLE 23. 405C Straight Pipe Requirements<sup>(1)</sup>

Beta	0.40	0.65	
Upstream (inlet) side of primary	Reducer (1 line size)	2	2
	Single 90° bend or tee	2	2
	Two or more 90° bends in the same plane	2	2
	Two or more 90° bends in different plane	2	2
	Up to 10° of swirl	2	2
	Butterfly valve (75% open)	2	2
	Downstream (outlet) side of primary	2	2

TABLE 24. 405P Straight Pipe Requirements<sup>(1)(2)(3)</sup>

Beta	0.40	0.65	
Upstream (inlet) side of primary	Reducer	5	12
	Single 90° bend or tee	16	44
	Two or more 90° bends in the same plane	10	44
	Two or more 90° bends in different plane	50	60
	Expander	12	28
	Ball / Gate valve fully open	12	18
	Downstream (outlet) side of primary	6	7

(1) Consult an Emerson Process Management representative if disturbance is not listed.

(2) Recommended lengths represented in pipe diameters per ISO 5167.

(3) Refer to ISO 5167 for recommended lengths when using flow straighteners.

### Pipe Orientation

Orientation/ Flow Direction	Process <sup>(1)</sup>		
	Gas	Liquid	Steam
Horizontal	D/R	D/R	D/R
Vertical Up	R	D/R	R
Vertical Down	D/R	NR	NR

(1) D = Direct mount acceptable (recommended)  
 R = Remote mount acceptable  
 NR = Not recommended

### Pipe Centering

Improper centering of any orifice type device can cause an error of up to ±5% in small line sizes. A centering mechanism (centering ring) independent of flange rating comes standard with the 405 Compact Orifice Series.

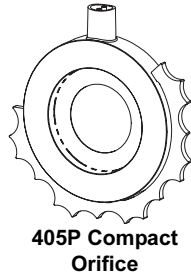

### Flowmeter Orientation

Flowmeter orientation for the Conditioning Compact Orifice and standard Compact Orifice.

#### Gas (Horizontal)

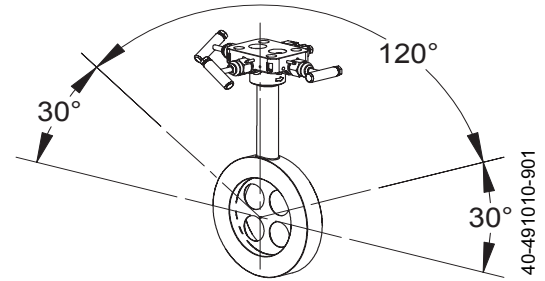

#### Liquid and Steam (Horizontal)

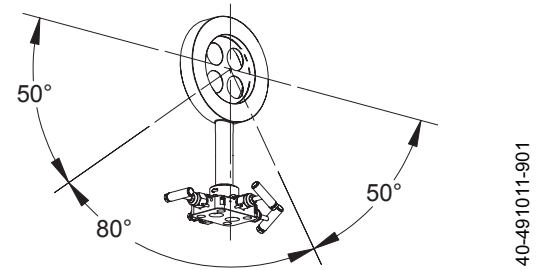

#### Gas (Vertical)

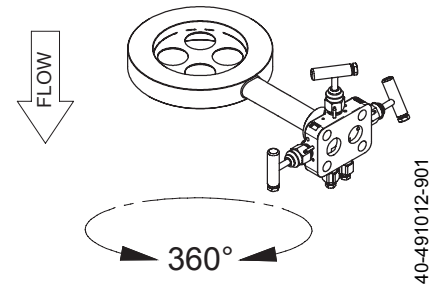

#### Liquid (Vertical)

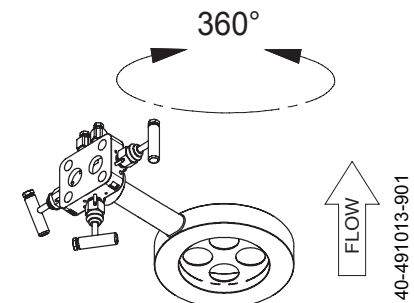

## DIMENSIONAL DRAWINGS

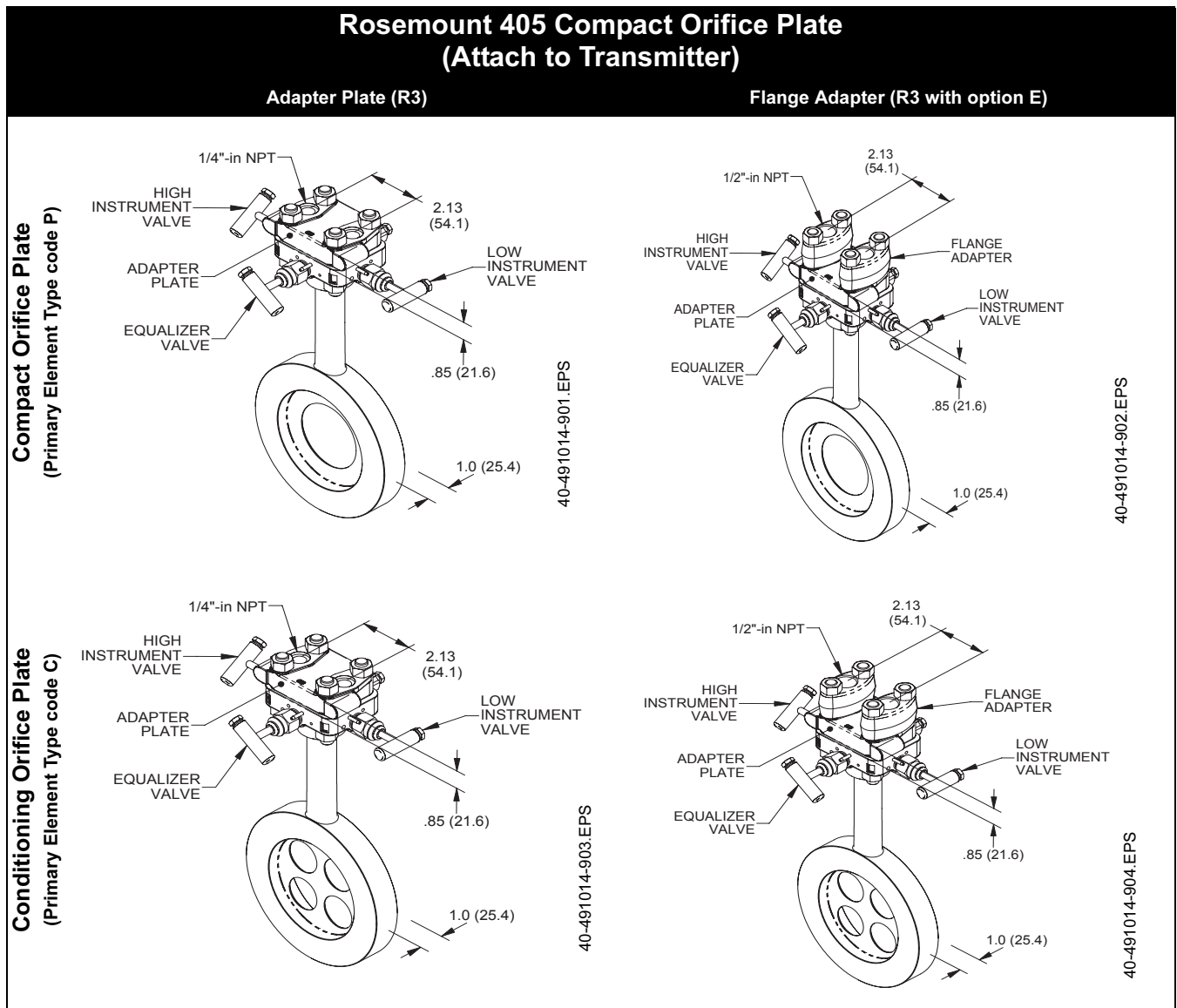



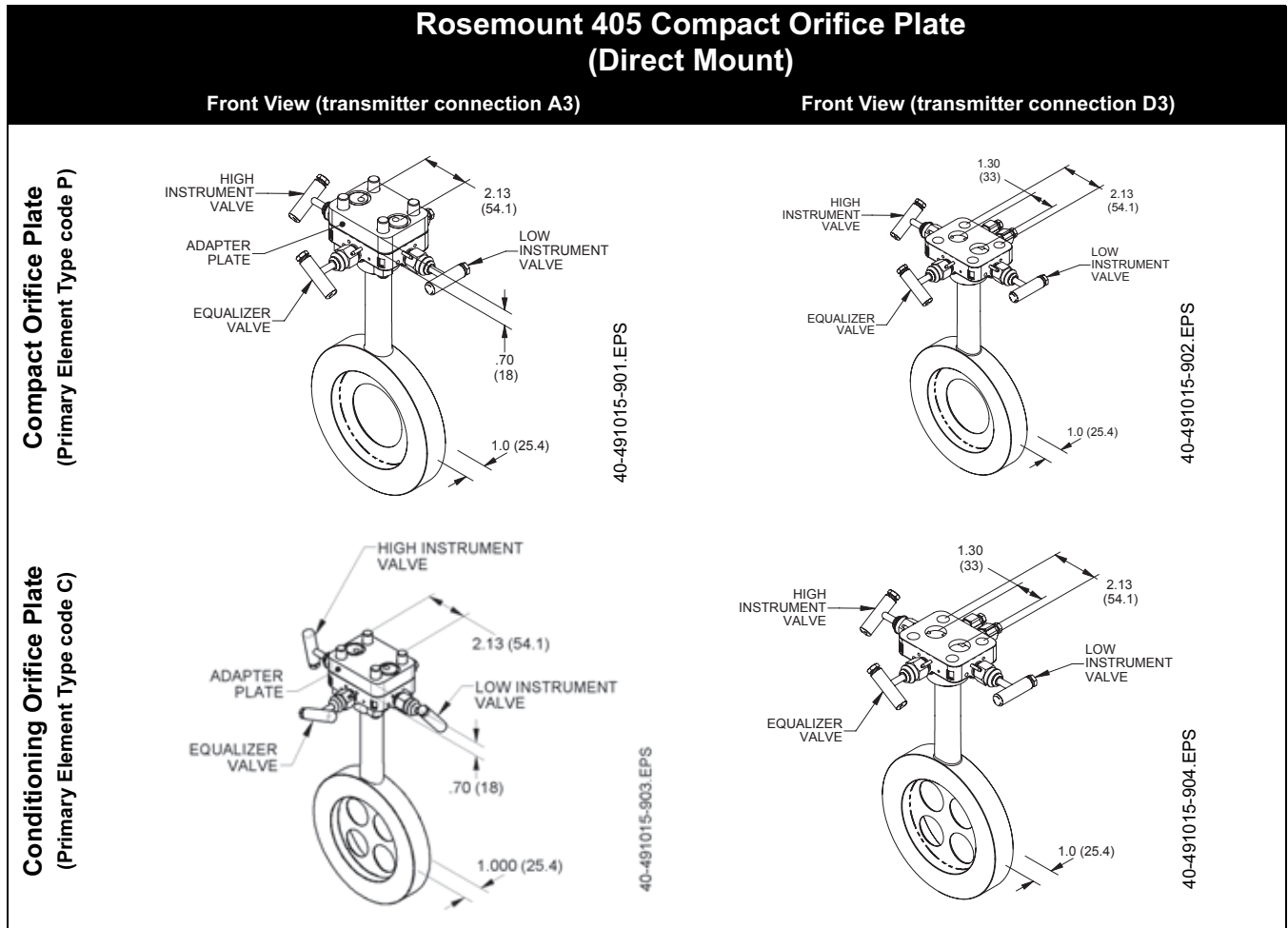

**NOTE**

Transmitter connection code A3 is to be used with a traditional style transmitter (such as a Rosemount 1151). This is a stainless steel adapter plate for allowing the direct mount of traditional style transmitters.

# Rosemount Compact Orifice Flowmeter Series

**Product Data Sheet**  
00813-0100-4810, Rev FA  
August 2006

## ORDERING INFORMATION

### Rosemount 405 Compact Orifice Primary Element Ordering Information

Model	Product Description
405	Compact Primary Element
Code	Primary Element Type
C	Conditioning Orifice Plate
P	Orifice Plate
Code	Material Type
S	316 Stainless Steel (SST)
Code	Line Size
005 <sup>(1)</sup>	1/2-in. (15 mm)
010 <sup>(1)</sup>	1-in. (25 mm)
015 <sup>(1)</sup>	1 1/2-in. (40 mm)
020	2-in. (50 mm)
030	3-in. (80 mm)
040	4-in. (100 mm)
060	6-in. (150 mm)
080	8-in. (200 mm)
Code	Primary Element Style
N	Square Edged
Code	Beta Ratio
040	0.40 Beta Ratio ( $\beta$ )
065 <sup>(2)</sup>	0.65 Beta Ratio ( $\beta$ )
Code	Transmitter Connection
D3	<i>Coplanar</i> , Direct mount, 3-valve integral manifold, SST
R3	Remote-mount, 1/4-in. NPT connections
A3	Traditional, Direct mount, 3-valve integral manifold with adapter plate, SST
Code	Options
Installation Accessories	
G	DIN alignment ring (PN 16)
H	DIN alignment ring (PN 40, PN 100)
B	JIS Alignment Ring 10K
R	JIS Alignment Ring 20K
S	JIS Alignment Ring 40K
Adapters	
E	Flange adapters 316 SST (1/2-in. NPT)
High Temperature Applications	
T	Graphite valve packing (Tmax = 850 °F)
Flow Calibration	
WC <sup>(3)</sup>	Discharge coefficient verification (3 point)
WD <sup>(3)</sup>	Discharge coefficient verification (full 10 point)
Pressure Testing	
P1	Hydrostatic testing with certificate
Special Cleaning	
P2	Cleaning for special processes
PA	Cleaning per ASTM G93 Level D (section 11.4)
Continued on Next Page	

---

**Rosemount 405 Compact Orifice Primary Element Ordering Information**

**Special Inspection**

QC1	Visual and Dimensional Inspection with certification
QC7	Inspection and performance certification

**Material Traceability Certification**

Q8	Material certification per ISO 10474 3.1.B and EN 10204 3.1.B
----	---

**Code Conformance**

J2	ANSI B31.1
J3	ANSI B31.3
J4	ANSI B31.8
J5 <sup>(4)</sup>	NACE MR-0175 / 15156

**Country Certification**

J1	Canadian Registration
----	-----------------------

**Typical Model Number: 405 C S 040 N 040 D3**

- (1) Not available for Primary Element Type code C.
- (2) For 2-in. (50.8 mm) line sizes the Beta Ratio is 0.6 for Primary Element Type code C.
- (3) Not available with Primary Element Type code P.
- (4) Materials of Construction comply with metallurgical requirements within NACE MR0175/ISO for sour oil field production environments. Environmental limits apply to certain materials. Consult latest standard for details. Selected materials also conform to NACE MR0103 for sour refining environments.

## HART Configuration Data Sheet (CDS)

### DP FLOW CDS

Complete this form to define a custom flow configuration for DP Flowmeters. Unless specified, the flowmeter will be shipped with the default values identified by the H symbol.

For technical assistance in filling out this CDS, call a Rosemount representative.

#### NOTE

Any missing information will be processed with the indicated default values.

\* = Required Item

★ = Default

#### Customer Information

Customer: \_\_\_\_\_ Contact Name: \_\_\_\_\_  
Customer Phone: \_\_\_\_\_ Customer Fax: \_\_\_\_\_  
Customer Approval Sign-Off: \_\_\_\_\_ Customer PO: \_\_\_\_\_

#### Calculation Approval

Check this box if a calculation for approval prior to manufacturing is required

#### Application and Configuration Data Sheet (Required with Order)

Tag: \_\_\_\_\_

Model No <sup>(1)</sup> \_\_\_\_\_

\* Select fluid type       Liquid       Gas       Steam

\* Fluid name<sup>(2)</sup> \_\_\_\_\_

#### Flowmeter Information (optional)

\* Failure Mode Alarm Direction (select one)       Alarm High★       Alarm Low

Software Tag: \_\_\_\_\_ (8 characters)

Descriptor: \_\_\_\_\_ (16 characters)

Message: \_\_\_\_\_  
\_\_\_\_\_ (32 characters)

Date:      Day \_\_\_ (numeric)      Month \_\_\_ (numeric)      Year \_\_\_ (numeric)

(1) A complete model number is required before Rosemount Inc. can process the order.

(2) If the Fluid is not located in Table 25 on page 38, the "Fluid Data Sheet (FDS)" on page 42 must be completed.

#### For Rosemount Use Only

S.O.: \_\_\_\_\_ LI  
CHAMP: \_\_\_\_\_ DATE:  
ADMIN:

\* = Required Item  
★ = Default

**Primary Element Information**

\* Select Differential Producer (Select One)

**Annubar**

- 485 Annubar/ 3095MFA Mass ProBar, 3051SFA ProBar
- 285 Annubar
- Annubar Diamond II + / Mass Probar
- Long Radius Wall Taps, ASME
- Long Radius Wall Taps, ISO
- ISA 1932, ISO

**Venturi**

- Nozzle, ISO
- Rough Cast/Fabricated Inlet, ASME
- Round Cast Inlet, ISO
- Machined Inlet, ASME
- Machined Inlet, ISO
- Welded Inlet, ISO

**Other (All options require a discharge coefficient value)**

- Calibrated Orifice: Flange, Corner, or D & D/2 Taps.

Discharge coefficient: \_\_\_\_\_

- Calibrated Orifice: 2<sup>1</sup>/<sub>2</sub> D & 8D Taps

Discharge coefficient: \_\_\_\_\_

- Calibrating Nozzle

Discharge coefficient: \_\_\_\_\_

- Calibrating Venturi

Discharge coefficient: \_\_\_\_\_

- Area Averaging Meter

Discharge coefficient: \_\_\_\_\_

- V-Cone®

Discharge coefficient: \_\_\_\_\_

Diameter (d) \_\_\_\_\_

**Orifice**

- 3051SFP, 3095MFP, 1195
- 405C, 405P, 3051SFC, 3095MFC
- 1595 Conditioning Orifice
- 2<sup>1</sup>/<sub>2</sub>D & 8D Taps, ASME
- Corner Taps, ASME
- Corner Taps, ISO
- D & D/2 Taps, ASME
- D & D/2 Taps, ISO
- D & D/2 Taps, ISO 99 Amendment 1
- Flange Taps, AGA
- Flange Taps, ASME
- Flange Taps, ISO
- Flange Taps, ISO 99 Amendment 1
- Small Bore, Flange Taps, ASME

inch★

millimeters

at \_\_\_\_\_

°F

°C

68 °F★

ODF \_\_\_\_\_

ODT \_\_\_\_\_

Special Annubar dimension (required if customer supplies mounting hardware).

**Pipe Information**

\* Orientation / Flow Direction:  Vertical Up  Vertical Down  Horizontal

\* Line Size / Schedule: \_\_\_\_\_ Body I.D. (D): \_\_\_\_\_

**Materials of Construction**

\* Pipe Material  Carbon Steel  304 SST  316 SST  Hastelloy  Other \_\_\_\_\_

\* Primary Element Material  316 SST  Hastelloy  Other \_\_\_\_\_ (Please verify material availability)

**Operating Conditions**

	4 mA value	Minimum	Normal	Maximum	Full Scale:20 mA flow rate (design to P and T)	Design
Flow Rate	0	*(1)	*	*		
Pressure (P)	—	*(1)	*	*(1)	*(2)	
Temperature (T)	—	*(1)	*	*(1)	*	

**RTD Mode**

Normal Mode ★ (Requires a RTD to be connected. If the RTD is disconnected or fails, the 3095MV output goes to alarm value)

Fixed Temperature Mode: Specify the fixed temperature value \_\_\_\_\_  °F  °C

Backup Mode (Uses the connected RTD for temperature measurement. If the RTD is disconnected or fails, the transmitter uses a fixed temperature value as a backup. This will not cause the mA output to go to alarm value and can potentially cause inaccurate flow measurement.) Fixed temperature value to be used as backup \_\_\_\_\_  °F  °C

# Rosemount Compact Orifice Flowmeter Series

**Product Data Sheet**  
00813-0100-4810, Rev FA  
August 2006

\* = Required Item

★ = Default

## Base Conditions

Standard Base (P=14.696 psia / 101.325 kPa abs, T= 60 °F (15.56 °C))

Normal Base (P=14.696 psia / 101.325 kPa abs, T= 32 °F (0 °C))

Standard Base for Natural Gas (AGA) (P=14.73 psia, T= 60°F (15.56 °C))

User Defined: P= \_\_\_\_\_ Units: \_\_\_\_\_ T= \_\_\_\_\_ Units = \_\_\_\_\_

Compressibility at Base: \_\_\_\_\_ OR Density at Base: \_\_\_\_\_

(1) Operating ranges for pressure and temperature are needed for transmitter configuration.

(2) Required to verify that the product selection meets design criteria.

TABLE 25. Rosemount Fluids Database<sup>(1)</sup>

Acetic Acid	Divinyl Ether	Methane	n-Hexane	1-Heptanol
Acetone	Ethane	Methanol	n-Octane	1-Heptene
Acetonitrile	Ethanol	Methyl Acrylate	n-Pentane	1-Hexene
Acetylene	Ethylamine	Methyl Ethyl Ketone	Oxygen	1-Hexadecanol
Acrylonitrile	Ethylbenzene	Methyl Vinyl Ether	Pentafluorothane	1-Octanol
Air	Ethylene	m-Chloronitrobenzene	Phenol	1-Octene
Allyl Alcohol	Ethylene Glycol	Neon	Propadiene	1-Nonanol
Ammonia	Ethylene Oxide	Neopentane	Pyrene	1-Pentadecanol
Argon	Fluorene	Nitric Acid	Propylene	1-Pentanol
Benzene	Furan	Nitric Oxide	Styrene	1-Pentene
Benzaldehyde	Helium-4	Nitrobenzene	Sulfur Dioxide	1-Undecanol
Benzyl Alcohol	Hydrazine	m-Dichlorobenzene	Propane	1-Nonanal
Biphenyl	Hydrogen	Nitroethane	Toluene	1,2,4- Trichlorobenzene
Carbon Dioxide	Hydrogen Chloride	Nitrogen	Trichloroethylene	1,1,2- Trichloroethane
Carbon Monoxide	Hydrogen Cyanide	Nitromethane	Vinyl Acetate	1,1,2,2- Tetrafluoroethane
Carbon Tetrachloride	Hydrogen Peroxide	Nitrous Oxide	Vinyl Chloride	1,2-Butadiene
Chlorine	Hydrogen Sulfide	n-Butane	Vinyl Cyclohexane	1,3-Butadiene
Chlorotrifluoroethylene	Isobutane	n-Butanol	Water	1,3,5- Trichlorobenzene
Chloroprene	Isobutene	n-Butyraldehyde	1-Butene	1,4-Dioxane
Cycloheptane	Isobutyl benzene	n-Butyronitrile	1-Decene	1,4-Hexadiene
Cyclohexane	Isopentane	n-Decane	1-Decanal	2-Methyl-1-Pentene
Cyclopentane	Isoprene	n-Dodecane	1-Decanol	2,2-Dimethylbutane
Cyclopentene	Isopropanol	n-Heptadecane	1-Dodecene	
Cyclopropane		n-Heptane	1-Dodecanol	

(1) This list is subject to change without notice. Steam per ASME Steam tables. All other fluids per AIChE.

## Drawing/Notes

## FOUNDATION fieldbus™ Configuration Data Sheet (CDS)

### DP FLOW CDS

Complete this form to define a custom flow configuration for DP Flowmeters. Unless specified, the flowmeter will be shipped with the default values identified by the H symbol.

For technical assistance in filling out this CDS, call a Rosemount representative.

#### NOTE

Any missing information will be processed with the indicated default values.

\* = Required Item

★ = Default

#### Customer Information

Customer:	Contact Name:
Customer Phone:	Customer Fax:
Customer Approval Sign-Off:	Customer PO:

#### Calculation Approval

Check this box if a calculation for approval prior to manufacturing is required

#### Application and Configuration Data Sheet (Required with Order)

Tag:

Model No <sup>(1)</sup>

\* **Select fluid type**       Liquid       Gas       Steam

\* **Fluid name**<sup>(2)</sup>

#### Flowmeter Information (optional)

\* Failure Mode Alarm Direction (select one)       Alarm High★       Alarm Low

Software Tag: \_\_\_\_\_ (16 characters)

Descriptor: \_\_\_\_\_  
 \_\_\_\_\_ (32 characters)

Message: \_\_\_\_\_  
 \_\_\_\_\_ (32 characters)

Date:                      Day \_\_\_ (numeric)      Month \_\_\_ (numeric)      Year \_\_\_ (numeric)

(1) A complete model number is required before Rosemount Inc. can process the order.

(2) If the Fluid is not located in Table 26 on page 41, the "Fluid Data Sheet (FDS)" on page 42 must be completed.

#### For Rosemount Use Only

S.O.:	LI
CHAMP:	DATE:
	ADMIN:

# Rosemount Compact Orifice Flowmeter Series

**Product Data Sheet**  
00813-0100-4810, Rev FA  
August 2006

\* = Required Item  
★ = Default

## Primary Element Information

\* Select Differential Producer (Select One)

### Annubar

- 485 Annubar/ 3095MFA Mass ProBar, 3051SFA ProBar
- 285 Annubar
- Annubar Diamond II + / Mass Probar
- Long Radius Wall Taps, ASME
- Long Radius Wall Taps, ISO
- ISA 1932, ISO

### Venturi

- Nozzle, ISO
- Rough Cast/Fabricated Inlet, ASME
- Round Cast Inlet, ISO
- Machined Inlet, ASME
- Machined Inlet, ISO
- Welded Inlet, ISO

### Other (All options require a discharge coefficient value)

- Calibrated Orifice: Flange, Corner, or D & D/2 Taps.

Discharge coefficient: \_\_\_\_\_

- Calibrated Orifice: 2<sup>1</sup>/<sub>2</sub> D & 8D Taps

Discharge coefficient: \_\_\_\_\_

- Calibrating Nozzle

Discharge coefficient: \_\_\_\_\_

- Calibrating Venturi

Discharge coefficient: \_\_\_\_\_

- Area Averaging Meter

Discharge coefficient: \_\_\_\_\_

- V-Cone®

Discharge coefficient: \_\_\_\_\_

Diameter (d) \_\_\_\_\_

### Orifice

- 3051SFP, 3095MFP, 1195
- 405C, 405P, 3051SFC, 3095MFC
- 1595 Conditioning Orifice
- 2<sup>1</sup>/<sub>2</sub>D & 8D Taps, ASME
- Corner Taps, ASME
- Corner Taps, ISO
- D & D/2 Taps, ASME
- D & D/2 Taps, ISO
- D & D/2 Taps, ISO 99 Amendment 1
- Flange Taps, AGA
- Flange Taps, ASME
- Flange Taps, ISO
- Flange Taps, ISO 99 Amendment 1
- Small Bore, Flange Taps, ASME

inch★

millimeters

at \_\_\_\_\_

°F

°C

68 °F★

ODF \_\_\_\_\_

ODT \_\_\_\_\_

Special Annubar dimension (required if customer supplies mounting hardware).

## Pipe Information

\* Orientation / Flow Direction:  Vertical Up  Vertical Down  Horizontal

\* Line Size / Schedule: \_\_\_\_\_ Body I.D. (D): \_\_\_\_\_

## Materials of Construction

\* Pipe Material  Carbon Steel  304 SST  316 SST  Hastelloy  Other \_\_\_\_\_

\* Primary Element Material  316 SST  Hastelloy  Other \_\_\_\_\_ (Please verify material availability)

## Operating Conditions

	4 mA value	Minimum	Normal	Maximum	Full Scale: 20 mA flow rate (design to P and T)	Design
Flow Rate	0	*(1)	*	*		
Pressure (P)	—	*(1)	*	*(1)	*(2)	
Temperature (T)	—	*(1)	*	*(1)	*	

## RTD Mode

Normal Mode ★ (Requires a RTD to be connected. If the RTD is disconnected or fails, the 3095MV output goes to alarm value)

Fixed Temperature Mode: Specify the fixed temperature value \_\_\_\_\_  °F  °C

Backup Mode (Uses the connected RTD for temperature measurement. If the RTD is disconnected or fails, the transmitter uses a fixed temperature value as a backup. This will not cause the mA output to go to alarm value and can potentially cause inaccurate flow measurement.) Fixed temperature value to be used as backup \_\_\_\_\_  °F  °C



\* = Required Item  
★ = Default

**Base Conditions**

- Standard Base (P=14.696 psia / 101.325 kPa abs, T= 60 °F (15.56 °C))
  - Normal Base (P=14.696 psia / 101.325 kPa abs, T= 32 °F (0 °C))
  - Standard Base for Natural Gas (AGA) (P=14.73 psia, T= 60°F (15.56 °C))
  - User Defined: P= \_\_\_\_\_ Units: \_\_\_\_\_ T= \_\_\_\_\_ Units = \_\_\_\_\_
- Compressibility at Base: \_\_\_\_\_ OR Density at Base: \_\_\_\_\_

(1) Operating ranges for pressure and temperature are needed for transmitter configuration.

(2) Required to verify that the product selection meets design criteria.

**TABLE 26. Rosemount Fluids Database<sup>(1)</sup>**

Acetic Acid	Divinyl Ether	Methane	n-Hexane	1-Heptanol
Acetone	Ethane	Methanol	n-Octane	1-Heptene
Acetonitrile	Ethanol	Methyl Acrylate	n-Pentane	1-Hexene
Acetylene	Ethylamine	Methyl Ethyl Ketone	Oxygen	1-Hexadecanol
Acrylonitrile	Ethylbenzene	Methyl Vinyl Ether	Pentafluorothane	1-Octanol
Air	Ethylene	m-Chloronitrobenzene	Phenol	1-Octene
Allyl Alcohol	Ethylene Glycol	Neon	Propadiene	1-Nonanol
Ammonia	Ethylene Oxide	Neopentane	Pyrene	1-Pentadecanol
Argon	Fluorene	Nitric Acid	Propylene	1-Pentanol
Benzene	Furan	Nitric Oxide	Styrene	1-Pentene
Benzaldehyde	Helium-4	Nitrobenzene	Sulfur Dioxide	1-Undecanol
Benzyl Alcohol	Hydrazine	m-Dichlorobenzene	Propane	1-Nonanal
Biphenyl	Hydrogen	Nitroethane	Toluene	1,2,4- Trichlorobenzene
Carbon Dioxide	Hydrogen Chloride	Nitrogen	Trichloroethylene	1,1,2- Trichloroethane
Carbon Monoxide	Hydrogen Cyanide	Nitromethane	Vinyl Acetate	1,1,2,2- Tetrafluoroethane
Carbon Tetrachloride	Hydrogen Peroxide	Nitrous Oxide	Vinyl Chloride	1,2-Butadiene
Chlorine	Hydrogen Sulfide	n-Butane	Vinyl Cyclohexane	1,3-Butadiene
Chlorotrifluoroethylene	Isobutane	n-Butanol	Water	1,3,5- Trichlorobenzene
Chloroprene	Isobutene	n-Butyraldehyde	1-Butene	1,4-Dioxane
Cycloheptane	Isobutyl benzene	n-Butyronitrile	1-Decene	1,4-Hexadiene
Cyclohexane	Isopentane	n-Decane	1-Decanal	2-Methyl-1-Pentene
Cyclopentane	Isoprene	n-Dodecane	1-Decanol	2,2-Dimethylbutane
Cyclopentene	Isopropanol	n-Heptadecane	1-Dodecene	
Cyclopropane		n-Heptane	1-Dodecanol	

(1) This list is subject to change without notice. Steam per ASME Steam tables. All other fluids per AIChE.

**Block Tag Names**

- AI Block Name (Flow): \_\_\_\_\_ (AI 1400 ★)
- AI Block Name (DP): \_\_\_\_\_ (AI 1500 ★)
- AI Block Name (SP): \_\_\_\_\_ (AI 1600 ★)
- AI Block Name (PT): \_\_\_\_\_ (AI 1700 ★)
- INTEG Block Name (Flow Total): \_\_\_\_\_ (INTEG 2100 ★)

**Drawing/Notes**

## Fluid Data Sheet (FDS)

For custom fluid not in the Rosemount Fluid Database

For technical assistance in filling out this CDS, call an Emerson Process Management representative. Complete this form to define a custom fluid. The H symbol identifies the default value.

### NOTE

This form is not required if using the Rosemount Fluid Database.

\* = Required Item

★ = Default

#### Customer Information

Customer:	Contact Name:
Customer Phone:	Customer Fax:
	Customer PO:

#### Fluid Properties

<input type="checkbox"/> Custom Liquid– Complete Table	<input type="checkbox"/> Liquid
<input type="checkbox"/> Custom Gas– Complete Table	<input type="checkbox"/> Gas
<input type="checkbox"/> Custom Natural Gas– Complete Table	<input type="checkbox"/> Natural Gas

#### For Rosemount Use Only

S.O.:	LI
CHAMP:	DATE:
	ADMIN:

**TABLE 27. Custom Liquid Worksheet**

\* = Required Item

★ = Default

**Mass Liquid Density and Viscosity Information**

1. Fill in the following operating temperatures

- a) \_\_\_\_\_ min
- b) \_\_\_\_\_ [ $^{1/3}(\text{max} - \text{min})$ ] + min
- c) \_\_\_\_\_ [ $^{2/3}(\text{max} - \text{min})$ ] + min
- d) \_\_\_\_\_ max

2. Transfer the values from the above section to the numbered lines below.

3. Check one Density box, then enter the values for each temperature and the standard density.

4. Check one Viscosity box, then enter values for each temperature. (At least one viscosity value is required).

Density

- Density in lbs/CuFt
- Density in kg/CuM

Viscosity

- Viscosity in centipoise
- Viscosity in lbs/ft sec
- Viscosity in pascal sec

Temperature

- a) \_\_\_\_\_ min
- b) \_\_\_\_\_ [ $^{1/3}(\text{max} - \text{min})$ ] + min
- c) \_\_\_\_\_ [ $^{2/3}(\text{max} - \text{min})$ ] + min
- d) \_\_\_\_\_ max

Temperature

- a) \_\_\_\_\_ min.
- b) \_\_\_\_\_ [ $^{1/3}(\text{max} - \text{min})$ ] + min
- c) \_\_\_\_\_ [ $^{2/3}(\text{max} - \text{min})$ ] + min
- d) \_\_\_\_\_ max

Base density: \_\_\_\_\_  
 (at base reference conditions specified)

**Volumetric Liquid Density and Viscosity Information**

\* Density at Flow: \_\_\_\_\_ Units:  lb/ft<sup>3</sup>  Kg/m<sup>3</sup>  Other:

OR

Specific Gravity at Flow: \_\_\_\_\_

\* Viscosity at Flow: \_\_\_\_\_ Units:  Centipoise  Other:

# Rosemount Compact Orifice Flowmeter Series

**Product Data Sheet**  
00813-0100-4810, Rev FA  
August 2006

**TABLE 28. Custom Gas Worksheet**

\* = Required Item

★ = Default

**Mass Gas Compressibility and Viscosity Information**

1. Fill in the following operating pressures and operating temperatures

Operating Pressures

- 1) \_\_\_\_\_ min
- 2) \_\_\_\_\_ [ $^{1/3}$  (max - min))] + min
- 3) \_\_\_\_\_ [ $^{2/3}$  (max - min))] + min
- 4) \_\_\_\_\_ max

Operating Temperatures

- 5) \_\_\_\_\_ min
- 6) \_\_\_\_\_ [ $^{1/2}$  (max - min))] + min
- 7) \_\_\_\_\_ max
- 8) \_\_\_\_\_ [ $^{1/3}$  (max - min))] + min
- 9) \_\_\_\_\_ [ $^{2/3}$  (max - min))] + min

**2. Transfer the values from the above section to the numbered lines below**

- 3. Check one Density/Compressibility box, then enter the 12 values for each pressure/temperature range.
- 4. Check one Viscosity box, then enter values for each temperature. (At least one viscosity value is required).
- 5. Enter values for molecular weight, isentropic exponent, and standard density (or standard compressibility).

Density

- Density in lbs/CuFt
- Density in kg/CuM
- Compressibility

Pressure

Temperature

- |          |          |
|----------|----------|
| 1) _____ | 5) _____ |
| 2) _____ | 5) _____ |
| 3) _____ | 5) _____ |
| 4) _____ | 5) _____ |
| 1) _____ | 6) _____ |
| 2) _____ | 6) _____ |
| 3) _____ | 6) _____ |
| 4) _____ | 6) _____ |
| 1) _____ | 7) _____ |
| 2) _____ | 7) _____ |
| 3) _____ | 7) _____ |
| 4) _____ | 7) _____ |

Viscosity

- Viscosity in centipoise
- Viscosity in lbs/ft sec
- Viscosity in pascal sec

Temperature

- 5) \_\_\_\_\_
- 8) \_\_\_\_\_
- 9) \_\_\_\_\_
- 7) \_\_\_\_\_

Molecular Weight: \_\_\_\_\_

Isentropic Exponent: \_\_\_\_\_ 1.4 ★

Standard density/compressibility: \_\_\_\_\_

**Volumetric Gas Compressibility and Viscosity Information**

\* Density at Flow: \_\_\_\_\_ Units:  lb/ft<sup>3</sup>  Kg/m<sup>3</sup>  Other:

OR

M.W. / Specific Gravity at Flow: \_\_\_\_\_

Compressibility at Flow: \_\_\_\_\_

Compressibility at Base: \_\_\_\_\_

\* Viscosity at Flow: \_\_\_\_\_ Units:  Centipoise  Other: Isentropic Exponent (K): \_\_\_\_\_ 1.4 ★

**TABLE 29. Natural Gas Worksheet**

**NOTE**

The minimum requirement for the Volumetric options is highlighted gray on page 45.

**Compressibility Factor Information**

Choose desired characterization method and only enter values for that method.

<input type="checkbox"/> Detail Characterization Method (AGA8 1992)		Mole	Valid Range
CH <sub>4</sub>	Methane mole percent _____	%	0 – 100 percent
N <sub>2</sub>	Nitrogen mole percent _____	%	0 – 100 percent
CO <sub>2</sub>	Carbon Dioxide mole percent _____	%	0 – 100 percent
C <sub>2</sub> H <sub>6</sub>	Ethane mole percent _____	%	0 – 100 percent
C <sub>3</sub> H <sub>8</sub>	Propane mole percent _____	%	0 – 12 percent
H <sub>2</sub> O	Water mole percent _____	%	0 – Dew point
H <sub>2</sub> S	Hydrogen Sulfide mole percent _____	%	0 – 100 percent
H <sub>2</sub>	Hydrogen mole percent _____	%	0 – 100 percent
CO	Carbon monoxide mole percent _____	%	0 – 3.0 percent
O <sub>2</sub>	Oxygen mole percent _____	%	0 – 21 percent
C <sub>4</sub> H <sub>10</sub>	i-Butane mole percent _____	%	0 – 6 percent <sup>(1)</sup>
C <sub>4</sub> H <sub>10</sub>	n-Butane mole percent _____	%	0 – 6 percent <sup>(1)</sup>
C <sub>5</sub> H <sub>12</sub>	i-Pentane mole percent _____	%	0 – 4 percent <sup>(2)</sup>
C <sub>5</sub> H <sub>12</sub>	n-Pentane mole percent _____	%	0 – 4 percent
C <sub>6</sub> H <sub>14</sub>	n-Hexane mole percent _____	%	0 – Dew Point
C <sub>7</sub> H <sub>18</sub>	n-Heptane mole percent _____	%	0 – Dew Point
C <sub>8</sub> H <sub>18</sub>	n-Octane mole percent _____	%	0 – Dew Point
C <sub>9</sub> H <sub>20</sub>	n-Nonane mole percent _____	%	0 – Dew Point
C <sub>10</sub> H <sub>22</sub>	n-Decane mole percent _____	%	0 – Dew Point
He	Helium mole percent _____	%	0 – 3.0percent
Ar	Argon mole percent _____	%	0 – 1.0 percent

<input type="checkbox"/> Gross Characterization Method, Option Code 1 (AGA8 Gr-Hv-CO <sub>2</sub> )		Mole	Valid Range
Specific Gravity at 14.73 psia and 60 °F _____			0.554 – 0.87
Volumetric gross heating value at base conditions _____		BTU/SCF	477 – 1150 BTU/SCF
Carbon Dioxide mole percent _____		%	0 – 30 percent
Hydrogen mole percent _____		%	0 – 10 percent
Carbon Monoxide mole percent _____		%	0 – 3.0 percent

<input type="checkbox"/> Gross Characterization Method, Option Code 2 (AGA8 Gr-CO <sub>2</sub> -N <sub>2</sub> )		Mole	Valid Range
Specific Gravity at 14.73 psia and 60 °F _____		%	0.554 – 0.87
Carbon Dioxide mole percent _____		%	0 – 30 percent
Nitrogen mole percent _____		%	0 – 50 percent
Hydrogen mole percent _____		%	0 – 10 percent
Carbon Monoxide mole percent _____		%	0 – 3.0 percent

(1) The summaries of i-Butane and n-Butane cannot exceed 6 percent.

(2) The summaries of i-Pentane and n-Pentane cannot exceed 4 percent.

# Rosemount Compact Orifice Flowmeter Series

**Product Data Sheet**  
00813-0100-4810, Rev FA  
August 2006

---

## Notes

**Notes**

# Rosemount Compact Orifice Flowmeter Series

---

**Product Data Sheet**  
00813-0100-4810, Rev FA  
August 2006

*Rosemount, the Rosemount logotype, ProPlate, Mass ProPlate, and Annubar are registered trademarks of Rosemount Inc.  
All other marks are the property of their respective owners.*

**Emerson Process Management  
Rosemount Inc.**

8200 Market Boulevard  
Chanhassen, MN USA 55317  
T (US) (800) 999-9307  
T (Intl) (952) 906-8888  
F (952) 949-7001

[www.rosemount.com](http://www.rosemount.com)

**Emerson Process Management**

Heath Place  
Bognor Regis  
West Sussex PO22 9SH  
England  
T 44 (0) 1243 863121  
F 44 (0) 1243 867554

**Emerson Process Management Asia  
Pacific Private Limited**

1 Pandan Crescent  
Singapore 128461  
T (65) 6777 8211  
F (65) 6777 0947  
[Enquiries@AP.EmersonProcess.com](mailto:Enquiries@AP.EmersonProcess.com)

