

Rosemount 2120 Vibrating Fork Liquid Level Switch

- Function virtually unaffected by flow, bubbles, turbulence, foam, vibration, solids content, coating, properties of the liquid, and product variations
- No need for calibration and requires minimum installation procedures
- Easy terminal access, polarity insensitive and short circuit protection
- No moving parts or crevices means virtually no maintenance
- Electronic, self-checking and condition monitoring - Heartbeat LED gives status and health information
- Adjustable Switching Delay for turbulent/splashing applications
- Magnetic test point makes functional test easy
- Small in size and weight
- "Fast Drip" Fork Design gives quicker response time especially with viscous liquids
- Explosion/Flameproof and Intrinsically Safe options
- SIL 2 of IEC 61508
- DIBt/WHG overflow protection



COMING SOON

Rosemount 2130 High Temperature Vibrating Fork Level Switch

- Enhanced diagnostics features improved self-checking and fault monitoring
- DPDT/DPCO relay output cassette
- 8...16 mA output cassette
- AS-i Bus output cassette

Consult factory for availability.



Contents

Measurement Principle	page Level-2
Special Features	page Level-2
Rosemount 2120 Application Examples	page Level-3
Select Rosemount 2120 Vibrating Fork Liquid Level Switch	page Level-4
Application and Installation Best Practices	page Level-5
Specifications	page Level-6
Product Certifications	page Level-8
Dimensional Drawings	page Level-10
Ordering Information	page Level-13

Superior Reliability in a Universal Package

The Rosemount 2120 is a liquid point level switch based on the vibrating short fork technology making it suitable for virtually all liquid applications. Complete range of process connections, wide choice of housing and wetted parts materials, four different switching functions, extended fork lengths, hazardous area and overfill approvals make it configurable to almost all requirements.

MEASUREMENT PRINCIPLE

The Rosemount 2120 is a liquid point level switch designed using the principle of a tuning fork. A piezo-electric crystal is used to oscillate the forks at their natural frequency. Changes to this frequency are continuously monitored. When the 2120 is used as a low alarm, the liquid in the vessel drains down past the fork, resulting in a change of natural frequency; this is detected by the electronics which switch the output state. When used as a high alarm, the liquid rises in the vessel, makes contact with the fork and again the output switches.

Short Fork Technology

The natural frequency (~1300Hz) of the fork has been chosen to avoid interference from plant vibration which may cause false switching. This allows for minimum intrusion into the vessel or pipe through the use of a short fork. Using Short Fork Technology, the Rosemount 2120 is designed for use in virtually all liquid applications. Extensive research has maximized the operational effectiveness of the fork design making it suitable for almost all liquids, including coating liquids (avoid bridging of forks), aerated liquids, and slurries.

SPECIAL FEATURES

Mode Switch/Adjustable Time Delay

A mode switch allows the 2120 to be set to switch from wet to dry (typically low alarm) or from dry to wet (typically high alarm). There is also a user selectable time delay from 0.3, 1, 3, 10, or 30 seconds. Increasing the time delay in turbulent or splashing applications virtually eliminates the risk of false switching.

Heartbeat LED

The Rosemount 2120 has a status indicating heartbeat LED which can be seen at all times and from all angles through a lens in the cover (no lens in metal housings). The LED will flash when the 2120 is 'off' and will be constantly lit when it is 'on'. The LED gives constant indication that the 2120 is functioning correctly (different flash rates are used to indicate product malfunction) and gives local indication of the process state.

Magnetic Test Point

A magnetic test point is located on the side of the housing, allowing the user to perform a functional test of the 2120 and the system connected to it. By holding a magnet to the target, the 2120 output will change state for as long as the magnet is held.

Electrical Hookup

The terminal blocks extend above the housing and give easy terminal access. The polarity insensitivity and short circuit protection make electrical hook-up safe and easy.

Fork Design

The "fast drip" fork design (liquid is drawn away from the fork tips) together with a short switching delay allow the 2120 to react more quickly and have greater sensitivity to density variations.

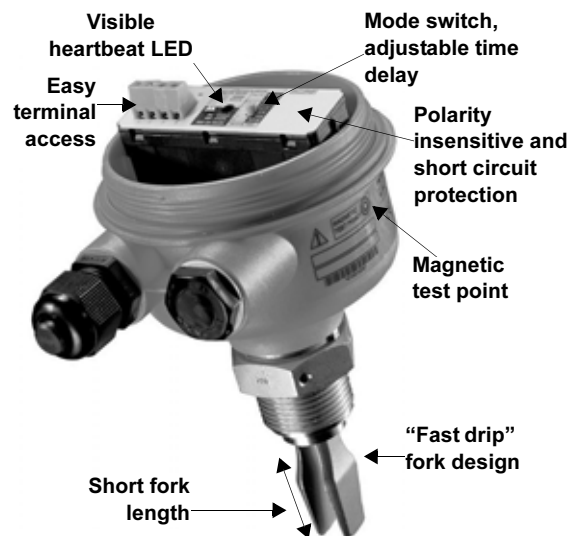

ROSEMOUNT 2120 APPLICATION EXAMPLES



- High integrity
- Manual test facility
- Heartbeat LED

Overfill Protection

Spillage caused by overfilling can be hazardous to people and the environment, resulting in lost product and potentially high clean up costs. The 2120 is a limit level switch used to signal overfill at any time. The 2120 is available with DIBt/WHG overfill protection approval.

- Time delay switching option
- Resistance to false switching
- Choice of electronic outputs



Limit Detection

Batch processing tanks often contain stirrers/agitators to ensure mixing and product 'fluidity'. The standard user selectable time delay ranging from 0.3 to 30 seconds virtually eliminates the risk of false switching due to splashing caused by stirrers/agitators.



- Small forks
- Low cost
- Reliable
- IP66/67, Type 4X

Pipe Installation (Pump Protection)

Short forks mean minimum intrusion wetside and allow simple low cost installation at any angle into your pipes or vessels. With the fork projecting only 2-in. (50 mm) (dependant on connection type), the 2120 can be installed in even small diameter pipes. By selecting the option of direct load switching electronics, the 2120 is ideal for reliable pump control and can be used to protect against pumps running dry.

- Range of process connections
- High temperature
- High pressure
- Plastic, SST, or aluminum housing

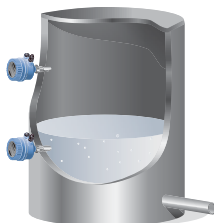

High and Low Level Alarm

Maximum and minimum level detection in tanks containing many different types of liquids are ideal applications for the 2120. The robust 2120 operates continuously at temperatures up to 302°F (150°C) and operating pressures up to 1450 psig (100 barg) making it perfect for use as a high or low level alarm. It is common practice to fit an independent high level alarm switch as a backup device to any other level device installed in case of primary device failure.

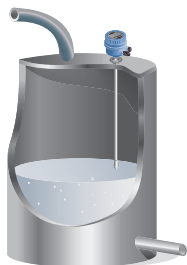

- Hygienic surface finish
- Extended fork
- Install anywhere

Hygienic Applications

With the option of highly polished forks providing a surface finish (Ra) better than 0.8µm, the 2120 meets the principle design criteria of the most stringent hygienic requirements used in food and beverage, and pharmaceutical applications. Manufactured in stainless steel the 2120 is robust enough to easily withstand steam cleaning (CIP) routines at temperatures up to 302°F (150°C).

SELECT ROSEMOUNT 2120 VIBRATING FORK LIQUID LEVEL SWITCH

The Rosemount 2120 switch consists of housing, tank connection, and forks. The tank connection and forks are the only wetted parts.



Switch Housing

The switch housing is available in glass filled nylon, aluminum or SST with two M20, 1/2-in., or 3/4-in. NPT cable/conduit entries. It can be ordered with Intrinsically Safe or Explosion Proof / Flame Proof approvals. Approval depends on the housing type, see Product Certifications on page 14.

Electronics

Standard two core cable can be used with any power supply from 20 to 264V ac (50/60 Hz) or 20 to 60V dc to connect the 2120 in series with a load to achieve direct load switching. The output acts as a simple SPST switch that changes state with liquid presence. Alternatively the switching function of the SPCO relay electronics output can be used. The 2120 also has the option of electronics that can be interfaced directly to a PLC using the PNP transistor output model (three-wire). The Intrinsically Safe (IS) 2120 to ATEX EEx ia approval interfaces directly with standard NAMUR (DIN 19234, IEC60947-5-6, EN50227) isolation amplifiers.

Tank Connection and Fork

Fork Length

Short fork for minimum intrusion installation (minimum 2-in. [50 mm]) or fork extensions up to 118-in. (3m) are available. See "Dimensional Drawings" on page 10.

Threaded Connection

Threads: R 3/4-in. and 1-in. (BSPT); G 3/4-in. and 1-in. (BSPP); 3/4-in. and 1-in. NPT

Material: 316L SST, Hastelloy C

Accessories: A stainless steel adjustable clamp gland is available for use with extended length 2120 (1-in. models only). This is threaded 1 1/2-in. BSPP for connection to the vessel, and allows the 1-in. extended length 2120 to be raised or lowered as desired then clamped in position. See Spare Parts and Accessories on page 16.

Flanged Connections

Flange: ANSI B16.5 (1.5-in. or larger), BS4504 (DN40 or larger)

Material: 316L SST, Halar/PFA coated, other on request

Hygienic Connections

Fittings: 1.5-in. (38 mm) or 2-in. (51 mm) Tri-Clamp, 1-in. BSPP (G) O-ring seal, or other on request

Material: 316L SST

Options: Hand polished wetside to a finish better than 0.8µm meets the principle design criteria of the most stringent hygienic requirements.

Accessories: A mounting kit comprising vessel fitting, Nitrile seal and clamp ring is available for use with 2-in. (51 mm) Tri-Clamp 2120. A fitting boss with Fluorocarbon (FPM/FKM) O-ring is available for use with O-ring seal 2120. See Spare Parts and Accessories on page 16.

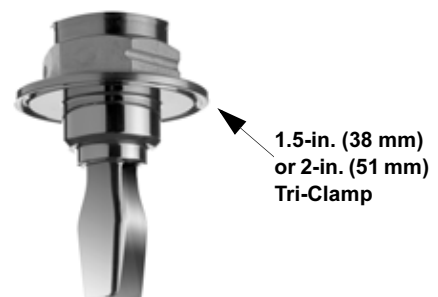

APPLICATION AND INSTALLATION BEST PRACTICES

Application Considerations:

- Ensure liquid is inside the temperature and pressure ranges (see specifications).
- Check that the liquid is inside recommended viscosity range 0.2 to 10,000 cP.
 - Examples of products that are too viscous are chocolate syrup, ketchup, peanut butter and bitumen.
 - The switch will still detect products above 10,000 cP, however, the drain times become prohibitively long or cleaning may become necessary to resume dry functioning.
- Check that the liquid density is above 37.5 lb/ft³ (600 kg/m³).
 - Examples of products with densities too low are propane and propylene.
- Check for risk of build-up on the forks.
 - Avoid situations where drying and coating products may create excessive build-up.
 - Ensure there is no risk of bridging the forks.
 - If coating or bridging may occur, ensure the Halar/PFA coated version is used to reduce the risk of build-up.
 - Examples of products that can create bridging of forks are dense paper slurries and bitumen.
- Check the solids content in the liquid.
 - Problems may occur if product coats and dries causing caking.
 - As a guideline maximum solid particle diameter in the liquid is 0.2-in. (5 mm).
 - Extra consideration is needed when dealing with particles bigger than 0.2-in. (5 mm), consult factory.
- Foam
 - In almost all cases the 2120 is insensitive to foams (does not see the foam).
 - However in rare occasions some very dense foams may be seen as liquid, known example of this is found in ice-cream and orange juice manufacturing.

Recommended Installation:

- Always install in the normally “on” state.
 - For high level is Dry on.
 - For low level is Wet on.
- Always ensure the system is tested by using the local magnetic test point during commissioning.
- Ensure sufficient room for mounting and electrical connection (See page Level-10 for switch dimensions).
- Avoid installing the 2120 where it will be exposed to liquid entering the tank at the fill point.
- Avoid heavy splashing on the forks.
 - Raising the time delay reduces accidental switching caused by splashing.
- Ensure that the forks do not come into contact with the tank wall or any internal fittings or obstructions.
- Ensure there is sufficient distance between build-up on the tank wall and the fork.

FIGURE 1. Example of OK and not OK build-up on tank wall.

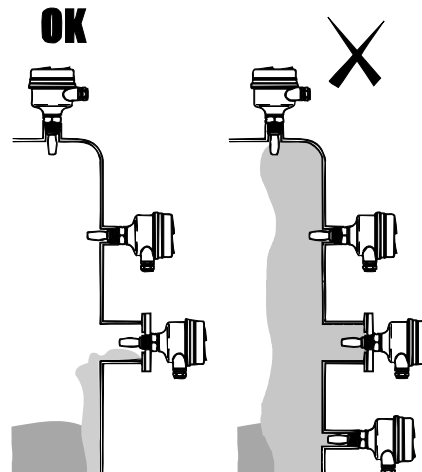

2120/fig9.eps

Specifications

Physical

Product

Rosemount 2120 Vibrating Fork Liquid Level Switch

Measuring principle

Vibrating Fork

Applications

Most liquids including coating liquids, aerated liquids, and slurries

Mechanical

Housing/Enclosure

Housing Code	A	D	X	Y	S	T
Housing material	Nylon PA66 30%GF		Al alloy ASTM B26 356-T6 or LM25 TF		316C12 Stainless Steel	
LED Window	PMMA		none		none	
Conduit Entry	M20	1/2-in. NPT	M20	3/4-in. NPT	M20	3/4-in. NPT
Ingress Protection	IP66/67 to EN60529		IP66/67 to EN60529, Type 4X		IP66/67 to EN60529, Type 4X	

Connections

See Process Connection Size / Type on page 13.

Extended Lengths

Available as standard to a maximum of 118-in. (3000 mm), other on request

Process Material

316L Stainless Steel (1.4404), Hastelloy C or Halar (ECTFE) / PFA co-polymer coating (39.37-in. [1000 mm] max). Hand polished to better than 0.8µm option available for hygienic connections. Gasket material for 3/4 in. and 1 in. BSPP (G) is Non-asbestos BS7531 Grade X carbon fiber with rubber binder.

Dimensional Drawings

See "Dimensional Drawings" on page 10

Performance

Hysteresis (water)

±0.039-in. (± 1mm) nom.

Switching Point (water)

0.5-in. (13 mm) from tip (vertical) / from edge (horizontal) of fork (this will vary with different liquid densities).

Functional

Maximum Operating Pressure

Final rating depends on tank connection

Threaded Connection

See Figure 2.

Note: Clamp gland (02120-2000-0001), see page Level-16, limits the maximum operating pressure to 18.85 psig (1.3 barg).

Hygienic Connection

435 psig (30 barg)

Flanged Connection

See Figure 2 and Table 1 (whichever one is lower).

FIGURE 2. Process Pressure

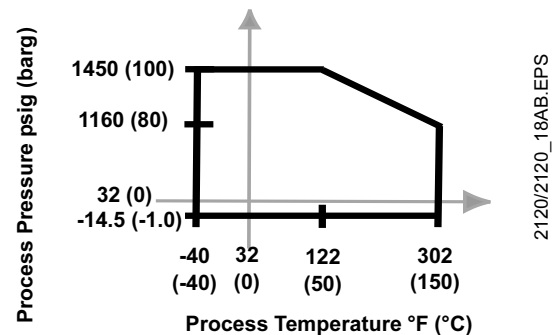

TABLE 1. Maximum Flange Pressure Rating

Standard	Class/Rating	SST Flanges
ANSI	150 lb.	275 psig ⁽¹⁾
ANSI	300 lb.	720 psig ⁽¹⁾
ANSI	600 lb.	1,440 psig ⁽¹⁾
DIN	PN 10/16	10/16 barg ⁽²⁾
DIN	PN 25/40	25/40 barg ⁽²⁾
DIN	PN 64	64 barg ⁽²⁾
DIN	PN 100	100 barg ⁽²⁾

(1) At 100°F (38°C), the rating decreases with increasing temp.

(2) At 248°F (120°C), the rating decreases with increasing temp.

Temperature

See Figure 3.

FIGURE 3. Temperature

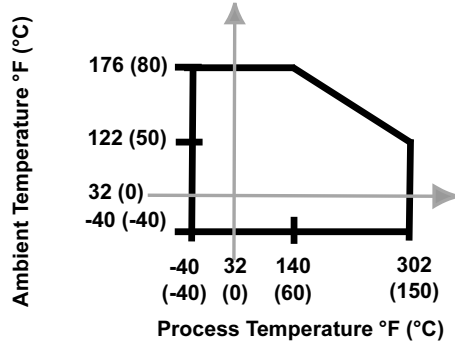

2120/2120_18AC.EPS

Liquid Density Range

Minimum 37.5 lb/ft³ (600 kg/m³)

Liquid Viscosity Range

0.2 to 10,000 cP (centiPose)

Solids Content and Coating

Maximum recommended diameter of solid particles in the liquid is 0.2-in. (5 mm).

For coating product, avoid bridging of forks.

Switching Delay

User selectable 0.3, 1, 3, 10, 30 seconds delay dry to wet/wet to dry

CIP (Clean In Place) Cleaning

Withstands steam cleaning routines up to 302°F (150°C)

Electrical

Switching Mode

User selectable (Dry = on or Wet = on)

Protection

Polarity insensitive. Over-current, short-circuit and load-missing protection. Surge protection to IEC61326.

Terminal Connection (wire diameter)

Max. 0.1-in² (2.5 mm²) (Note national regulations)

Conduit Plugs/Cable Gland

- Metal Ex d Housing: Conduit entries for explosion proof areas are shipped with two brass conduit plugs.
- Plastic housing with direct load, PNP/PLC and IS electronics are shipped with one PA66⁽¹⁾ cable gland and one blanking plug.
- Plastic housing with relay electronics are shipped with two PA66⁽¹⁾ cable glands.

(1) Cable diameter 0.2 to 0.3-in. (5 to 8 mm)

Grounding

The 2120 should always be grounded either through the terminals or using the external ground connection provided.

Electrical Connections

- Direct load switching (two-wire)

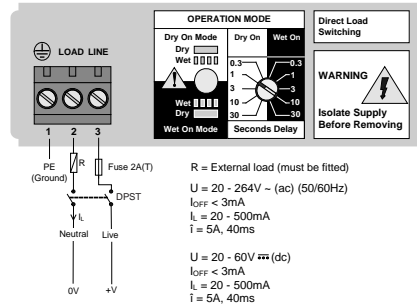

- Solid state PNP output for direct interface to PLC's (three wire)

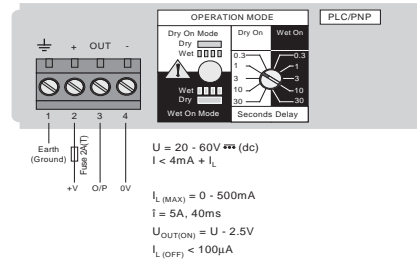

- SPCO single relay for voltage free contacts

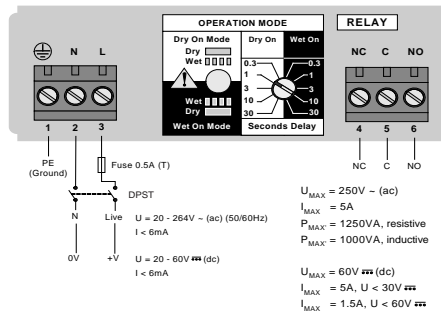

- Intrinsically Safe (IS) NAMUR to DIN 19234, IEC 60947-5-6

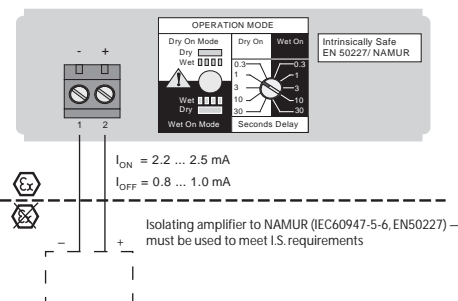

Product Certifications

ORDINARY LOCATION CERTIFICATION FOR FM

G5 Project ID: 3024095
The switch has been examined and tested to determine that the design meets basic electrical, mechanical, and fire protection requirements by FM, a nationally recognized testing laboratory (NRTL) as accredited by the Federal Occupational Safety and Health Administration (OSHA).

ORDINARY LOCATION CERTIFICATION FOR CSA

G6 Certificate Number: 06 CSA 1796535
The switch has been examined and tested to determine that the design meets basic electrical, mechanical, and fire protection requirements by CSA, a nationally recognized testing laboratory as accredited by the Standards Council of Canada (SCC).

EUROPEAN DIRECTIVE INFORMATION

The EC declaration of conformity for all applicable European directives for this product can be found on the Rosemount website at www.rosemount.com. A hard copy may be obtained by contacting your local sales office.

ATEX Directive (94/9/EC)

Complies with the ATEX Directive.

Pressure Equipment Directive (PED) (97/23/EC)

2120 is outside the scope of PED Directive.

L.V. Directive

EN61010-1 Pollution degree 2, Category II (264V max), Pollution degree 2, Category III (150V max)

Electro Magnetic Compatibility (EMC) Directive

EN61326 Emissions to Class B.

Immunity to industrial location requirements.

Vibration Resistance

EN60721 level 3M6/4M6

CE-mark

Complies with applicable directives (EMC, ATEX, LVD)

Overfill Protection

Option available for DIBt/WHG

SIL Declaration of Conformity

Rosemount 2120 IS Namur Vibrating Fork Level Sensor Models 2120***C*** has demonstrated proven reliability. It is manufactured and supported in a manner suitable for applications up to SIL 2 of IEC 61508 as a Type B Safety Related Subsystem when configured as a high level alarm⁽¹⁾ in conjunction with a Namur Barrier⁽¹⁾.

HAZARDOUS LOCATIONS CERTIFICATIONS

North American Approvals

Factory Mutual (FM) Explosion Proof Approval

E5 Project ID: 3024095
Explosion Proof for Class I, Div. 1, Groups A, B, C and D
Temperature Class:
T6 (T_{amb} -40°C to +75°C)

Enclosure: Type 4X

Factory Mutual (FM) Intrinsically Safe Approval

I5 Project ID: 3024095
Intrinsically Safe for Class I, Div. 1, Groups A, B, C and D
Class I, Zone 0, AEx ia IIC
Temperature Code:
T5 (T_{amb} -40°C to +80°C, T_{proc} < 80°C)

Control Drawing: 71097/1154

Ui=15 V, Ii=32 mA, Pi=0.1 W, Ci=211 nF, Li=0.06 mH

NOTE

A NAMUR isolating amplifier must be used for intrinsic safety.

Canadian Approvals

Canadian Standards Association (CSA) Explosion Proof Approvals

E6 Project ID: 1796535
Explosion Proof for Class I, Div. 1, Groups A, B, C, and D
Temperature Class:
T6 (T_{amb} -40°C to +75°C)

Enclosure: Type 4X

Canadian Standards Association (CSA) Intrinsically Safe Approval

I6 Certificate Number: 06 CSA 1796535
Intrinsically Safe for Class I, Div. 1, Groups A, B, C, and D
Class 1, Zone 0, Ex ia IIC
Temperature Code:
T5 (T_{amb} -40°C to +80°C, T_{proc} < 80°C)

Control Drawing: 71097/1179

Ui=15 V, Ii=32 mA, Pi=0.1 W, Ci=211 nF, Li=0.06 mH

(1) Refer to manual for IEC 61508 configuration details.

Product Data Sheet

00813-0100-4030, Rev DB
Catalog 2008 - 2009

Rosemount 2120

Canadian Standards Association (CSA) Non-Incendive Approval

- I6** Certificate Number: 06 CSA 1796535
Non-Incendive for Class I, Div. 2, Groups A, B, C, and D
Temperature Code:
T5 (T_{amb} -40°C to +80°C, T_{proc} < 80°C)
- Control Drawing: 71097/1187
Ui=15 V, Ii=32 mA, Pi=0.1 W, Ci=211 nF, Li=0.06 mH

NOTE

A NAMUR isolating amplifier must be used for intrinsic safety.

European Approvals

ATEX Flameproof Approval

- E1** Certificate: Sira 05ATEX1129
Flame Proof:
ATEX Marking  II 1/2 G D
EEx d IIC T6 (T_{amb} -40°C to +75°C)

ATEX Intrinsically Safe Approval

- I1** Certificate: Sira 05ATEX2130X
Intrinsic Safety:
ATEX Marking  II 1 G D
EEx ia IIC T5 (T_{amb} -40°C to +80°C)
Ui=15 V, Ii=32 mA, Pi=0.1 W, Ci=12 nF, Li=0.06 mH

NOTE

A NAMUR isolating amplifier must be used for intrinsic safety.

International Approvals

National Supervision and Inspection Centre for Explosion Protection and Safety Instrumentation (NEPSI) Intrinsically Safe Approval

- I3** Certificates:
GYJ06530 (when manufactured in Slough, UK)
GYJ06531 (when manufactured in Singapore, Singapore)
Intrinsic Safety:
Ex ia IIC T5 (T_{amb} -40°C to +60°C)
Ui=15 V, Ii=32 mA, Pi=0.1 W, Ci=12 nF, Li=0.06 mH

NOTE

A NAMUR isolating amplifier must be used for intrinsic safety.

International Electrotechnical Commission (IEC) Flame Proof Approval

- E7** Certificate: IECEx SIR 06.0051
Flame Proof and Dust:
Zone 0/1
Ex d IIC T6 (T_{amb} -40°C to +75°C)
Ex tD A21 T85°C (T_{amb} -40°C to +75°C) IP6X

International Electrotechnical Commission (IEC) Intrinsically Safe Approval

- I7** Certificate: IECEx SIR 06.0070X
Intrinsically Safe and Dust:
Ex ia IIC T5, Ex iaD 20 T85 (T_{amb} -40°C to +80°C)
Ui=15 V, Ii=32 mA, Pi=0.1 W, Ci=12 nF, Li=0.06 mH

NOTE

A NAMUR isolating amplifier must be used for intrinsic safety.

Dimensional Drawings

Threaded Mounting

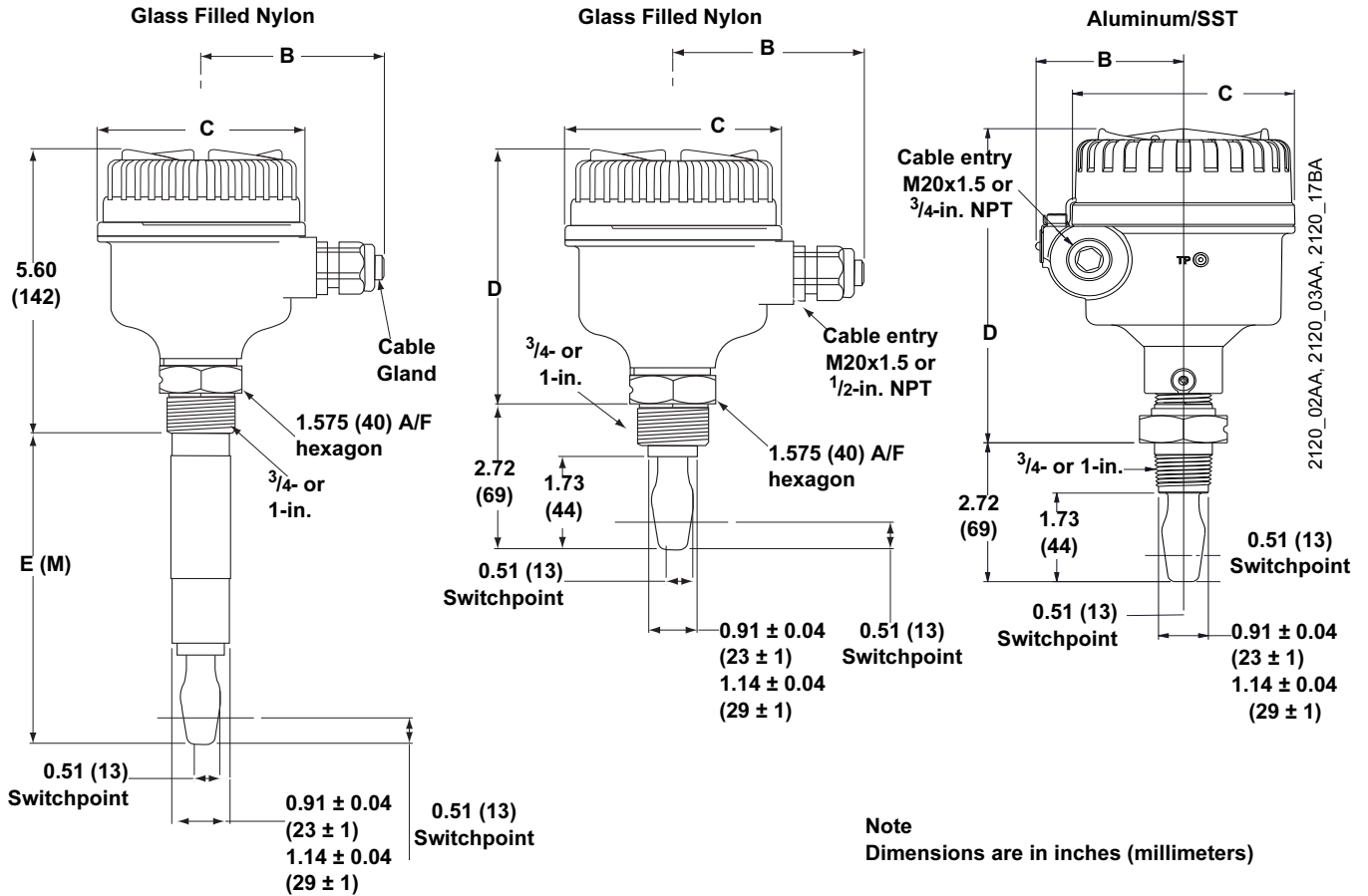

TABLE 2. Fork Length. Dimensions are in inches (millimeters)

Thread	Standard Length Model Code A	Minimum Length Model Code E (M)	Maximum Length Model Code E (M)
3/4-in.	1.73 (44)	3.74(95)	118.11 (3000)
1-in.	1.73 (44)	3.70 (94)	118.11 (3000)

TABLE 3. Housing Dimensions. Dimensions are in inches (millimeters)

Material	B	C	D
Glass Nylon	3.52 (90)	4.02 (102)	4.72 (120)
Aluminum	2.68 (68)	4.02 (102)	6.14 (156)
316 Stainless Steel	2.76 (70)	4.13 (105)	6.30 (160)

Flange Mounting

(Glass filled nylon housing shown)

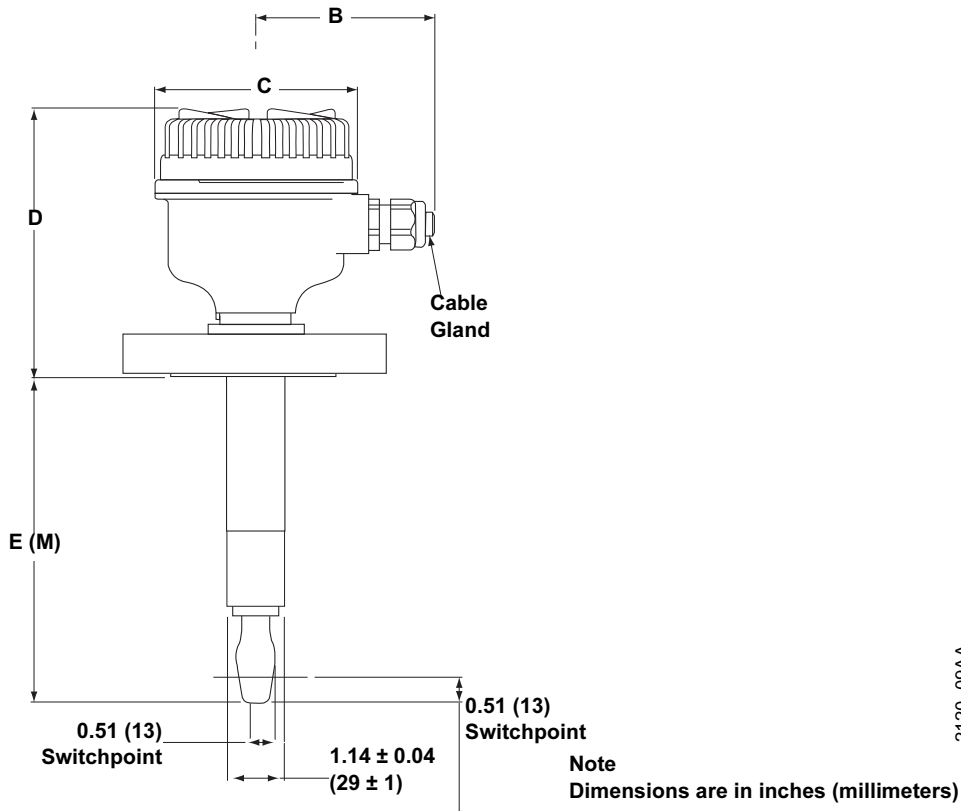

TABLE 4. Dimensions are in inches (millimeters)

Material	Standard Length Model Code H	Minimum Length Model Code E (M)	Maximum Length Model Code E (M)
Stainless Steel	4 (102)	3.50 (89)	118.11 (3000)
Halar/PFA co-polymer coated	4 (102)	3.50 (89)	39.37 (1000)

TABLE 5. Housing Dimensions. Dimensions are in inches (millimeters)

Material	B	C	D ⁽¹⁾
Glass Nylon	3.52 (90)	4.02 (102)	6.30 (160)
Aluminum	2.68 (68)	4.02 (102)	6.14 (156)
Stainless Steel	2.76 (70)	4.13 (105)	7.87 (200)

(1) Will vary with flange rating and thickness. "D" is nominal maximum thickness and allows a flange up to 1.77-in. (45 mm) thick. This equates to a 4-in. ANSI, 600lb. RF.

Hygienic Fitting

(Glass filled nylon housing shown)

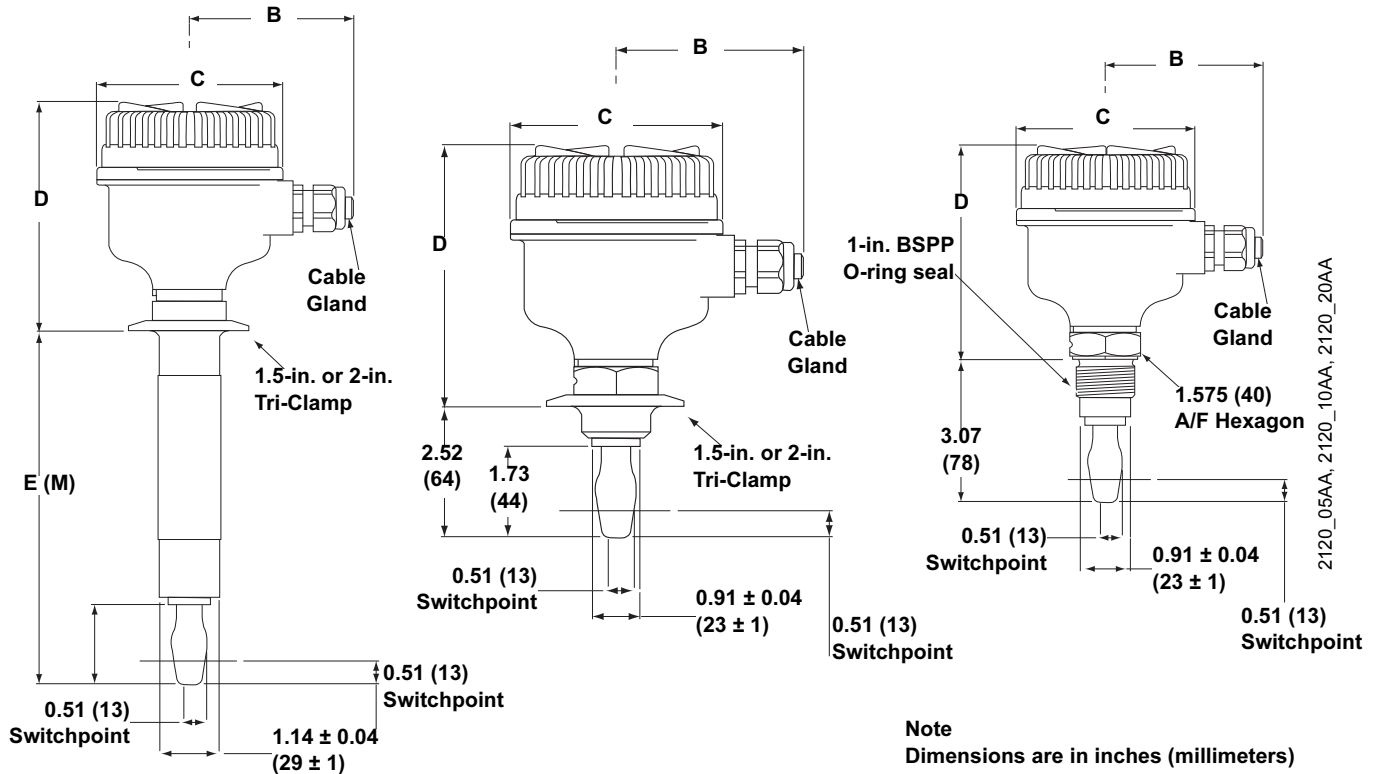

TABLE 6. Dimensions are in inches (millimeters)

Connection	Standard Length Model Code A	Minimum Length Model Code E (M)	Maximum Length Model Code E (M)
Tri-Clamp	1.7 (44)	4.13 (105)	118.11 (3000)
O-ring Seal (1-in. BSPP)	1.7 (44)	NA	NA

TABLE 7.

Material	B	C	D
Glass Nylon	3.52 (90)	4.02 (102)	4.96 (126)
Aluminum	2.68 (68)	4.02 (102)	6.14 (156)
Stainless Steel	2.76 (70)	4.13 (105)	6.54 (166)

Ordering Information

Model	Product Description
2120	Vibrating Fork Liquid Level Switch
Code	Material of Construction: Process Connection/Fork
D	316L Stainless Steel (1.4404)
N ⁽¹⁾⁽²⁾	316L SST (1.4404) with NACE compliance to MR 0175:2003 (ISO 15156:2003), MR 0103-2003
F ⁽³⁾	Halar/PFA, coated 316L SST (1.4404)
C ⁽⁴⁾	Hastelloy C, solid Hastelloy
Code	Process Connection Size / Type
Threaded	
0A	3/4-in. BSPT (R) thread
0B	3/4-in. BSPP (G) thread
0D	3/4-in. NPT thread
1A	1-in. BSPT (R) thread
1B	1-in. BSPP (G) thread
1D	1-in. NPT thread
Hygienic fitting	
1P	1-in. BSPP (G), O-ring
5R	1.5-in. (38 mm) Tri-Clamp
2R	2-in. (51 mm) Tri-Clamp
ANSI Flanges	
5G	1.5-in. ANSI, 150 lb. RF
5H	1.5-in. ANSI, 300 lb. RF
5J	1.5-in. ANSI, 600 lb. RF
2G	2-in. ANSI, 150 lb. RF
2H	2-in. ANSI, 300 lb. RF
2J	2-in. ANSI, 600 lb. RF
3G	3-in. ANSI, 150 lb. RF
3H	3-in. ANSI, 300 lb. RF
3J	3-in. ANSI, 600 lb. RF
4G	4-in. ANSI, 150 lb. RF
4H	4-in. ANSI, 300 lb. RF
4J	4-in. ANSI, 600 lb. RF
DIN (EN) Flanges	
5K	DN40, PN 10/16
5L	DN40, PN 25/40
5M	DN40, PN 64
5N	DN40, PN 100
2K	DN50, PN 10/16
2L	DN50, PN 25/40
2M	DN50, PN 64
2N	DN50, PN 100
7K	DN65, PN 10/16
7L	DN65, PN 25/40
7M	DN65, PN 64
7N	DN65, PN 100
3K	DN80, PN 10/16
3L	DN80, PN 25/40
3M	DN80, PN 64
3N	DN80, PN 100
4K	DN100, PN 10/16

Rosemount 2120

Product Data Sheet

00813-0100-4030, Rev DB

Catalog 2008 - 2009

4L	DN100, PN 25/40		
4M	DN100, PN 64		
4N	DN100, PN 100		
Other Process Connection			
XX ⁽⁵⁾	Customer Specific		
Code	Electronic Type	Available for Certifications	
S	Direct load switching (2 wire) 20 to 264Vac 50/60Hz, 20 to 60 Vdc	NA, E1, E5, E6, E7, G5, G6	
B	PNP/PLC low voltage switching (3 wire) 20 to 60Vdc	NA, E1, E5, E6, E7, G5, G6	
R	Relay (SPDT/SPCO)	NA, E1, E5, E6, E7, G5, G6	
C ⁽⁶⁾	IS NAMUR (Ex ia)	I1, I3, I5, I6, I7	
Code	Surface Finish (Wetted Parts)	Available for Connections	
1	Standard surface finish	All	
2	Hand polished (Ra <0.8 µm)	Hygienic Connection Only	
Code	Product Certifications	Available for Electronic	Available for Housing
NA	No Hazardous Locations Certifications	S, B, R	A, D
G5 ⁽⁷⁾	FM Ordinary Locations (unclassified, safe area)	S, B, R	Y, T
G6 ⁽⁸⁾	CSA Ordinary Locations (unclassified, safe area)	S, B, R	Y, T
E1	ATEX Flameproof	S, B, R	X, S
E5 ⁽⁷⁾	FM Explosion Proof	S, B, R	Y, T
E6 ⁽⁸⁾	CSA Explosion Proof	S, B, R	Y, T
E7	IECEX Explosion Proof	S, B, R	X, S
I1	ATEX Intrinsic Safety	C	A, D
I3	NEPSI Intrinsic Safety	C	A, D
I5	FM Intrinsic Safety	C	A, D
I6	CSA Intrinsically Safe and Non-Incendive	C	A, D
I7	IECEX Intrinsic Safety	C	A, D
Code	Housing	Available for Certifications	
A	Glass Filled Nylon, M20 conduits/cable threads	NA, I1, I3, I5, I6, I7	
D	Glass Filled Nylon, 1/2-in. NPT conduits/cable threads	NA, I1, I3, I5, I6, I7	
X	Aluminum Alloy, M20 conduits/cable threads	E1, E7	
Y	Aluminum Alloy, 3/4-in. NPT conduits/cable threads	E5, E6, G5, G6	
S	Stainless Steel, M20 conduits/cable threads	E1, E7	
T	Stainless Steel 3/4-in. NPT conduits/cable threads	E5, E6, G5, G6	
Code	Fork Length	Available Connection	
A	Standard length 1.7-in. (44 mm)	All except flanged models	
H ⁽²⁾	Standard length flange 4.0-in. (102 mm)	All flanged models	
B ⁽²⁾	Ext 5.9-in. (150 mm)	All except Tri-clamp 5R and 2R	
C ⁽²⁾	Ext 11.8-in. (300 mm)	All except Tri-clamp 5R and 2R	
D ⁽²⁾	Ext 19.7-in. (500 mm)	All except Tri-clamp 5R and 2R	
L ⁽⁹⁾	Semi-ext 3.9-in. (98 mm)	1A, 1B, and 1D	
Specific Extended Fork Length			
E ⁽¹⁰⁾	Extended, Customer Specified Length in tenth of Inches	All except 1-in. BSPP o-ring seal 1P	
M ⁽¹⁰⁾	Extended, Customer Specified Length in Millimeters	All except 1-in. BSPP o-ring seal 1P	
xxxx ⁽¹⁰⁾	Specific customer specified length in inches or millimeters (only if fork length E or M is selected)		
Code	Options		
Calibration Data Certification			
Q4	Certificate of functional test		
Material Traceability Certification			
Q8 ⁽¹⁾⁽²⁾	Material Traceability Certification per EN 10204 3.1B		
Special Procedures			
P1 ⁽¹¹⁾	Hydrostatic Testing		

Product Data Sheet

00813-0100-4030, Rev DB
Catalog 2008 - 2009

Rosemount 2120



Overfill	
U1 ⁽¹²⁾	DIBt/WHG Overfill protection
Tag Plates	
ST	Tag plate SST engraved plate (maximum 16 digits)
WT	Tag plate laminated paper (maximum 40 digits)

Typical Model: 2120 D 0A C 1 I1 A A Q8 ST

- (1) Only available for wetted parts.
- (2) Not available for hand polished wet side.
- (3) Halar/PFA copolymer coating is not available on threaded options.
- (4) Only available of BSPT and NPT threaded process connection code 0A, 0D, 1A, and 1D as standard, other upon request.
- (5) Other process connections available upon request.
- (6) Rosemount 2120 IS Namur Vibrating Fork Level Sensor models 2120***C*I** has demonstrated proven reliability. It is manufactured and supported in a manner suitable for applications up to SIL 2 of IEC 61508 as a Type B Safety Related Subsystem when configured as a high level alarm in conjunction with a Namur Barrier.
- (7) See Product Certifications on page 8. E5 includes G5 requirements. G5 is for use in unclassified, safe area locations only.
- (8) See Product Certifications on page page Level-8. E6 includes G6 requirements. G6 is for use in unclassified, safe area locations only.
- (9) Only available with stainless steel material of construction D and glass nylon housing A and D.
- (10) Minimum length available for connection $\frac{3}{4}$ -in. threaded is 3.8-in. (95 mm), for 1-in. threaded is 3.7-in. (94 mm), for flanged is 3.5-in. (89 mm) and Tri-Clamp is 4.1-in. (105 mm). Maximum length up to 118.1-in. (3000 mm) except for Halar/PFA copolymer coating and hand polished process is 39.4-in. (1000 mm).

Example: Code E1181 is 118.1 inches.
Code M3000 is 3000 millimeters.
- (11) Option limited to units of no more than 59.1-in. (1500 mm) extended lengths.
Option not available for Halar/PFA coating.
- (12) Option not available for Stainless Steel housing code S and T.

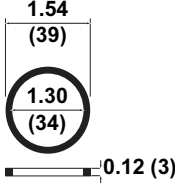
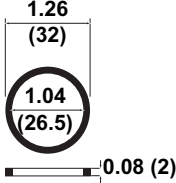
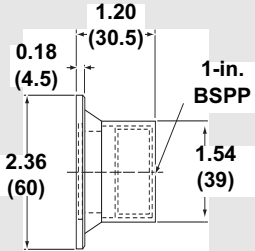
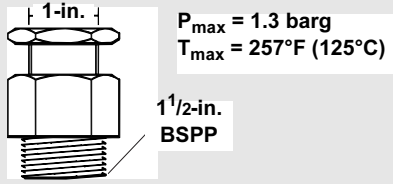
Spare Parts and Accessories

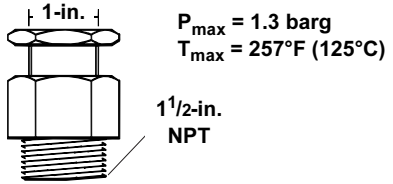
Part Number	Spares and Accessories	Part Number	Spares and Accessories
02100-1000-0001	Seal for 1-in. BSPP (G1A). Material: Non-asbestos BS7531 grade X carbon fiber with rubber binder 	02100-1040-0001	Seal for 3/4-in. BSPP (G3/4A) Material: Non-asbestos BS7531 grade X carbon fiber with rubber binder. 
02100-1010-0001	Hygienic adaptor boss 1-in. BSPP. Material: 316 SS fitting, FPM/FKM 'O' ring 	02120-2000-0001	Adjustable clamp gland for 1-in. extended lengths. Material: 316 St. steel, (Si) Silicone rubber seal 
02100-1020-0001	2-in. (51 mm) Tri-clamp kit including vessel fitting, clamp ring, seal. Material: 316 St. steel, NBR Nitrile 	02120-2000-0002	Adjustable clamp gland for 1-in. extended lengths. Material: 316 St. steel, (Si) Silicone rubber seal 
02100-1030-0001	Telescopic test magnet		
Replacement Cassettes		Available for Housing	
02120-3000-0001	Direct load switching (2 Wire) (Red)	A,D	
02120-3010-0001	PNP/PLC cassette (Yellow)	A,D	
02120-3020-0001	Intrinsically Safe cassette (Blue)	A,D	
02120-3030-0001	Relay output cassette (Green)	A,D	
02120-3040-0001	FM Direct load switching (2 Wire) (Red)	X, Y, S, T	
02120-3050-0001	FM PNP/PLC cassette (Yellow)	X, Y, S, T	
02120-3060-0001	FM Relay output cassette (Green)	X, Y, S, T	

NOTE:

I.S. cassettes can only be replaced with I.S. cassettes. Non-I.S. cassette types can be interchanged with other non-I.S. cassettes, but the new label must be fitted and the original part number transferred to the new label.

NOTES:

*Rosemount and the Rosemount logotype are registered trademarks of Rosemount Inc.
PlantWeb is a registered trademark of one of the Emerson Process Management group of companies.
HART is a registered trademark of the HART Communication Foundation.
Teflon, Viton, and Kalrez are registered trademarks of Du Pont Performance Elastomers.
FOUNDATION is a trademark of the Fieldbus Foundation.
DeltaV is a trademark of Emerson Process Management group of companies.
Hastelloy is a registered trademark of Haynes International.
Monel is a registered trademark of International Nickel Co.
All other marks are the property of their respective owners.*

Standard Terms and Conditions of Sale can be found at www.rosemount.com/terms_of_sale

Emerson Process Management

Rosemount Inc.

8200 Market Boulevard
Chanhassen, MN 55317 USA
T (U.S.) 1-800-999-9307
T (International) (952) 906-8888
F (952) 949-7001

www.rosemount.com



Emerson Process Management

Heath Place
Bognor Regis
West Sussex PO22 9SH
England
Tel 44 (1243) 863 121
Fax 44 (1243) 867 554

Emerson Process Management Asia Pacific Private Limited

1 Pandan Crescent
Singapore 128461
T (65) 6777 8211
F (65) 6777 0947/65 6777 0743
Enquiries@AP.EmersonProcess.com



EMERSON
Process Management